

DICOM Conformance Statement

CIARTIC Family VB10

Product Name

CIARTIC Move®



DICOM Conformance Statement Overview

CIARTIC Family is an Imaging Modality based on **FLUOROSPOT® Compact**. It supports Storage and Transfer of images utilizing the DICOM “Storage Service Class”, the display of data and retrieval of images from DICOM Archives utilizing the DICOM “Query/Retrieve Service Class”. Workflow Management is supported by querying worklists from RIS and returning information about the procedure performed. Furthermore, the import from and export to USB devices is supported.

CIARTIC Family conforms to the DICOM Standard and supports the network Services as described in Table 1: Network Services and the media Services as described in Table 2: Media Services

Table 1: Network Services

SOP Classes	SOP Class UID	User of Service (SCU)	Provider of Service (SCP)	
Verification				
Verification	1.2.840.10008.1.1	Yes	Yes	
SOP Classes	SOP Class UID	User of Service (SCU)	Provider of Service (SCP)	
		Send	Store	Display
SOP Classes created by CIARTIC Family				
Secondary Capture Image Storage (as Exam Protocol)	1.2.840.10008.5.1.4.1.1.7	Yes	Only for Query/Retrieve	Yes
X-Ray Angiographic Image Storage	1.2.840.10008.5.1.4.1.1.12.1	Yes	Only for Query/Retrieve	Yes
Multi-frame True Color Secondary Capture Image Storage	1.2.840.10008.5.1.4.1.1.7.4	Yes	Only for Query/Retrieve	No
X-Ray Radiation Dose SR Storage	1.2.840.10008.5.1.4.1.1.88.67	Yes	No	No
Enhanced CT Image Storage	1.2.840.10008.5.1.4.1.1.2.1	Yes	Only for Query/Retrieve	Yes
CT Image Storage	1.2.840.10008.5.1.4.1.1.2	Yes	Only for Query/Retrieve	Yes
SOP Classes managed by CIARTIC Family				
Digital X-Ray Image Storage- For Presentation	1.2.840.10008.5.1.4.1.1.1.1	No	Only for Query/Retrieve	Yes
Computed Radiography Image Storage	1.2.840.10008.5.1.4.1.1.1	No	Only for Query/Retrieve	Yes
Ultrasound Multi-frame Image Storage	1.2.840.10008.5.1.4.1.1.3.1	No	Only for Query/Retrieve	Yes
MR Image Storage	1.2.840.10008.5.1.4.1.1.4	No	Only for Query/Retrieve	Yes

SOP Classes	SOP Class UID	User of Service (SCU)	Provider of Service (SCP)	
Ultrasound Image Storage	1.2.840.10008.5.1.4.1.1.6.1	No	Only for Query/Retrieve	Yes
X-Ray Radiofluoroscopic Image Storage	1.2.840.10008.5.1.4.1.1.12.2	No	Only for Query/Retrieve	Yes
Storage Commitment				
Storage Commitment Push Model SOP Class	1.2.840.10008.1.20.1	Yes	No	
Worklist Management				
Modality Worklist Information Model - FIND	1.2.840.10008.5.1.4.31	Yes	No	
Modality Performed Procedure Step SOP Class	1.2.840.10008.3.1.2.3.3	Yes	No	
Query/Retrieve				
Study Root Q/R - Information Model - FIND	1.2.840.10008.5.1.4.1.2.2.1	Yes	No	
Study Root Q/R - Information Model - MOVE	1.2.840.10008.5.1.4.1.2.2.2	Yes	No	
Print Management				
Basic Grayscale Print Management Meta SOP Class	1.2.840.10008.5.1.1.9	Yes	No	
Presentation LUT SOP Class	1.2.840.10008.5.1.1.23	Yes (for Grayscale)	No	

Table 2: Media Services

Media Storage Application Profile	Write Files (FSC or FSU)	Read Files (FSR)
USB		
General purpose USB Media interchange with JPEG	Yes (see Note 1)	Yes

Note 1: with uncompressed setting

Table 3: Implementation Identifying Information

Name	Value
Application Context Name	1.2.840.10008.3.1.1.1

Implementation Class UID	1.3.12.2.1107.5.3.4
Implementation Version Name	"SIEMENS_FLC_80"

3	INTRODUCTION	8
3.1	Revision History	8
3.2	Audience	8
3.3	Remarks	8
3.4	Definitions, Terms and Abbreviations	9
3.5	References	9
4	NETWORKING	10
4.1	Implementation Model	10
4.1.1	Application Data Flow	10
4.1.2	Functional Definitions of Application Entities	12
4.1.3	Sequencing of Activities	14
4.2	AE Specifications	17
4.2.1	Verification AE Specification	17
4.2.2	Storage AE Specification	19
4.2.3	Storage Commitment AE Specification	24
4.2.4	Query/Retrieve AE Specification	26
4.2.5	Modality Worklist AE Specification	31
4.2.6	Modality Performed Procedure Step AE Specification	38
4.2.7	Print AE Specification	46
4.3	Network Interfaces	53
4.3.1	Physical Network Interface	53
4.3.2	Additional Protocols	53
4.3.3	IPv4 and IPv6 Support	53
4.4	Configuration	53
4.4.1	AE Title/Presentation Address Mapping	53
4.4.2	Parameters	56
5	MEDIA INTERCHANGE	57
5.1	Implementation Model	57
5.1.1	Application Data Flow Diagram	57
5.1.2	Functional definitions of AEs	57
5.1.3	Sequencing of Real World Activities	58
5.2	AE Specifications	58
5.2.1	Media Storage AE – Specification	58
5.2.2	Augmented Application Profiles	59
5.3	Media Configuration	59
6	SUPPORT OF EXTENDED CHARACTER SETS	60
7	ATTRIBUTE CONFIDENTIALITY PROFILES	61

7.1	Data Minimization	61
8	SECURITY	63
8.1	Security Profiles	63
9	ANNEXES	64
9.1	IOD Contents	64
9.1.1	Created SOP Instances	64
9.1.2	Image Type Values	99
9.1.3	Usage of Attributes from received IODs	99
9.1.4	Attribute mapping	99
9.1.5	Coerced / Modified fields	99
9.2	Data Dictionary of Private Attributes	100
9.3	Coded Terminology and Templates	105
9.3.1	Context Groups	105
9.3.2	Template Specifications	105
9.3.3	Private Code definitions	112
9.4	Grayscale Image Consistency	112
9.5	Standard Extended / Specialized / Private SOP Classes	112
9.5.1	Post Processing Module	113
9.5.2	Acquisition Data Module	113
9.5.3	Lab Settings Module	113
9.5.4	VDM Data Module	113
9.5.5	Raw Image Module	113
9.5.6	Navigation Data Module	113
9.6	Private Transfer Syntaxes	114
ANNEX A:	INDEX OF TABLES	115
ANNEX B:	TABLE OF FIGURES	117

3 Introduction

3.1 Revision History

Document Version	Date	Product	Product Version	Change
10046945-ESK-23S-00	05/2023	CIARTIC Family	VB10A	created
10046945-ESK-23S-01	03/2024	CIARTIC Family	VB10B	<ul style="list-style-type: none"> - Change of security profile, see chapter 8.1 Security Profiles. - Additional private attributes (0017,xx12), (0017,xx13) and (0017,xx51) added in Table 85. - Default display value for (0040,0002) and (0040,0003) added and deletion of (0040,3001) in Table 17. - Change of value for (0018,1160) in Table 68. - Removed value 'Round' for (0018,1147) in Table 69. - Clarification in Table 1, that Store SCP is only possible as part of the Query/Retrieve Workflow. Also chapter 4.1.1 was adapted accordingly. - Corrected the MPPS states: the system doesn't support the status 'DISCONTINUED.'

3.2 Audience

This document is intended for hospital staff, health system integrators, software designers or implementers. It is assumed that the reader has a working understanding of DICOM.

3.3 Remarks

The scope of this DICOM Conformance Statement is to facilitate integration between this product and other DICOM products. The Conformance Statement should be read and understood in conjunction with the DICOM Standard [1]. DICOM by itself does not guarantee interoperability.

The Conformance Statement does, however, facilitate a first-level comparison for interoperability between different applications supporting compatible DICOM functionality.

This Conformance Statement is not supposed to replace validation with other DICOM equipment to ensure proper exchange of intended information. In fact, the user should be aware of the following important issues:

- The comparison of conformance statements is the first step towards assessing interconnectivity and interoperability between CIARTIC Family and other DICOM conformant equipment.
- Test procedures should be defined and executed to validate the required level of interoperability with specific compatible DICOM equipment, as established by the healthcare facility.

Siemens Healthineers reserves the right to modify the design and specifications contained herein without prior notice. Please contact your local Siemens Healthineers representative for the most recent product information.

3.4 Definitions, Terms and Abbreviations

Definitions, terms, and abbreviations used in this document are defined within the different parts of the DICOM standard. Additional Abbreviations and terms are as follows:

AE	DICOM Application Entity
AET	Application Entity Title
ASCII	American Standard Code for Information Interchange
DICOM	Digital Imaging and Communications in Medicine
FSC	File Set Creator
FSR	File Set Reader
FSU	File Set Updater
GSDF	Grayscale Standard Display Function
IOD	DICOM Information Object Definition
ISO	International Standard Organization
n.a.	not applicable
NEMA	National Electrical Manufacturers Association
O	Optional Key Attribute
PDU	DICOM Protocol Data Unit
R	Required Key Attribute
SCU	DICOM Service Class User (DICOM client)
SCP	DICOM Service Class Provider (DICOM Server)
SOP	DICOM Service-Object Pair
SR	Structured Report
TFT	Thin Film Transistor (Display)
TID	Template ID
U	Unique Key Attribute
UID	Unique Identifier
UTF-8	Unicode Transformation Format-8
VR	Value Representation

3.5 References

- [1] NEMA PS3 / ISO 12052, Digital Imaging and Communications in Medicine (DICOM) Standard, National Electrical Manufacturers Association, Rosslyn, VA, USA (available free at <http://www.dicomstandard.org/>)
- [2] Integrating the Healthcare Enterprise – IHE Radiology Technical Framework – <http://www.ihe.net>

4 Networking

4.1 Implementation Model

CIARTIC Family supports storing DICOM images to remote nodes like workstations or Archiving Systems. Using the Storage Commitment Service, it can request safe keeping of previously stored instances from an Archiving system. Additionally, the CIARTIC Family can query remote nodes, retrieve and store selected instances from that node. Using the Modality Worklist Service, the CIARTIC Family can query a HIS/RIS for scheduled procedures. Performed Procedure Step status and other procedure data can be returned to the HIS/RIS using the Modality Performed Procedure Step (MPPS) Service. Furthermore, printing of color and grayscale images is supported.

4.1.1 Application Data Flow

The following figures provide a functional overview of the CIARTIC Family Application Entities (AE). Please do note that it is based on the default configuration and may differ depending on configuration at the customer site.

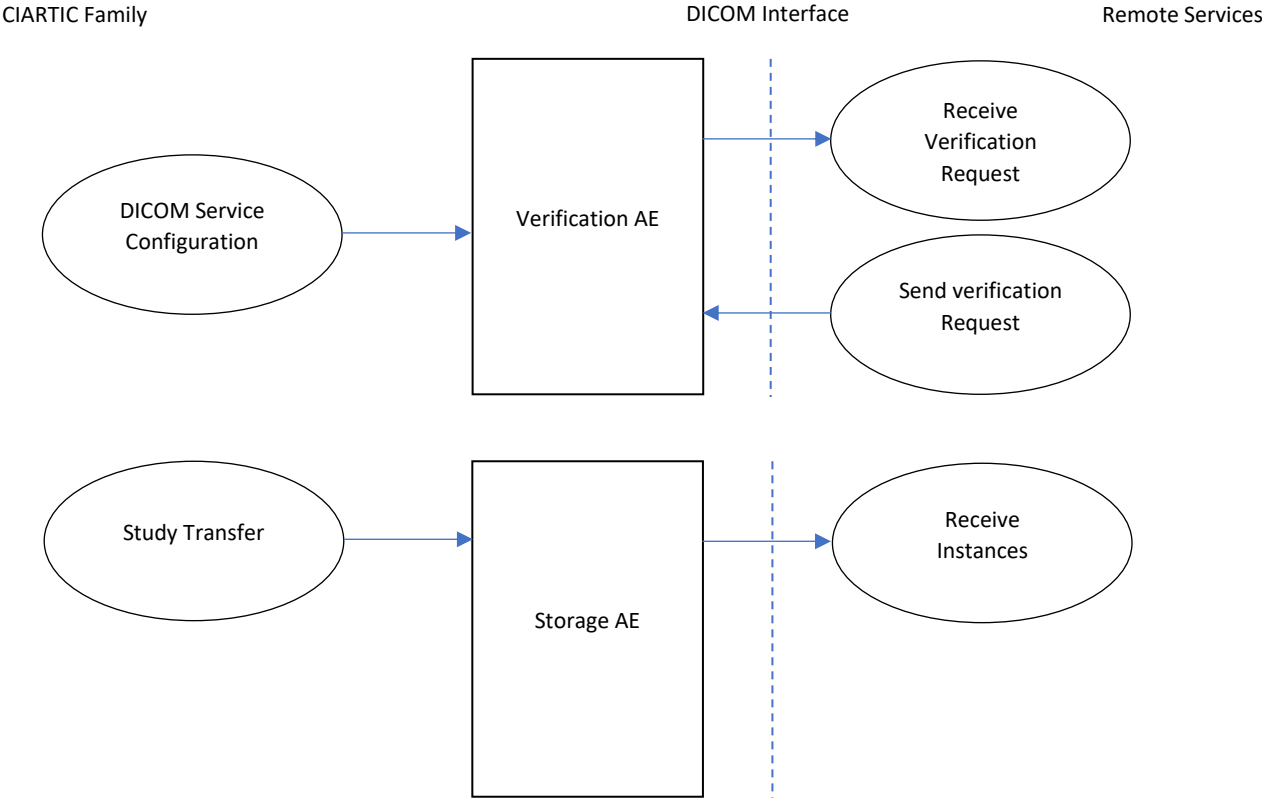

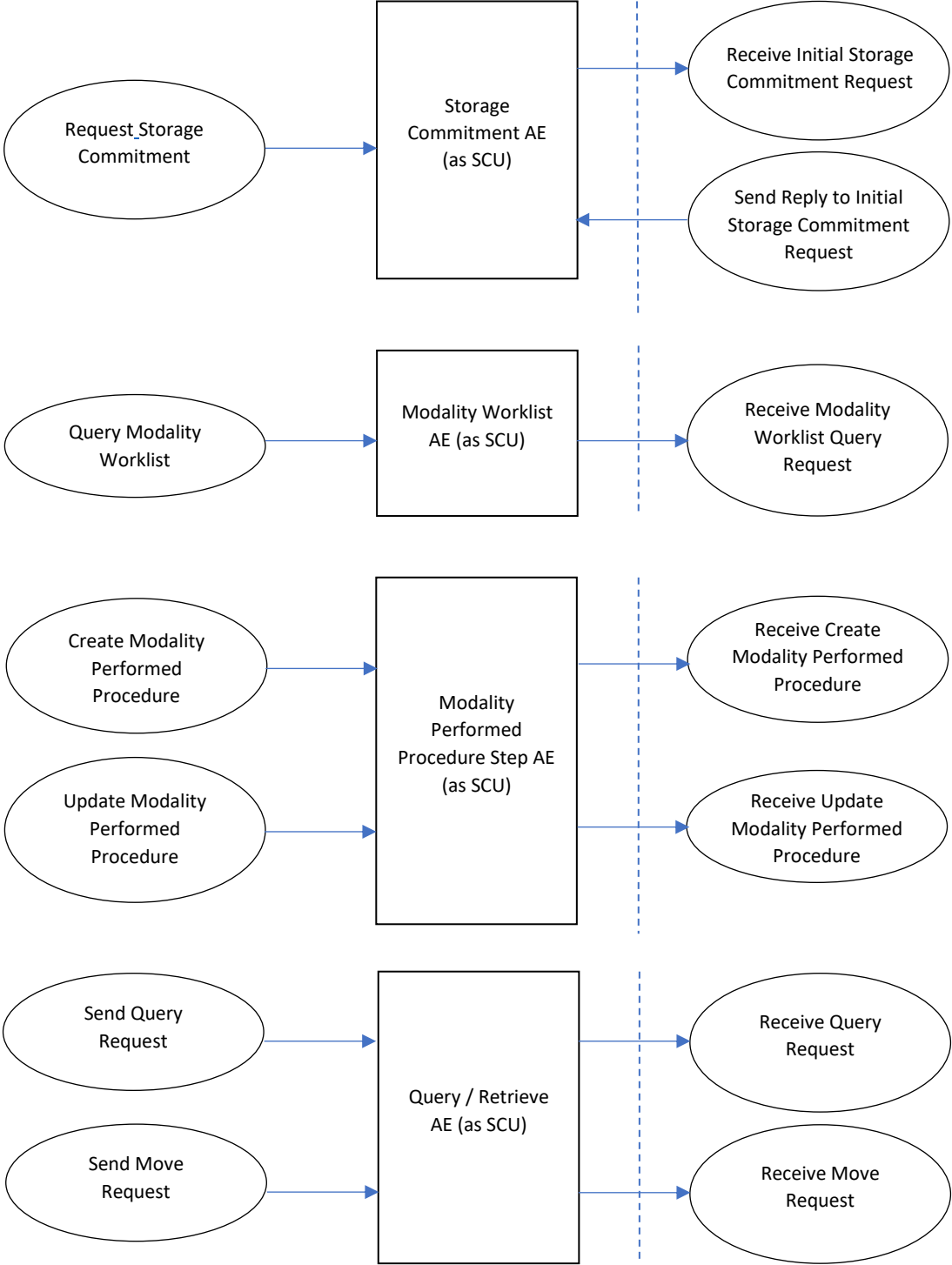

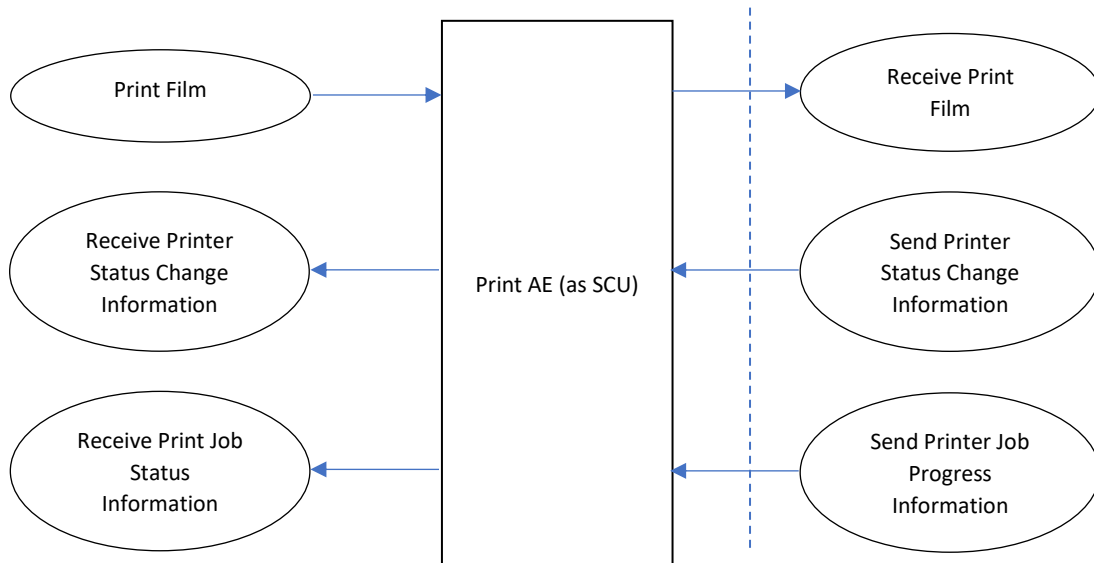

Figure 1: CIARTIC Family DICOM Data Flow diagram

- The CIARTIC Family DICOM Service Tool application opens an association when a "verification" of a remote application is requested during a configuration session. This can be done when entering new data to configure a remote application or to verify existing configuration data.
- The Storage SCU AE can send Composite SOP Instances and automatically request Storage Commitment for sent SOP Instances, if configured and handles incoming commitment status N-EVENT messages.
- The Query part of the Query/Retrieve SCU AE uses C-FIND to search a DICOM Database for Patient Study and Series information.
- The Retrieve part of the Query/Retrieve SCU AE uses C-MOVE to initiate a DICOM transfer of composite objects to the local database.
- The Print SCU sends film-sheets with n images to the printer. The printer status is monitored by sending Status requests.
- The Worklist SCU AE runs autonomously for cyclic "broad" query and issues C-FIND Worklist model requests. It can be manually triggered for most recent data. A "broad" query with user input can be triggered separately.
- The MPPS AE uses N-CREATE when first radiation exposure is released for a patient and updates via N-SET when closing the examination (triggers "final N-SET").

4.1.2 Functional Definitions of Application Entities

The SCP components of the Application Entities of the CIARTIC Family operate as background server processes. They exist as soon as the system is powered up and wait for association requests. Upon accepting an association with a negotiated Presentation Context they start to receive and process the requests described in the following sections.

The SCU components of the Application Entity are invoked upon requests from the user interface or indirect by trigger from internal processes.

4.1.2.1 Functional Definitions of Verification AE

The CIARTIC Family supports the Verification Service as SCP and SCU. As an SCU, Verification can be requested when entering new data for remote application configuration or to verify existing configuration data by sending a C-ECHO-RQ.

As an SCP of the Verification Service the CIARTIC Family processes and responds to incoming verification requests using the C-ECHO-RSP.

4.1.2.2 Functional Definition of Storage AE

The CIARTIC Family Storage SCU is invoked by the job control interface that is responsible for processing network archival tasks. The job consists of data describing the composite objects selected for Storage and the destination Application Entity Title. An association is negotiated with the destination Application Entity and the image data is transferred using the C-STORE-RQ. The transfer status is reported to the job control interface.

4.1.2.3 Functional Definition of the Storage Commitment AE

If configured, the CIARTIC Family can serve as an SCU for the DICOM Storage Commitment Service. Upon successful completion of a Storage SCU job, the system uses the N-ACTION-RQ to request Storage Commitment from a remote DICOM Storage Commitment SCP. The CIARTIC Family can handle incoming commitment status N-EVENT messages.

The commitment status derived from the related trigger response will be indicated in the related Status Flags of the related entity.

The Transaction UIDs of the pending commitment request are kept "open" (Job-status is "waiting") for a configurable time (default: 1h). If the "open time" for a pending commitment request has elapsed w/o a related response from the provider, the Transaction UID is removed and the related entities are indicated as "commit failed".

Open Transaction UIDs of pending commitment requests are discarded after a reboot of the system. The related entities are indicated as "commit failed".

4.1.2.4 Functional Definition of Query/Retrieve AE

The CIARTIC Family supports DICOM Query/Retrieve as an SCU: The user can initiate a query to a remote node using the C-FIND-RQ. After matching the specified keys, the remote Query/Retrieve SCP uses the C-FIND-RSP to return the results of its search, which will be displayed to the user. Depending on user action the CIARTIC Family Query/Retrieve DICOM SCU sends a C-MOVE-RQ to initiate a C-STORE sub-operation on the SCP to start an instance transfer from remote Storage SCU (running on Query/Retrieve SCP) to the system's Storage SCP.

The Storage SCP component of the CIARTIC Family DICOM application is operating as background server process. The process starts when the system is triggered to import images and waits then for Storage association requests. Upon accepting an association with a negotiated Presentation Context it starts to receive the Composite Image Objects and imports them to local database.

The CIARTIC Family supports the following query model:

- Study Root Query Model

4.1.2.5 Functional Definition of Modality Worklist AE

The CIARTIC Family Modality Worklist SCU issues DICOM Modality Worklist requests using C-FIND-RQs. All information retrieved will be held in the scheduling database for usage during Patient Registration procedure.

In case of a patient based Query entering specific matching criteria ("narrow query") is allowed. With the response data the Patient Registration dialog can be populated according to availability within the worklist response identifier.

4.1.2.6 Functional Definition of Modality Performed Procedure Step SCU AE

With the first radiation exposure for a registered Patient (i.e. a Scheduled Procedure Step from Worklist), the CIARTIC Family DICOM application will create a MPPS Instance and communicate it to the MPPS Manager (SCP). The status of MPPS is set to "Completed" when the patient is closed.

For unscheduled patients no MPPS message is sent.

4.1.2.7 Functional Definition of Print AE

The Print SCU is invoked by the user interface to setup film-sheet layout and whenever an image is ready to be printed on film. The Print SCU will hold and maintain all data needed to compile a complete film-sheet from the data (images, layout, configuration) received. Whenever a film-sheet is ready to print, the related data is used to supply the Information to the SOP Classes of the Print Management Service Class. A queue is maintained to intermediately store several film-sheets in case of

resource problems on printer. The SCU will only supply and require the mandatory SOP Classes of the Print Management Service Class.

4.1.3 Sequencing of Activities

This section describes the sequencing of the DICOM Communication Activities performed by the CIARTIC Family Entities using a UML sequence diagram. The Entities are depicted as vertical bars. The arrows show the messages exchanged.

4.1.3.1 System Configuration

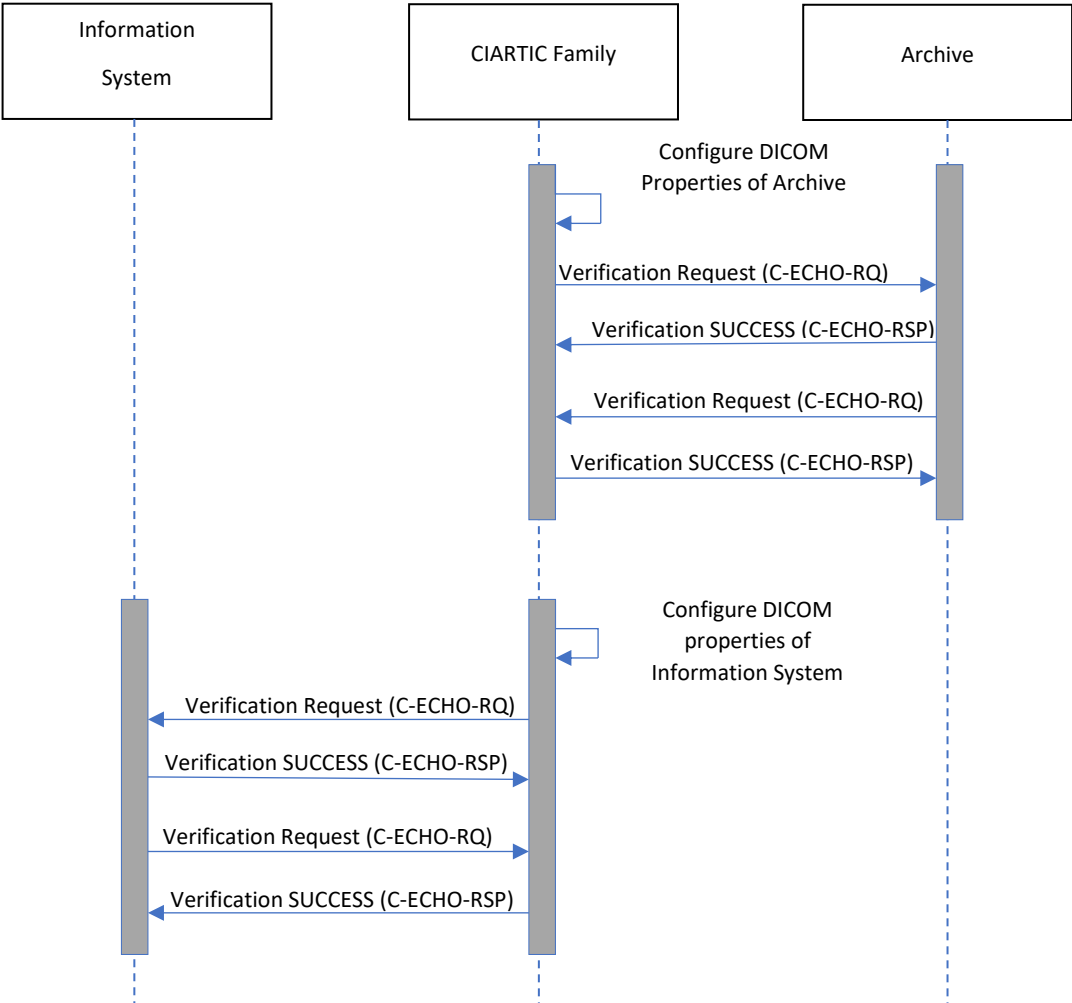

Figure 2: Sequence Diagram - System Configuration Workflow

4.1.3.2 Acquisition Workflow

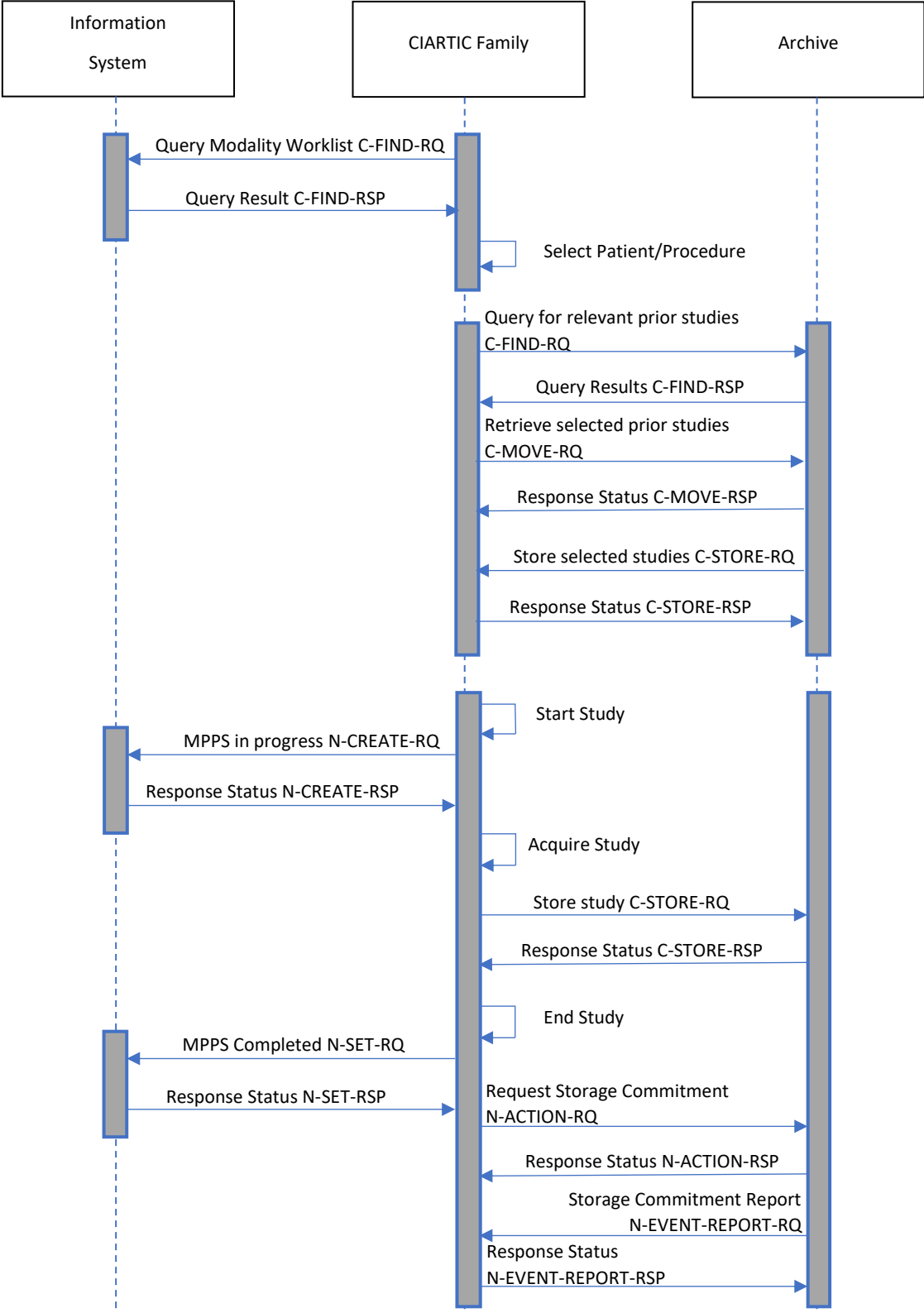

Figure 3: Sequence Diagram - Acquisition workflow

4.1.3.3 Printing Workflow

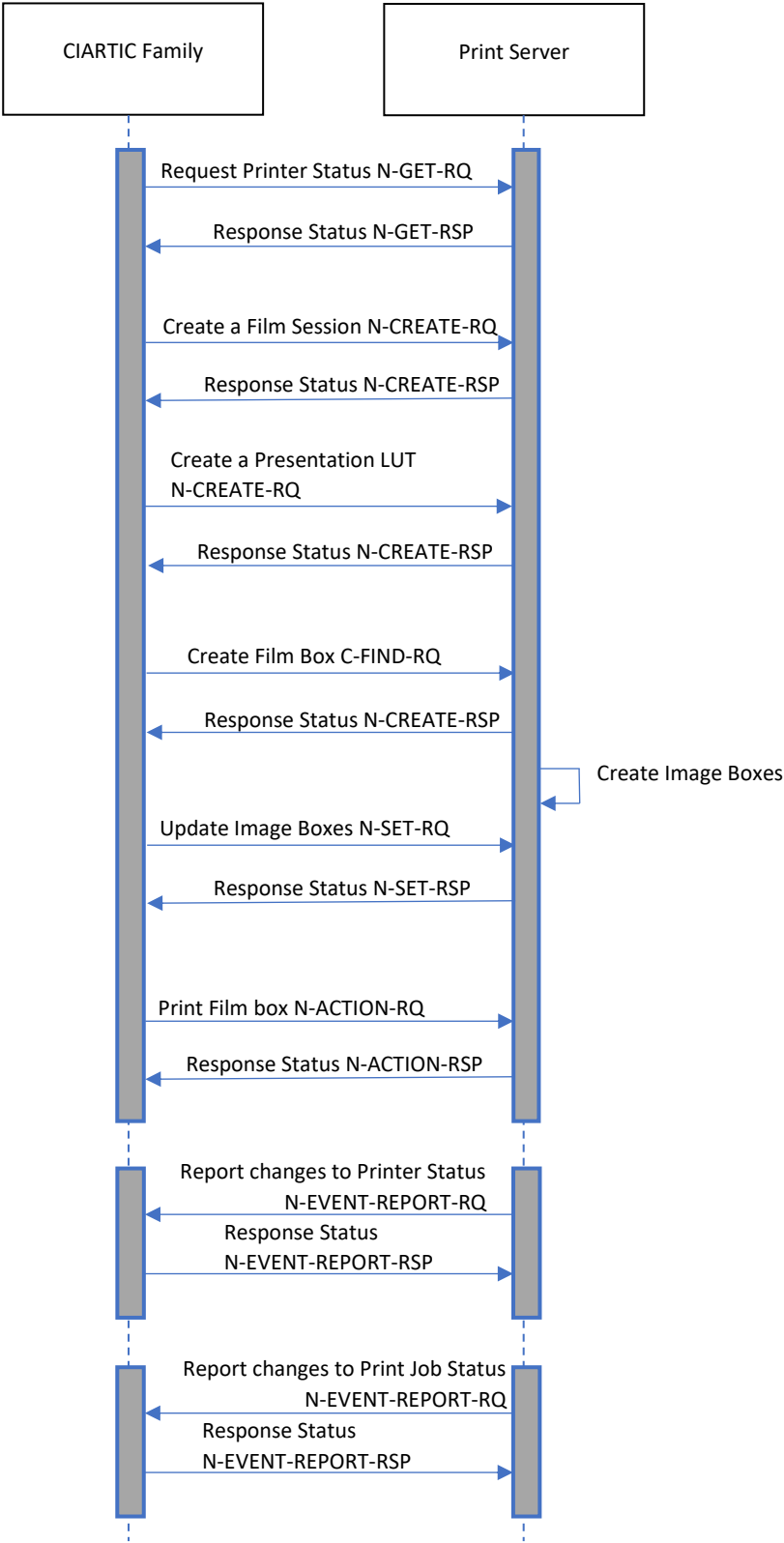

Figure 4: Printing

4.2 AE Specifications

This section outlines the specifications for each of the Application Entities that are part of the CIARTIC Family.

4.2.1 Verification AE Specification

4.2.1.1 SOP Classes

The Verification AE of the CIARTIC Family provides standard conformance to the Verification SOP Class listed in Table 1: Network Services section "Verification" in the "[Conformance Statement Overview](#)".

4.2.1.2 Association Policy

The CIARTIC Family DICOM Service Tool application attempts to open an Association for Verification Request whenever the Verification function is activated.

The CIARTIC Family DICOM Service Tool application initiates one association at a time to request verification.

4.2.1.2.1 Asynchronous Nature

The CIARTIC Family DICOM software does not support asynchronous communication (multiple outstanding transactions over a single association).

4.2.1.2.2 Implementation Identifying Information

For Implementation Identifying Information please refer to Table 3: Implementation Identifying Information in the "[Conformance Statement Overview](#)".

4.2.1.3 Association Initiation Policy

4.2.1.3.1 Activity “Send Verification Request”

4.2.1.3.1.1 Description and Sequencing of Activities

The CIARTIC Family serves as an SCU of the Verification Service Class. A C-ECHO-RQ is initiated by the Administrator Portal whenever “Verification” is requested. If an association to a remote Application Entity is successfully established, Verification with the configured AET is requested via the open association. If the C-ECHO-RSP from the remote Application contains a status other than “Success” this will be indicated to the user and the association is closed.

4.2.1.3.1.2 Proposed Presentation Contexts

Table 4: Presentation Context Table “Verification” below lists the supported presentation contexts for verification requests.

Table 4: Presentation Context Table “Verification”

Abstract Syntax		Transfer Syntax		Role	Extended Negotiation
Name	UID	Name List	UID List		
Verification	1.2.840.10008.1.1	Implicit VR Little Endian	1.2.840.10008.1.2	SCU	None
Verification	1.2.840.10008.1.1	Explicit VR Little Endian	1.2.840.10008.1.2.1	SCU	None
Verification	1.2.840.10008.1.1	Explicit VR Big Endian	1.2.840.10008.1.2.2	SCU	None

4.2.1.3.1.3 SOP specific Conformance for SOP classes

The ECHO-SCU provides standard conformance to the Verification Service Class.

4.2.1.4 Association Acceptance Policy

4.2.1.4.1 Activity “Receive Verification Request”

4.2.1.4.1.1 Description and Sequencing of Activities

The CIARTIC Family serves as an SCP of the Verification Service Class. The Verification SCP is part of the Storage SCP.

4.2.1.4.1.2 Accepted Presentation Contexts

The CIARTIC Family DICOM application will accept Presentation Contexts as shown in the following table:

Table 5: Presentation Context Table "Verification"

Abstract Syntax		Transfer Syntax		Role	Extended Negotiation
Name	UID	Name List	UID List		
Verification	1.2.840.10008.1.1	Implicit VR Little Endian	1.2.840.10008.1.2	SCP	None
Verification	1.2.840.10008.1.1	Explicit VR Little Endian	1.2.840.10008.1.2.1	SCP	None
Verification	1.2.840.10008.1.1	Explicit VR Big Endian	1.2.840.10008.1.2.2	SCP	None

4.2.1.4.1.3 SOP specific Conformance – Verification SCP

The ECHO-SCP provides standard conformance to the Verification Service Class.

4.2.2 Storage AE Specification

4.2.2.1 SOP Classes

The Storage AE provides Standard Conformance to the SOP Classes listed in "Table 1: Network Services" section "SOP Classes Created by the CIARTIC Family" and "SOP Classes Managed by the CIARTIC Family" in the "[Conformance Statement Overview](#)".

4.2.2.2 Association Policy

The DICOM Storage SCU application will be triggered by the transfer job queue. An association request is sent to the destination AE and, upon successful negotiation of a Presentation Context, the transfer is started. Depending on configuration, processing or resizing can be applied to the images prior to being sent.

The DICOM Storage SCP application will accept any number of storage SOP classes that are referred to above. There is no limit on the number of presentation contexts accepted except for the DICOM limit. In the event that the Siemens DICOM application runs out of resources, it will reject the association request.

CIARTIC Family will only accept Associations from known hosts with a known AET. Hosts and AETs have to be entered in "Local Service" by a Siemens Healthineers CSE.

The default PDU size used will be 64 KB.

The CIARTIC Family DICOM application initiates one association at a time.

4.2.2.2.1 Asynchronous Nature

The CIARTIC Family DICOM software does not support asynchronous communication (multiple outstanding transactions over a single association).

4.2.2.2.2 Implementation Identifying Information

For Implementation Identifying Information please refer to Note 1: with uncompressed setting

Table 3: Implementation Identifying Information“ in the [“Conformance Statement Overview“](#).

4.2.2.3 Association Initiation Policy

If a job with network destination gets active in the job list or a retrieve sub-operation is processed, the CIARTIC Family DICOM application attempts to initiate a new association for

- DIMSE C-STORE to send images and with successful status and
- N-ACTION DIMSE for the Storage Commitment Push Model Service Class to request commitment.

4.2.2.3.1 Activity “Send Instances”

4.2.2.3.1.1 Description and Sequencing of Activities

The C-STORE request is triggered by an export job with network destination. If the process successfully establishes an association to a remote Application Entity, it will transfer each image one after another via the open association. Processing features a nd resizing of the pixel matrix can be applied as part of the transfer. If the C-STORE Response from the remote Application contains a status other than "Success" or "Warning", the association is aborted.

With success status for the previous transfer, the CIARTIC Family Storage application sends, if storage Commitment is configured, the commit request (N-ACTION-RQ) message and waits for acceptance of this request (N-ACTION-RSP). After receiving this, the transaction is marked as "waiting".

The association will be closed after a configurable time (maximum of 10 seconds). After that receiving the storage commitment status is expected on a different association. If the commit response (N-EVENT-REPORT) does not arrive within the configured time-out, the transaction will be marked as failed.

4.2.2.3.1.2 *Proposed Presentation Contexts*

For all Image Objects listed in Table 1: Network Services in the Conformance Statement Overview the Transfer Syntaxes marked with “yes” in the Image Objects Column of the table below are supported.

For all Non-Image Objects listed in Table 1: Network Services in the Conformance Statement Overview the Transfer Syntaxes marked with “yes” in the Non-Image Objects Column of the table below are supported.

For a distinction between Image and Non-Image Objects please refer to the DICOM Standard PS3.3 Section A.1.4 “Overview of the Composite IOD Module Content [1]”.

Table 6: Proposed Presentation Contexts for Storage

UID value	Transfer Syntax	Image Objects	Non-Image Objects
1.2.840.10008.1.2	Implicit VR Little Endian	Yes	Yes
1.2.840.10008.1.2.1	Explicit VR Little Endian	Yes	Yes
1.2.840.10008.1.2.2	Explicit VR Big Endian	Yes	Yes

4.2.2.3.1.3 *SOP Specific Conformance for SOP Classes*

The CIARTIC Family can send images in different formats. In a user and destination specific service level configuration it can be configured whether images are sent original or resized.

For association and DIMSE level time-outs, please refer to section [Configuration](#) (4.4.2 Parameters) of this document.

Please refer to the related Image Object definition tables in the section [Annexes](#) (9.1.1 Created SOP Instances) for a list of all DICOM IOD attributes of type 2 and 3, which are encoded by the CIARTIC Family applications.

The DICOM images sent by CIARTIC Family DICOM application conform to the DICOM IOD definitions (Standard extended IODs). But they will contain additional private elements, which have to be discarded by a DICOM system when modifying the image.

The DICOM nodes are responsible for data consistency when modifying images. All unknown private attributes have to be removed upon modification!

Please refer to section [Annexes](#) (9.5 Standard Extended / Specialized / Private SOP Classes) for a list of possible private IOD attributes.

4.2.2.4 *Association Acceptance Policy*

4.2.2.4.1 *Activity “Receive Instances”*

4.2.2.4.1.1 *Description and Sequencing of Activities*

The CIARTIC Family DICOM application will accept an association and will receive SOP Instances according to the listed presentation contexts on that association and will store the images to the local hard disk if the conformance check is performed successfully.

Receiving is possible whenever an import request (C-MOVE) is sent to a remote destination. As long as it is active, the receiver process will accept an association and will receive images transmitted on that association and will store the images on disk in the own data base if the conformance check is performed successfully.

Upon successful receiving a C-STORE-RQ, the CIARTIC Family DICOM receiver performs a plausibility test on the received image and available system resources. If this test succeeds, it returns the Status SUCCESS, otherwise one of the following status codes is returned and the association is aborted.

Table 7: Status Codes "Save to local disk"

Service Status	Meaning	Error Codes (0000,0900)
Failure	Refused: This error indicates a lack of Resources (e.g. not enough disk space) on the CIARTIC Family modality.	A700
	Invalid Dataset: An error occurred while processing the image, which makes it impossible to proceed. The image will not be stored and the association is aborted.	A900 C000
Success	Successful	000

4.2.2.4.1.2 Accepted Presentation Contexts

For all Image Objects listed in Table 1: Network Services the Transfer Syntaxes marked with "yes" in the Image Objects Column of the table below are supported.

For all Non-Image Objects listed in Table 1: Network Services the Transfer Syntaxes marked with "yes" in the Non-Image Objects Column of the table below are supported.

For a distinction between Image and Non-Image Objects please refer to the DICOM Standard PS3.3 Section A.1.4 "Overview of the Composite IOD Module Content".

4.2.2.4.1.3 SOP-specific Conformance for Storage SOP classes

The CIARTIC Family conforms to the Full Storage Class at Level 1.

Any Explicit VR Transfer Syntax is preferred to be used by the Storage SCU when sending Composite Image Instances to the CIARTIC Family DICOM application.

The following sections will differentiate the attribute contents required for Image Viewing.

4.2.2.4.1.3.1 Image Pixel Attribute Acceptance Criterion for Grayscale Images

The CIARTIC Family Viewing application accepts pixel data with unsigned integer and 8 or 16 bits allocated.

Accepted values:

Pixel Plane

- Samples per Pixel (0028,0002) = 1
- Photometric Interpretation (0028,0004) = "MONOCHROME2" + "RGB"
- Only Pixel Aspect Ratio (0028.0034) 1:1 is supported
- Pixel Representation (attribute 0028,0103) = 0
- Bits Allocated (0028,0100) = 8, 16
- Bits Stored (0028,0101) = 8, 10, 12, 16
- High Bit (0028,0102) = 7, 9, 11, 15

Following restrictions are valid:

- For VOI LUT, only the linear LUT (Window Center/Width) and not the VOI LUT Sequence is supported.
- Display of overlay planes is not supported.
- No manipulations except windowing are allowed on imported images in 2D viewing.
- Multiframe objects with identical image type are expected to be separated in series level.

- 3D Viewing only supports Photometric Interpretation (0028,0004) = "MONOCHROME2" and Bits Stored (0028,0101) = 12 or 16.

Table 8 below list the status codes that the CIARTIC Family can return:

Table 8: Storage C-STORE-RSP Status

Service Status	Further Meaning	Error Code	Reason
Success	Success	0000	Image received correctly
Failure	Refused	A700	This error indicates a lack of Resources (e.g. not enough disk space) on the CIARTIC Family modality.
Failure	Invalid Dataset	C000, A900	An error occurred while processing the image, which makes it impossible to proceed. The image will not be stored and the association is aborted.

4.2.2.4.1.4 Other SOP specific behavior

n.a.

4.2.3 Storage Commitment AE Specification

4.2.3.1 SOP Classes

The Storage Commitment AE of the CIARTIC Family provides standard conformance to the SOP Class listed in "Table 1: Network Services" section "Storage Commitment" in the "Conformance Statement Overview" Association Policy

With a Send Job successfully completed, the DICOM application will generate the Storage Commitment Action Information (if configured) which references to all Instances of the processed job. The Commit Request is sent over a single opened association. The CIARTIC Family will wait for Status responses of the Storage Commitment Request. If the Provider accepts the Storage Commitment with Success Status, the generated Transaction UID, together with study identification data and a timestamp, is kept. Depending on configuration, the association is closed or kept open for a configured time range. If the association is closed immediately, the response is expected on a different association which is the default setting. Multiple Storage Commitment Requests can be pending.

The CIARTIC Family DICOM application initiates one association at a time.

The default PDU size used will be 64KB.

4.2.3.1.1 Asynchronous Nature

The CIARTIC Family DICOM software does not support asynchronous communication (multiple outstanding transactions over a single association).

4.2.3.1.2 Implementation Identifying Information

For Implementation Identifying Information please refer to Note 1: with uncompressed setting

Table 3: Implementation Identifying Information" in the "[Conformance Statement Overview](#)".

4.2.3.2 Association Initiation Policy

With a Send Job successfully completed, the DICOM application will generate the Storage Commitment Action Information (if configured) which references to all Instances of the processed job. The Commit Request is sent over a single opened association. The CIARTIC Family will wait for Status responses of the Storage Commitment Request. If the Provider accepts the Storage Commitment with Success Status, the generated Transaction UID, together with study identification data and a timestamp, is kept. Depending on configuration, the association is closed or kept open for a configured time range. If the association is closed immediately, the response is expected on a different association which is the default setting. Multiple Storage Commitment Requests can be pending.

4.2.3.2.1 Activity "Send Initial Storage Commitment Request"

4.2.3.2.1.1 Description and Sequencing of Activities

The CIARTIC Family serves as an SCU of the Storage Commitment Service Class. After successful transfer (C-STORE) of Imaging Objects to a configured Archive, the Storage Commitment SCU initiates an N-ACTION-RQ, if Storage Commitment is configured, and waits for acceptance of this request (N-ACTION-RSP). After receiving this, the transaction is marked as "waiting".

The association will be closed after a configurable time (maximum of 10 seconds). After that receiving the storage commitment status is expected on a different association. If the commit response (N-EVENT-REPORT) does not arrive within the configured time-out, the transaction will be marked as failed.

Storage Commitment is supported for all Storage SOP Classes listed in Table 1: Network Services. Sections SOP Classes created/managed by CIARTIC Family.

4.2.3.2.1.2 Proposed Presentation Contexts

The CIARTIC Family DICOM application supports the Presentation Contexts listed in the following table for the Storage Commitment Service Class.

Table 9: Proposed Presentation Contexts for Storage Commitment

Abstract Syntax		Transfer Syntax		Role	Ext. Neg.
Name	UID	Name List	UID List		
Storage Commitment Push Model	1.2.840.10008.1.20.1	Implicit VR Little Endian	1.2.840.10008.1.2	SCU	None
		Explicit VR Little Endian	1.2.840.10008.1.2.1		
		Explicit VR Big Endian	1.2.840.10008.1.2.2		

4.2.3.2.1.3 *SOP specific Conformance for SOP classes*

Storage Commitment is supported for all the SOP Classes detailed in Table 1: Network Services.

The Referenced Study Component Sequence is not supported.

Storage Media File-Set ID and UID Attributes will not be supported in the commitment request (N-ACTION primitive) invoked by the Storage Commitment SCU.

4.2.3.2.2 *Activity "Send Reply to Initial Storage Commitment Request"*

4.2.3.2.2.1 *Description and Sequencing of Activities*

After sending a Storage Commitment Request the CIARTIC Family either waits on the same association or, being configured to receive response on a separate association, closes the association and waits for an association request from the Storage Commitment SCP that wants to send the results.

Any incoming Notification will be checked for validity, that is, if the related Transaction UID is still part of the Pending Request Queue.

If the Notification is valid the related Instances are marked with the reported status. The over-all Commit Status of the higher Information Entities in the CIARTIC Family database is derived from propagation of the States of all sub-ordinate Image entities included in a study.

The Status Flags directly affected by Storage Commitment results and indicated in the different entities of the Patient previous list can be one of

- The flag chars S/s show, that all/some images are sent to a DICOM workstation and also committed, in case the DICOM destination is working with Storage Commitment.
- The flag chars A/a show that all/some images are sent to a DICOM workstation tagged as "Archive" and also committed, in case the "Archive" is working with Storage Commitment.

4.2.3.2.2.2 *SOP specific Conformance for SOP classes*

If the Commitment response (N-EVENT-REPORT) received has the status of "complete - failure exists", the transaction is marked as failed, else the transaction is marked as "completed". In both cases, a message is shown to the user.

The related status flags are set for the committed images in the local database.

The CIARTIC Family DICOM application will not support the Storage Media File Set ID attributes.

4.2.4 Query/Retrieve AE Specification

4.2.4.1 SOP Classes

The Query/Retrieve AE provides Standard Conformance to the SOP Classes listed in "Table 1: Network Services" section "Query/Retrieve" in the "[Conformance Statement Overview](#)".

4.2.4.2 Association Policy

With the "Query/Retrieve..." function the query data can be entered, and the DICOM Query/Retrieve application is initiated. A query request will be sent out to one remote node that can be selected from a list of configured Query Providers. The results compiled from the response data will be displayed to the user. Upon request (Import), the retrieval of selected items is initiated.

The default PDU size used will be 64KB.

The CIARTIC Family DICOM application initiates one association for each query request.

For Query it initiates a new association to the remote node and issues the C-FIND request to retrieve all the requested patient and study information matching the search criteria. For the Retrieve request (C-MOVE) only one association is initiated per destination.

4.2.4.2.1 Asynchronous Nature

The CIARTIC Family DICOM software does not support asynchronous communication (multiple outstanding transactions over a single association).

4.2.4.2.2 Implementation Identifying Information

For Implementation Identifying Information please refer to Note 1: with uncompressed setting

Table 3: Implementation Identifying Information in the "[Conformance Statement Overview](#)".

4.2.4.3 Association Initiation Policy

The CIARTIC Family DICOM application will request associations for the following DIMSE-C operations as SCU:

- C-FIND
- C-MOVE

Extended negotiation (relational query) is not supported for the above listed services

4.2.4.3.1 Activity “Send Query Request” for Instances

4.2.4.3.1.1 Description and Sequencing of Activities

The CIARTIC Family serves as an SCU for the following SOP Class

- Study Root Q/R Information Model – FIND SOP Class

The associated activity is to fill out a query form with search data and pass it as query to the network application which issues a C-FIND over a previously built association. The remote SCP will respond with related data-entries that will be passed to a browser application. If needed, further associations are opened for querying data from sub-subsequent entities. When data transfer is finished, each association is closed.

If the C-FIND Response from the remote Application contains an error status, the association is aborted.

4.2.4.3.1.2 Proposed Presentation Contexts

The CIARTIC Family will propose Presentation Contexts as shown in the following table:

Table 10: Proposed Presentation Contexts for Query

Abstract Syntax		Transfer Syntax		Role	Ext. Neg.
Name	UID	Name List	UID List		
Study Root Query/ Retrieve Information Model – FIND	1.2.840.10008.5.1.4.1.2.2.1	Implicit VR Little Endian	1.2.840.10008.1.2	SCU	none
		Explicit VR Little Endian	1.2.840.10008.1.2.1		
		Explicit VR Big Endian	1.2.840.10008.1.2.2		

4.2.4.3.1.3 SOP Specific Conformance Statement to Query SOP classes

The CIARTIC Family Search application supports a

- DIMSE C-CANCEL

If the user wishes to cancel a running Query request via the CIARTIC Family user interface ("Cancel" button while a "Search..." is active).

The CIARTIC Family checks for the following status codes in the Query SCP's C-FIND-RSP:

Table 11: DICOM Command Response Status Handling Behavior

Service Status	Further Meaning	Error Code	Related Fields
Refused	Out of Resources	A700	(0000,0902)
Failed	Identifier does not match SOP Class	A900	(0000,0901) (0000,0902)
	Unable to process	Cxxx	(0000,0901) (0000,0902)
Cancel	Matching terminated due to Cancel request	FE00	none
Success	Matching is complete - No final Identifier is supplied	000	none
Pending	Matches are continuing - Current Match is supplied and any Optional Keys were supported in the same manner as Required Keys	FF00	Identifier
	Matches are continuing - Warning that one or more Optional Keys were not supported for existence and/or matching for this identifier	FF01	Identifier

The CIARTIC Family DICOM Query/Retrieve SCU supports hierarchical queries with all mandatory search keys. The interactive querying of attributes on IMAGE level is not supported by the Query SCU; hence retrieval of individual images is not possible. The following table describes the search keys for the different query models that the SCU supports. Matching is either wildcard, which means that the user can supply a string containing wildcards, or universal, which means that the attribute is requested as return value.

Table 12: Attributes supported for Study/Series Query – SCU

Attribute Name	Tag	Type	User input	UI
Patient Level				
Patient's Name	(0010,0010)	R	enter value	yes
Patient ID	(0010,0020)	U / R	enter value	yes
Patient's Birth Date	(0010,0030)	O	enter value	yes
Patient's Sex	(0010,0040)	O	enter value	yes

Attribute Name	Tag	Type	User input	UI
Study Level				
Study Instance UID	(0020,000D)	U	--	yes
Study ID	(0020,0010)	R	enter value	yes
Study Date	(0008,0020)	R	--	yes
Study Time	(0008,0030)	R	--	yes
Accession Number	(0008,0050)	R	enter value	yes
Study Description	(0008,1030)	O	--	yes
Number of Study related Series	(0020,1206)	O	--	yes
Number of Study related Instances	(0020,1208)	O	--	yes
Series Level				
Series Instance UID	(0020,000E)	U	--	Yes
Series Number	(0020,0011)	R	--	Yes
Modality	(0008,0060)	R	--	Yes
Series Description	(0008,103E)	O	--	Yes
Body Part Examined	(0018,0015)	O	--	Ye
Number of Series related Instances	(0020,1209)	O	--	Yes

Legend:

- U – Unique Key Attribute
- R – Required Key Attribute
- O – Optional Key Attribute

4.2.4.3.2 Activity "Send Move Request"

4.2.4.3.2.1 Description and Sequencing of Activities

The CIARTIC Family serves as an SCU for the following SOP Class

- Study Root Q/R Information Model – MOVE SOP Class

When selecting a data entry in the Query UI and activating the "Import" function, a retrieval request is passed to the CIARTIC Family DICOM application which issues a C-MOVE service according to the Study Root query model. (The Storage Service Class Conformance Statement describes the C-STORE service, which is generated by processing the C-MOVE service.)

The received image data are processed as described in the Storage class SCP descriptions.

The CIARTIC Family DICOM application will always insert the own Storage SCP AE as "Move Destination.

4.2.4.3.2.2 Proposed Presentation Contexts

The CIARTIC Family proposes Presentation Contexts shown in the following table:

Table 13: Proposed Presentation Contexts for Retrieve and Activity “Send Move Request”

Abstract Syntax		Transfer Syntax		Role	Ext. Neg.
Name	UID	Name List	UID List		
Study Root Query/Retrieve Model – MOVE	1.2.840.10008.5.1.4.1.2.2.2	Implicit VR Little Endian	1.2.840.10008.1.2	SCU	None
		Explicit VR Little Endian	1.2.840.10008.1.2.1		
		Explicit VR Big Endian	1.2.840.10008.1.2.2		

4.2.4.3.2.3 SOP Specific Conformance Statement for Move SCU Classes

All required keys will be provided in the retrieve request identifier, as defined in DICOM Standard.

The behavior of CIARTIC Family when encountering status codes in a C-MOVE-RSP is summarized in Table 14

Table 14: DICOM Command Response Status Handling Behavior

Service Status	Further Meaning	Error Code	Related Fields
Refused	Out of Resources - Unable to calculate number of matches	A701	(0000,0902)
	Out of Resources - Unable to perform sub operations	A702	(0000,1020)
			(0000,1021) (0000,1022) (0000,1023)
Move Destination unknown	A801	n.a.	
Failed	Identifier does not match SOP Class	A900	(0000,0901) (0000,0902)
	Unable to process	Cxxx	(0000,0901) (0000,0902)
Cancel	Sub-operations terminated due to Cancel Indication	FE00	(0000,1020) (0000,1021) (0000,1022) (0000,1023)
Warning	Sub-operations Complete - One or more Failures of Warnings	B000	(0000,1020) (0000,1021) (0000,1022) (0000,1023)
Pending	Sub-operations are continuing	FF00	(0000,1020) (0000,1021) (0000,1022)

			(0000,1023)
Success	Sub-operations Complete - No Failures or Warning	0000	(0000,1020) (0000,1021) (0000,1022) (0000,1023)

4.2.4.4 Association Acceptance Policy

n.a.

4.2.5 Modality Worklist AE Specification

4.2.5.1 SOP Classes

The Modality Worklist AE provides Standard Conformance to the SOP Classes listed in “Table 1: Network Services”, section “Worklist Management (Modality Worklist Information Model – FIND)” in the [“Conformance Statement Overview”](#).

4.2.5.2 Association Policy

It is possible to configure a cyclic update of the modality Worklist through a background worklist request with date/time and modality information.

In addition, the user can request worklist update with "Update Worklist". No duplicate entries will be added in the Worklist. Entries are uniquely identified by the Study Instance UID (0020,000D) for the Requested Procedure. An interactive worklist query can be issued with search criteria entered in the patient based Query dialog from the patient mode.

The default PDU size used will be 64KB.

The CIARTIC Family DICOM application initiates one association at a time to query worklist entry data.

4.2.5.2.1 Asynchronous Nature

The CIARTIC Family DICOM software does not support asynchronous communication (multiple outstanding transactions over a single association).

4.2.5.2.2 Implementation Identifying Information

For Implementation Identifying Information please refer to “Note 1: with uncompressed setting

Table 3: Implementation Identifying Information” in the [“Conformance Statement Overview”](#).

4.2.5.3 Association Initiation Policy

The CIARTIC Family DICOM application will cyclically query the worklist provider and by request from the patient registration interface. It establishes an association by using the

- C-FIND with Worklist information model

It is possible to configure multiple worklist providers but only one can be active at a time. The active worklist provider can be selected in the service.

4.2.5.3.1 Activity “Send Modality Worklist Query Request”

4.2.5.3.1.1 Description and Sequencing of Activities

A network application will perform worklist queries with the C-FIND request at regular intervals. In addition, it can be triggered by immediate request. All worklist data from previous queries will be deleted when new data is received.

No automatic clean-up of the Worklist is performed after a Patient-based Query since the worklist received - due to restricted search criteria - does not correspond to the list of all currently scheduled procedures for the modality.

4.2.5.3.1.2 Proposed Presentation Contexts

The CIARTIC Family will propose Presentation Contexts as shown in the following table:

Table 15: Proposed Presentation Contexts for Worklist

Abstract Syntax		Transfer Syntax		Role	Ext. Neg.
Name	UID	Name List	UID List		
Modality Worklist- FIND	1.2.840.10008.5.1.4.31	Implicit VR Little Endian	1.2.840.10008.1.2	SCU	None
		Explicit VR Little Endian	1.2.840.10008.1.2.1		
		Explicit VR Big Endian	1.2.840.10008.1.2.2		

4.2.5.3.1.3 SOP Specific Conformance for SOP Classes

Search Key Attributes of the Worklist C-FIND

The CIARTIC Family Modality Worklist SCU supports “broad worklist queries” with all required search keys. The following tables describe the “broad query” search keys that the SCU supports.

Table 16: Broad Query search keys

Attribute Name	Tag	Matching Key Type	Query Value
Scheduled Procedure Step			
Scheduled Procedure Step Sequence	(0040,0100)	R	
>Modality (It depends on service settings whether the "own Modality" is provided or not)	(0008,0060)	R	<zero length> or <own Modality>

Attribute Name	Tag	Matching Key Type	Query Value
>Scheduled Station AE Title (It depends on service settings whether the "own AET" is provided or not)	(0040,0001)	R	<own AET> or <zero length>
>Scheduled Procedure Step Start Date (It depends on service settings whether the actual Date with a full time range or an interactive input dialog for date/time specification is used.)	(0040,0002)	R	<act. Date>-<act. Date> or range from UI
>Schedule Procedure Step Start Time (It depends on service settings whether the actual Date with a full time range or an interactive input dialog for date/time specification is used.)	(0040,0003)	R	00.00-235959.00 or range from UI

R = Required

Return Key Attributes of the Modality Worklist C-FIND

The CIARTIC Family Modality Worklist SCU supports worklist queries with return key attributes of all types. The following tables describe the return keys that the SCU supports.

An "yes" in the UI column will indicate that the attribute is displayed in the user interface. The display is influenced by the related configuration.

All return values are visible by selecting the patient and pressing right mouse button.

Table 17: Modality Worklist C-Find Return keys

Attribute Name	Tag	Return Key Type	UI	Notes
SOP Common				
Specific Character Set	(0008,0005)	1C	No	
Scheduled Procedure Step				
Scheduled Procedure Step Sequence	(0040,0100)	1	No	
>Modality	(0008,0060)	1	No	
>Scheduled Station AE Title	(0040,0001)	1	No	
>Scheduled Procedure Step Start Date	(0040,0002)	1	No	If only (0040,0003) is given, the displayed value for (0040,0002) will be 1st of January 1900.
>Scheduled Procedure Step Start Time	(0040,0003)	1	No	If only (0040,0002) is given, the displayed value for (0040,0003) will be 00:00:00.
>Scheduled Performing Physician's Name	(0040,0006)	1	Yes	"Scheduled Performing Physician's Name (0040,0006)" is not directly included in the header. However, its value is stored in the header as

Attribute Name	Tag	Return Key Type	UI	Notes
				"Performing Physician's Name (0008,1050)". It can be modified by user during Patient Registration.
>Scheduled Procedure Step Description	(0040,0007)	1C	No	
>Scheduled Protocol Code Sequence	(0040,0008)	1C	No	
>>Code Value	(0008,0100)	1C	No	
>>Coding Scheme Designator	(0008,0102)	1C	No	
>>Coding Scheme Version	(0008,0103)	3	No	
>>Code Meaning	(0008,0104)	3	No	
>Scheduled Procedure Step ID	(0040,0009)	1	Yes	
>Scheduled Procedure Step Location	(0040,0011)	2	No	
>Pre-Medication	(0040,0012)	3	No	
>Scheduled Procedure Step Status	(0040,0020)	3	No	
>Requested Contrast Agent	(0032,1070)	3	No	
Requested Procedure				
Referenced Study Sequence	(0008,1110)	2	No	
>Referenced SOP Class UID	(0008,1150)	1C	No	
>Referenced SOP Instance UID	(0008,1155)	1C	No	
Study Instance UID	(0020,000D)	1	No	
Requested Procedure Description	(0032,1060)	1C	Yes	"Requested Procedure Description" (0032,1060) is not directly included in the header. However, its value is stored in the header as "Study Description" (0008,1030). It can be modified by user during Patient Registration.
Requested Procedure Code Sequence	(0032,1064)	1C	No	"Requested Procedure Code Sequence" (0032,1064) is not directly included in the header. However, its value is stored in the header as "Procedure Code Sequence" (0008,1032). It is not sent, when the scheduled protocol codes differ from the performed protocol codes.
>Code Value	(0008,0100)	1C	No	
>Coding Scheme Designator	(0008,0102)	1C	No	
>Coding Scheme Version	(0008,0103)	3	No	
>Code Meaning	(0008,0104)	3	No	
Requested Procedure ID	(0040,1001)	1	Yes	"Requested Procedure ID" (0040,1001) is directly included in the header in the requested attribute sequence. Additionally, its value is stored in the

Attribute Name	Tag	Return Key Type	UI	Notes
				header as "Study ID" (0020,0010). "Study ID" can be modified by the user during Patient Registration.
Requested Procedure Priority	(0040,1003)	2	Yes	
Names of intended Recipients of Results	(0040,1010)	3	No	
Requested Procedure Comments	(0040,1400)	3	No	
Imaging Service Request				
Accession Number	(0008,0050)	2	Yes	
Referring Physician's Name	(0008,0090)	2	Yes	
Requesting Physician	(0032,1032)	2	Yes	
Requesting Service	(0032,1033)	3	No	
Imaging Service Request Comments	(0040,2400)	3	No	
Visit Identification				
Admission ID	(0038,0010)	2	No	
Institution Name	(0008,0080)	3	Yes	
Institution Address	(0008,0081)	3	No	
Visit Status				
Current Patient Location	(0038,0300)	2	No	
Visit Admission				
Admitting Diagnosis Description	(0008,1080)	3	No	
Visit Relationship				
Referenced Patient Sequence	(0008,1120)		Yes	
>Referenced SOP Class UID	(0008,1150)		Yes	
>Referenced SOP Instance UID	(0008,1155)		Yes	
Patient Identification				
Patient's Name	(0010,0010)	1	Yes	
Patient ID	(0010,0020)	1	Yes	
Other Patient Names	(0010,1001)	3	No	
Patient Demographic				
Patient's Birth Date	(0010,0030)	2	Yes	If a date of birth (0010,0030) with zero length value is received via worklist, the date of birth will internally set to 1850/01/01. The value 1850/01/01 for the date of birth is not used in a DICOM header (DICOM Send, MPPS, USB Export), but again replaced by zero length.
Patient's Sex	(0010,0040)	2	Yes	

Attribute Name	Tag	Return Key Type	UI	Notes
Patient's Size	(0010,1020)	3	Yes	
Patient's Weight	(0010,1030)	2	Yes	
Patient's Address	(0010,1040)	3	No	
Military Rank	(0010,1080)	3	Yes	
Ethnic Group	(0010,2160)	3	No	
Patient Comments	(0010,4000)	3	No	
Patient Medical				
Medical Alerts	(0010,2000)	2	No	
Allergies	(0010,2110)	2	No	
Pregnancy Status	(0010,21C0)	2	No	
Smoking Status	(0010,21A0)	3	No	
Last Menstrual Date	(0010,21D0)	3	No	
Additional Patient History	(0010,21B0)	3	No	
Special Needs	(0038,0050)	2	No	
Patient State	(0038,0500)	3	No	

The default Query Configuration is set to "Modality" and "Date". Optionally, matching for the own "AE Title" and "Date" is configurable. For "Date" one of the following settings could be configured: "Today", "Yesterday – Today", "Today +/- 12 hours", "Today +/- 24 hours", and "Use no Date".

In Patient based worklist update, the usage of date and time can be deactivated! The Scheduled AE Title is used as Return Key only.

The behavior of the CIARTIC Family when encountering status codes in a C-FIND-RSP is summarized in Table 18.

Table 18: DICOM Command Response Status Handling Behavior

Service Status	Further Meaning	Error Code	Related Fields
Refused	Out of Resources	A700	(0000,0902)
Failed	Identifier does not match SOP Class	A900	(0000,0901) (0000,0902)
	Unable to process	Cxxx	(0000,0901) (0000,0902)
Cancel	Matching terminated due to Cancel request	FE00	none

Pending	Matches are continuing - Current Match is supplied and any Optional Keys were supported in the same manner as Required Keys	FF00	Identifier
	Matches are continuing - Warning that one or more Optional Keys were not supported for existence and/or matching for this identifier	FF01	Identifier
Success	Matching is complete - No final Identifier is supplied	0000	none

4.2.5.3.2 Activity "Get Worklist"

4.2.5.3.2.1 Description and Sequencing of Activities

With "Get Worklist" in the patient based Worklist Query dialog, the entered attributes are used to form a worklist request identifier. The response data is used to fill the Patient Registration dialog. The response data and only the response data is placed in the Worklist.

4.2.5.3.2.2 Proposed Presentation Contexts

This Activity will propose the same Presentation Context as with "Send Modality Worklist Query Request". Please see related table in section 4.2.5.3.1.2.

4.2.5.3.2.3 SOP Specific Conformance for SOP Classes

The CIARTIC Family DICOM worklist SCU supports "narrow worklist queries" with all required search keys. The following tables describe the "narrow query" search keys that the SCU supports.

Table 19: Patient based "narrow query" Search Keys

Attribute Name	Tag	Matching Key Type	Query Value
Scheduled Procedure Step			
Scheduled Procedure Step Sequence	(0040,0100)	R	
>Modality	(0008,0060)	R	Input from UI or <zero length>
>Scheduled Performing Physician's Name	(0040,0006)	R	Input from UI or <zero length>
Requested Procedure			
Requested Procedure ID	(0040,1001)	R	Input from UI or <zero length>
Imaging Service Request			
Accession Number	(0008,0050)	R	Input from UI or <zero length>
Referring Physician's Name	(0008,0090)	R	Input from UI or <zero length>
Patient Identification			
Patient's Name	(0010,0010)	R	Input from UI or <zero length>
Patient ID	(0010,0020)	R	Input from UI or <zero length>

R = Required

The Return Key Attribute handling and supported Status Codes are identical to the "Send Modality Worklist Query Request" activity. Please see [4.2.5.3.1](#) for details.

4.2.5.4 Association Acceptance Policy

The CIARTIC Family does not provide the functionality of an SCP of the Modality Worklist – Find SOP Class.

4.2.6 Modality Performed Procedure Step AE Specification

4.2.6.1 SOP Classes

The Modality Performed Procedure Step AE provides Standard Conformance to the SOP Classes listed in "Table 1: Network Services" section "Worklist Management (Modality Performed Procedure Step SOP Class)" in the "[Conformance Statement Overview](#)".

4.2.6.2 Association Policy

The creation of MPPS Instance is done automatically by CIARTIC Family whenever the first dose is applied to a non-emergency patient.

The default PDU size used will be 64KB.

The CIARTIC Family DICOM application initiates one association at a time to create or set the MPPS instance.

4.2.6.2.1 Asynchronous Nature

The CIARTIC Family DICOM software does not support asynchronous communication (multiple outstanding transactions over a single association).

4.2.6.2.2 Implementation Identifying Information

For Implementation Identifying Information please refer to "Note 1: with uncompressed setting

Table 3: Implementation Identifying Information" in the "[Conformance Statement Overview](#)".

4.2.6.3 Association Initiation Policy

The CIARTIC Family DICOM application will notify a RIS (MPPS Manager) about the status of a procedure while it is performed. It establishes an association by using the

- N-CREATE DIMSE according to the CREATE Modality Performed Procedure Step SOP Instance operation or a
- N-SET DIMSE to update the contents and state of the MPPS according to the SET Modality Performed Procedure Step Information operation.

It is possible to configure multiple MPPS providers but only one can be active at a time. The active MPPS provider can be configured via Service-UI.

4.2.6.3.1 Activity "Create Modality Performed Procedure Step"

4.2.6.3.1.1 Description and Sequencing of Activities

The CIARTIC Family serves as an SCU of the Modality Performed Procedure Step SOP Class.

A patient is registered by the Patient Registration "Exam" action. From this event the trigger to create a MPPS Instance is derived. The related Instance is then communicated to the configured RIS system when the first radiation is exposed. An association is established and the MPPS Instance is sent.

4.2.6.3.1.2 Accepted Presentation Contexts

The CIARTIC Family proposes Presentation Contexts as shown in the following table:

Table 20: Acceptable Presentation Contexts Activity “Create MPPS”

Abstract Syntax		Transfer Syntax		Role	Ext. Neg.
Name	UID	Name List	UID List		
Modality Performed Procedure Step	1.2.840.10008.3.1.2.3.3	Implicit VR Little Endian	1.2.840.10008.1.2	SCU	None
		Explicit VR Little Endian	1.2.840.10008.1.2.1		
		Explicit VR Big Endian	1.2.840.10008.1.2.2		

4.2.6.3.1.3 SOP specific Conformance for MPPS SOP class

The Performed Procedure Step SCU interprets following N-CREATE status codes as Warning or Success:

Table 21: MPPS N-CREATE-RSP Status Handling Behavior

Service Status	Further Meaning	Error Code
Warning	Attribute List Error.	0107
	Attribute Value out of Range	0116
Success	MPPS Instance created.	0000

The Siemens CIARTIC Family DICOM Modality Performed Procedure Step SCU informs the remote SCP when the examination of a scheduled procedure step is performed. The N-CREATE message is sent when the first radiation was exposed for a registered patient. The following table describes the supported attributes of a N-CREATE message:

Table 22: Attributes supported in MPPS N-CREATE-RQ

Attribute	Tag	Source	Value	Presence	Comments
Specific Character Set	(0008,0005)	MWL/AUTO	from MWL or created	ANAP	
Performed Procedure Step Relationship					
Scheduled Step Attributes Sequence	(0040,0270)		n.a.	ALWAYS	
>Study Instance UID	(0020,000D)	MWL	from MWL	ALWAYS	
>Referenced Study Sequence	(0008,1110)	MWL/AUTO	from MWL or <zero length>	VNAP	

Attribute	Tag	Source	Value	Presence	Comments
>>Referenced SOP Class UID	(0008,1150)	MWL	from MWL	ANAP	
>>Referenced SOP Instance UID	(0008,1155)	MWL	from MWL	ANAP	
>Accession Number	(0008,0050)	MWL/USER	from MWL or user input	VNAP	
>Requested Procedure ID	(0040,1001)	MWL/USER	from MWL or user input	VNAP	
>Requested Procedure Description	(0032,1060)	MWL	from MWL or <zero length>	VNAP	
>Scheduled Procedure Step ID	(0040,0009)	MWL	from MWL or <zero length>	VNAP	
>Scheduled Procedure Step Description	(0040,0007)	MWL	from MWL or <zero length>	VNAP	
>Scheduled Protocol Code Sequence	(0040,0008)	MWL	from MWL or <zero length>	VNAP	
>>Code Value	(0008,0100)	MWL	from MWL	ANAP	
>>Coding Scheme Designator	(0008,0102)	MWL	from MWL	ANAP	
>>Coding Scheme Version	(0008,0103)	MWL	from MWL	ANAP	
>>Code Meaning	(0008,0104)	MWL	from MWL	ANAP	
Patient's Name	(0010,0010)	MWL/USER	from MWL or user input	ALWAYS	
Patient ID	(0010,0020)	MWL/USER	from MWL or user input	ALWAYS	
Patient's Birth Date	(0010,0030)	MWL/USER	from MWL or user input	VNAP	
Patient's Sex	(0010,0040)	MWL/USER	from MWL or user input	ALWAYS	
Patient's Address	(0010,1040)	MWL	from MWL, only if available	ANAP	
Additional Patient History	(0010,21B0)	MWL	from MWL	ANAP	
Referenced Patient Sequence	(0008,1120)	MWL	from MWL or <zero length>	VNAP	
>Referenced SOP Class UID	(0008,1150)	MWL	from MWL	ANAP	
>Referenced SOP Instance UID	(0008,1155)	MWL	from MWL	ANAP	
Performed Procedure Step Information					
Performed Station AE Title	(0040,0241)	CONFIG	Local AE Title	ALWAYS	

Attribute	Tag	Source	Value	Presence	Comments
Performed Station Name	(0040,0242)	CONFIG	Own hostname	VNAP	
Performed Location	(0040,0243)	AUTO	<zero length>	EMPTY	
Performed Procedure Step Start Date	(0040,0244)	AUTO	created	ALWAYS	
Performed Procedure Step Start Time	(0040,0245)	AUTO	created	ALWAYS	
Performed Procedure Step End Date	(0040,0250)	AUTO	<zero length>	EMPTY	
Performed Procedure Step End Time	(0040,0251)	AUTO	<zero length>	EMPTY	
Performed Procedure Step Status	(0040,0252)	AUTO	"IN PROGRESS"	ALWAYS	
Performed Procedure Step ID	(0040,0253)	MWL/AUTO	From SPS ID or created	ALWAYS	
Performed Procedure Step Description	(0040,0254)	MWL	from SPS Description or <zero length>	VNAP	
Performed Procedure Type Description	(0040,0255)	AUTO	<zero length>	EMPTY	
Procedure Code Sequence	(0008,1032)	MWL	<zero length>	EMPTY	
Performed Procedure Step Discontinuation Reason Code Sequence	(0040,0281)	AUTO	<zero length>	EMPTY	
Image Acquisition Results					
Modality	(0008,0060)	AUTO	"XA"	ALWAYS	
Study ID	(0020,0010)	MWL/USER	from Requested Procedure ID or user input	VNAP	
Performed Protocol Code Sequence	(0040,0260)	MWL	from Scheduled Protocol Code Sequence or <zero length>	VNAP	
>Code Value	(0008,0100)	MWL	from MWL Worklist	ANAP	
>Coding Scheme Designator	(0008,0102)	MWL	from MWL	ANAP	

Attribute	Tag	Source	Value	Presence	Comments
>Coding Scheme Version	(0008,0103)	MWL	from MWL	ANAP	
>Code Meaning	(0008,0104)	MWL	from MWL	ANAP	
Performed Series Sequence	(0040,0340)	AUTO	<zero length>	EMPTY	
Billing and Material Management					
Billing Procedure Step Sequence	(0040,0320)	AUTO	<zero length>	EMPTY	
Film Consumption Sequence	(0040,0321)	AUTO	<zero length>	EMPTY	
Radiation Dose					
Total Time of Fluoroscopy	(0040,0300)	AUTO	<zero length>	EMPTY	
Total Number of Exposures	(0040,0301)	AUTO	<zero length>	EMPTY	
Entrance Dose In mGy	(0040,8302)	AUTO	<zero length>	EMPTY	
Image and Fluoroscopy Area Dose Product	(0018,115E)	AUTO	<zero length>	EMPTY	
Exposure Dose Sequence	(0040,030E)	AUTO	<zero length>	EMPTY	
Distance Source to Detector	(0018,1110)	AUTO	<zero length>	EMPTY	
Comments on Radiation Dose	(0040,0310)	AUTO	<zero length>	EMPTY	

The abbreviations used in the "Source" Column are

- MWL: The attribute value is copied from Modality Worklist.
- USER: The attribute value is entered by the user.
- AUTO: The attribute value is generated by the system.
- CONFIG: The attribute value is obtained by configuration

The abbreviations used in the "Presence" column are

- VNAP: Value is Not Always Present. Attribute is sent zero length if no value is present.
- ANAP: Attribute Not Always Present.
- ALWAYS: Attribute and Value are always present.
- EMPTY: Attribute is sent zero length.

4.2.6.3.2 Activity "Update Modality Performed Procedure Step"

4.2.6.3.2.1 Description and Sequencing of Activities

At the end of examination, the status of the MPPS Instance is set to "COMPLETED".

For "MPPS Complete" the same Presentation Contexts as with "Patient registered" are proposed. Please see related table in section 4.2.6.3.1.2.

4.2.6.3.2.2 SOP specific Conformance for MPPS SOP class

The Performed Procedure Step SCU interprets the following N-SET status codes as Success:

Table 23: MPPS N-SET-RSP Status Handling Behavior

Service Status	Further Meaning	Error Code
Success	MPPS Instance created.	0000

Attributes for the Performed procedure Step N-SET

The Siemens CIARTIC Family DICOM Modality Performed Procedure Step SCU informs the remote SCP about the performed examination and its status. The last MPPS N-SET (final MPPS) has the Performed Procedure Step Status = "COMPLETED".

The following table describes the supported attributes of a N-SET message:

Attribute	Tag	Source	Value	Presence	Comments
Performed Procedure Step Information					
Performed Location	(0040,0243)	AUTO	<zero length>	EMPTY	
Performed Procedure Step End Date	(0040,0250)	AUTO	created	VNAP	only in final N-SET
Performed Procedure Step End Time	(0040,0251)	AUTO	created	VNAP	only in final N-SET
Performed Procedure Step Status	(0040,0252)	AUTO	"IN PROGRESS", "COMPLETED"	ANAP	
Performed Procedure Step Description	(0040,0254)	MWL/USER	from SPS Description or user input	ANAP	
Performed Procedure Type Description	(0040,0255)	AUTO	<zero length>	EMPTY	
Procedure Code Sequence	(0008,1032)	MWL	<zero length>	EMPTY	
Image Acquisition Results					
Performed Protocol Code Sequence	(0040,0260)	MWL	from Scheduled Protocol Code Sequence	ANAP	
>Code Value	(0008,0100)	MWL	from MWL	ANAP	

Attribute	Tag	Source	Value	Presence	Comments
>Coding Scheme Designator	(0008,0102)	MWL	from MWL	ANAP	
>Coding Scheme Version	(0008,0103)	MWL	from MWL	ANAP	
>Code Meaning	(0008,0104)	MWL	from MWL	ANAP	
Performed Series Sequence	(0040,0340)	AUTO		ALWAYS	
>Performing Physician Name	(0008,1050)	MWL/USER	from MWL or user input	VNAP	
>Protocol Name	(0018,1030)	AUTO	from related SOP Instance	ANAP	
> Operators' Name	(0008,1070)	USER	user input	VNAP	
>Series Instance UID	(0020,000E)	AUTO	from related SOP Instance	ANAP	
>Series Description	(0008,103E)	AUTO	from related SOP Instance	VNAP	
>Retrieve AE Title	(0008,0054)	AUTO	<zero length>	EMPTY	
>Referenced Image Sequence	(0008,1140)	AUTO	Series related SOP Instances as items	VNAP	
>> Referenced SOP Class UID	(0008,1150)	AUTO		ANAP	
>> Referenced SOP Instance UID	(0008,1155)	AUTO		ANAP	
>Referenced Non-Image Composite SOP Instance Sequence	(0040,0220)	AUTO	Only for dose report	VNAP	
Billing and Material Management					
Billing Procedure Step Sequence	(0040,0320)	AUTO	<zero length>	EMPTY	
Film Consumption Sequence	(0040,0321)	AUTO	one item for each film size	ANAP	
>Number of Films	(2100,0170)	AUTO		ANAP	
>Film Size ID	(2010,0050)	AUTO		ANAP	
Radiation Dose					
Distance Source to Detector	(0018,1110)	AUTO	minimum value	ANAP	
Total Time of Fluoroscopy	(0040,0300)	AUTO	total fluoro time ("pedal time") in seconds for this procedure step	ALWAYS	
Total Number of Exposures	(0040,0301)	AUTO	total number of irradiation events for this procedure step	ALWAYS	

Attribute	Tag	Source	Value	Presence	Comments
Distance Source to Entrance	(0040,0306)	AUTO	minimum value	VNAP	
Entrance Dose In mGy	(0040,8302)	AUTO	accumulated over complete procedure step	ALWAYS	
Image and Fluoroscopy Area Dose Product	(0018,115E)	AUTO	accumulated over complete procedure step (dGy*cm ²)	ALWAYS	
Exposure Dose Sequence	(0040,030E)	AUTO	one item for each irradiation event (acquisition or fluoro) if configured	ANAP	
>KVP	(0018,0060)	AUTO	peak KV used for this event (KV)	ANAP	
>X-Ray Tube Current in μ A	(0018,8151)	AUTO	tube current used for this event	ANAP	
>Exposure Time	(0018,1150)	AUTO	time of x-ray in ms for this event	ANAP	
> Exposure Time in μ S	(0018,8150)	AUTO	time of x-ray in μ s for this event	ANAP	
>Filter Type	(0018,1160)	AUTO	Filter Type	ANAP	
> Entrance Dose in mGy	(0040,8302)	AUTO	n.a.	ANAP	
> Distance Source to Detector	(0018,1110)	AUTO	SID for this irradiation event	ANAP	
> Image and Fluoroscopy Area Dose Product	(0018,115E)	AUTO	n.a.	ANAP	
> Relative X-Ray Exposure	(0018,1405)	AUTO	Exposure index	ANAP	
>Protocol Name	(0018,1030)	AUTO	Name of the used organ program or fluoro program.	ANAP	

The abbreviations used in the "Source" Column are

- MWL: The attribute value is copied from Modality Worklist.
- USER: The attribute value is entered by the user.
- AUTO: The attribute value is generated by the system.
- CONFIG: The attribute value is obtained by configuration

The abbreviations used in the "Presence" column are

- VNAP: Value is Not Always Present. Attribute is sent zero length if no value is present.
- ANAP: Attribute Not Always Present.
- ALWAYS: Attribute and Value are always present.
- EMPTY: Attribute is sent zero length.

Performed Procedure Step ID without MPPS option

Handling of Performed Procedure Step ID in case

- MPPS is not configured or
- Unscheduled case

The attribute "Performed Procedure Step ID" (0040,0235) will be encoded based on Modality Type = XA and DateTime of the first acquired image. The "Performed Procedure Step ID" stays the same for all acquired or derived images as long as the patient is registered.

4.2.6.4 Association Acceptance Policy

The CIARTIC Family does not provide the functionality of an SCP of the Modality Performed Procedure Step SOP Class.

4.2.7 Print AE Specification

4.2.7.1 SOP Classes

The Print AE provides Standard Conformance to the SOP Classes listed in "Table 1: Network Services" section "Print Management" in the "[Conformance Statement Overview](#)".

4.2.7.2 Association Policy

Whenever a film-sheet is completely set up and printed by command or automated rule, the job is prepared for processing. As soon as the queue is ready to process the job, it is activated and worked according to the processing data. The Print application will initiate an association to the print destination and process the printing.

The default PDU size used will be 64KB.

The CIARTIC Family DICOM application initiates one association at a time for each different print device configured.

4.2.7.2.1 Asynchronous Nature

The CIARTIC Family DICOM print application does not support asynchronous communication (multiple outstanding transactions over a single association).

4.2.7.3 Association Initiation Policy

Triggered by the Print job queue the Print Management SCU establishes an association by using the DICOM association service s. An N-GET request determines the printer status prior to printing. If the printer status is "normal", the print job is started.

4.2.7.3.1 Activity "Print Film"

4.2.7.3.1.1 Description and Sequencing of Activities

Depending on the film sheet layout all corresponding images are sent via Image Box SOP Class. If the response from the remote application contains a status other than Success or Warning the association is aborted.

4.2.7.3.1.2 Proposed Presentation Context

The CIARTIC Family proposes Presentation Contexts as shown in the following table:

Table 24: Presentation Contexts for the Activity “Print Film”

Abstract Syntax		Transfer Syntax		Role	Ext. Neg.
Name	UID	Name List	UID List		
Basic Grayscale Print Management Meta SOP Class	1.2.840.10008.5.1.1.9	Implicit VR Little Endian Explicit VR Little Endian Explicit VR Big Endian	1.2.840.10008.1.2 1.2.840.10008.1.2.1 1.2.840.10008.1.2.2	SCU	None
Basic Film Session SOP Class	1.2.840.10008.5.1.1.1	Implicit VR Little Endian Explicit VR Little Endian Explicit VR Big Endian	1.2.840.10008.1.2 1.2.840.10008.1.2.1 1.2.840.10008.1.2.2	SCU	None
Basic Film Box SOP Class	1.2.840.10008.5.1.1.2	Implicit VR Little Endian Explicit VR Little Endian Explicit VR Big Endian	1.2.840.10008.1.2 1.2.840.10008.1.2.1 1.2.840.10008.1.2.2	SCU	None
Basic Grayscale Image Box SOP Class	1.2.840.10008.5.1.1.4	Implicit VR Little Endian Explicit VR Little Endian Explicit VR Big Endian	1.2.840.10008.1.2 1.2.840.10008.1.2.1 1.2.840.10008.1.2.2	SCU	None
Printer SOP Class	1.2.840.10008.5.1.1.16	Implicit VR Little Endian Explicit VR Little Endian Explicit VR Big Endian	1.2.840.10008.1.2 1.2.840.10008.1.2.1 1.2.840.10008.1.2.2	SCU	None
Presentation LUT SOP Class	1.2.840.10008.5.1.1.23	Implicit VR Little Endian Explicit VR Little Endian Explicit VR Big Endian	1.2.840.10008.1.2 1.2.840.10008.1.2.1 1.2.840.10008.1.2.2	SCU	None

4.2.7.3.1.3 SOP Specific Conformance

The CIARTIC Family Print SCU conforms to the DICOM Basic Grayscale Print Management Meta SOP Class.

The application uses a configuration platform to define the properties of the connected DICOM SCP, e. g.:

- maximum number of print copies
- supported film formats of the DICOM SCP

The printing is only suspended in the case of a failure return status of the SCP.

Basic Film Session SOP Class

The Basic Film Session information object definition describes all the user-defined parameters, which are common for all the films of a film session. The Basic Film Session refers to one or more Basic Film Boxes that are printed on one hardcopy printer.

The CIARTIC Family Print Management SCU supports the following DIMSE Service elements for the Basic Film Session SOP Class as SCU:

- N-CREATE
- N-DELETE

The Basic Film Session SOP Class N-CREATE-RQ (SCU) uses the attributes listed in the table below:

Table 25: Attributes for the N-CREATE-RQ of the Basic Film Session

Attribute Name	Tag	Usage SCU	Supported Values
Number of Copies	(2000,0010)	U	Set by user. 1 - 9
Print Priority	(2000,0020)	U	“MED”

Medium Type	(2000,0030)	U	"BLUE FILM"
-------------	-------------	---	-------------

U = User Option

The Affected SOP Instance UID received with N-CREATE-RSP message will be kept internally and used for later requests (e. g. N-DELETE-RQ) on the Basic Film Session.

Table 26: Requested SOP Instance UID on the Basic Film Session

Attribute Name	Tag	Source of Information
Requested SOP Instance UID	(0000,1000) -> (0000,1001)	Affected SOP Instance UID of N-CREATE-RSP on Basic Film Session

The Basic Film Session SOP class interprets the status codes (from N-CREATE-RSP messages) listed in the table below:

Table 27: N-CREATE-RSP Status Handling Behavior for the Basic Film Session

Service Status	Further Meaning	Error Codes
Failure	Unable to create print job, print queue is full	C601
	Image size is larger than images box size	C603
Warning	Requested MinDensity or MaxDensity outside of Printer's operating range	B605
	Film box does not contain image box (empty page)	B602
Success	Film belonging to the film session are accepted for printing	0000

The N-DELETE-RQ on the Basic Film Session SOP Class is used to remove the complete Basic Film Session SOP Instance hierarchy.

Basic Film Box SOP Class

The Basic Film Box information object definition describes all user-defined parameters of one film of the film session including presentation parameters, which are common for all images on a given film sheet.

The Basic Film Box refers to one or more Image Boxes.

The CIARTIC Family Print Management SCU supports the following DIMSE Service elements for the Basic Film Box SOP Class as SCU:

- N-CREATE
- N-ACTION
- N-DELETE

The Basic Film Box SOP Class N-CREATE-RQ message uses the attributes listed below. The actual values for each attribute depend on DICOM printer configuration within the CIARTIC Family DICOM Print Management SCU:

Table 28: Attributes for the N-CREATE-RQ of the Basic Film Box

Attribute Name	Tag	Usage SCU	Supported Values
Image Display Format	(2010,0010)	M	1,1
Referenced Film Session Sequence	(2010,0500)	M	
> Referenced SOP Class UID	(0008,1150)	M	1.2.840.10008.5.1.1.1

Attribute Name	Tag	Usage SCU	Supported Values
> Referenced SOP Instance UID	(0008,1155)	M	UID of Film Session
Film Orientation	(2010,0040)	M	(from Camera configuration) "PORTRAIT", "LANDSCAPE"
Film Size ID	(2010,0050)	M	(from Camera configuration) 8INX10IN, 10INX12IN, 11INX14IN, 4INX14IN, 14INX17IN
Magnification Type	(2010,0060)	M	"NONE"
Boarder Density	(2010,0100)	M	"BLACK"
Min Density	(2010,0120)	M	20
Max Density	(2010,0130)	M	300
Referenced Presentation LUT Sequence	(2050,0500)	U	only when Presentation LUT SOP Class is supported (see DICOM Grayscale Presentation States)
>Referenced SOP Class UID	(0008,1150)	U	"1.2.840.10008.5.1.1.23"
>Referenced SOP Instance UID	(0008,1155)	U	Instance UID of Presentation LUT object

M = Mandatory

The N-CREATE-RSP message from the Print SCP includes the Referenced Image Box Sequence with SOP Class/Instance UID pairs which will be kept internally to be further used for the subsequent Basic Image Box SOP Class N-SET-RQ messages.

When all Image Boxes (including parameters) for the film-sheet have been set, the CIARTIC Family print manager will issue an N-ACTION-RQ message with the SOP Instance UID of the Basic Film Box and the Action Type ID of 1.

The affected SOP Instance UID received with N-CREATE-RSP message will be kept internally and used for later requests (e. g., N-DELETE-RQ) on the Basic Film Box.

Table 29: Requested SOP Instance UID on the Basic Film Box

Attribute Name	Tag	Source of Information
Requested SOP Instance UID	(0000,1000) -> (0000,1001)	Affected SOP Instance UID of N-CREATE-RSP on Basic Film Box

The Basic Film Box SOP class interprets the status codes listed in the table below:

Table 30: N-ACTION-RSP Status Handling Behavior for Basic Film Box

Service Status	Meaning	Error Codes
Failure	Unable to create print job, print queue is full	C601
	Image size is larger than images box size	C603
Warning	Film box does not contain image box (empty page)	B603
	Requested Min Density or Max Density outside of printer's operating range.	B605

Service Status	Meaning	Error Codes
Success	Film accepted for printing	0000

Basic Grayscale Image Box SOP Class

The Basic Grayscale Image Box information object definition is the presentation of an image and image related data in the image area of a film. The Basic Image Box information describes the presentation parameters and image pixel data, which apply to a single image of a sheet of film.

The Grayscale Image Box SOP Class uses only the N-SET-RQ with the attributes listed in the table below:

Table 31: Attributes for N-SET-RQ of Basic Grayscale Image Box

Attribute Name	Tag	Usage SCU	Supported Values
Image Position	(2020,0010)	M	Depending on display format
Basic Grayscale Image Sequence	(2020,0110)	M	n.a.
> Samples per Pixel	(0028,0002)	M	1
> Photometric Interpretation	(0028,0004)	M	MONOCHROME2
> Rows	(0028,0010)	M	<Printer/Film config>
> Columns	(0028,0011)	M	<Printer/Film config>
> Pixel Aspect Ratio	(0028,0034)	M	1\1
> Bits Allocated	(0028,0100)	M	8
> Bits Stored	(0028,0101)	M	8
> High Bit	(0028,0102)	M	7
> Pixel Representation	(0028,0103)	M	0
> Pixel Data	(7FE0,0010)	M	n.a.

The Basic Grayscale Image Box SOP class interprets the status codes as listed below:

Table 32: N-SET-RSP Status Handling Behavior for the Basic Grayscale Image Box SOP Class

Service Status	Further Meaning	Error Codes
Failure	Image contains more pixel than printer can print in Image Box	C603
	Insufficient memory in printer to store the image	C605
Warning	Requested MinDensity or MaxDensity outside of Printer's operating range	B605
Success	Image successfully stored in Image Box	0000

Presentation LUT SOP Class

The objective of the Presentation LUT is to realize image hardcopy printing tailored for specific modalities, applications, and user preferences.

The output of the Presentation LUT is Presentation Values (P-Values). P-Values are approximately related to human perceptual response. They are intended to facilitate common input for hardcopy. P-Values are intended to be independent of the specific class or characteristics of the hardcopy device.

The Presentation LUT SOP Class uses only the N-CREATE-RQ with the attributes listed below:

Table 33: Attributes for N-CREATE-RQ of Presentation LUT SOP Class

Attribute Name	Tag	Usage SCU	Supported Values
Presentation LUT Shape	(2050,0020)	U	IDENTITY

The affected SOP Instance UID received with N-CREATE-RSP message will be kept internally and is used for later requests on the Basic Film Box (N-CREATE-RQ) and on the Presentation LUT (N-DELETE-RQ).

Table 34: Requested SOP Instance UID on the LUT

Attribute Name	Tag	Source of Information
Requested SOP Instance UID	(0000,1000) -> (0000,1001)	Affected SOP Instance UID of N-CREATE-RSP on Presentation LUT

The Presentation LUT SOP class interprets the status codes listed below:

Table 35: N-CREATE-RSP Status Handling Behavior for the Presentation LUT SOP Class

Service Status	Further Meaning	Error Codes
Warning	Requested MinDensity or MaxDensity outside of HCD's operating range. HCD will use its respective minimum or maximum density value instead.	B605
Success	Presentation LUT successfully created	0000

Printer SOP Class

The Printer SOP Class provides the possibility to monitor the status of the hardcopy printer in a synchronous and in an asynchronous way.

The CIARTIC Family DICOM print manager can directly ask the Printer (SCP) for its status or receive events from the Printer asynchronously.

- N-GET as SCU
- N-EVENT-REPORT as SCU

In both cases the following returned information is supported:

Table 36: Used Printer N-EVENT Report attributes

Event-type Name	Event	Attributes	Tag	Usage SCU
Normal	1			
Warning	2	Printer Status Info	(2110,0020)	U
Failure	3	Printer Status Info	(2110,0020)	U

U = User Option

Table 37: Mandatory Printer N-GET-RSP, N-EVENT-REPORT-RQ attributes

Attribute Name	Tag	Usage SCP	Supported Values
Printer Status	(2110,0010)	M	NORMAL, FAILURE, WARNING
Printer Status Info	(2110,0020)	M	

M = Mandatory

4.2.7.4 Association Acceptance Policy

n.a.

4.3 Network Interfaces

4.3.1 Physical Network Interface

The CIARTIC Family provides DICOM 3.0 TCP/IP network communication support as defined in Part 8 of the DICOM Standard and uses the TCP/IP protocol stack from the operating system. It uses the MergeCOM subroutine library. All available Ethernet interfaces are supported.

4.3.2 Additional Protocols

None

4.3.3 IPv4 and IPv6 Support

IPv4 and IPv6 are supported. Regarding IPv6 please note, that the complete networking infrastructure in the hospital (firewalls, DNS-Servers, ...) must support IPv6 to get a functioning communication.

4.4 Configuration

4.4.1 AE Title/Presentation Address Mapping

AE Titles must be unique within the hospital. A common way to achieve that is to use the hostname as part of the AE Titles. The string can be up to 16 characters and must not contain any extended characters. Only 7-bit ASCII characters (excluding Control Characters) are allowed according to the DICOM Standard.

4.4.1.1 Local AE Titles

Change of the default AE Titles chosen by the system can be performed in the Service UI under "FLC Service / Configuration / DICOM Local Settings" item - first page.

Table 38: AE Titles

Application Entity	Default Unencrypted AE Title	TCP/IP Port	Default Encrypted AE Title	TCP/IP Port
Storage SCU	FLC_STORE_SCU	-	FLC_STORE_SCU_S	-
Storage SCP	FLC_STORE_SCP	104 (fixed)	FLC_STORE_SCP_S	2762
Query/Retrieve SCU	FLC_STORE_SCU	-	FLC_QR_SCU_S	-
Print SCU	FLC_STORE_SCU	-	FLC_PRINT_SCU_S	-
Worklist SCU	FLC_WK_SCU	-	FLC_WK_SCU_S	-
Storage Commitment SCU	FLC_STC_SCU	-	FLC_STC_SCU_S	-

4.4.1.2 Remote AE Title/Presentation Address Mapping

For each remote AE the following data and capabilities can be configured:

Table 39 - Remote AE Configuration Items

Remote AE Configuration Item	Comment
Host Name	As defined in the network domain. This has to be configured also for any DICOM AE that wishes to connect to SCP services of CIARTIC Family.
TCP/IP address	As defined in the network domain. This has to be configured also for any DICOM AE that wishes to connect to SCP services of CIARTIC Family.
Logical Name (Alias)	Name for the AE used in the user interfaces of the CIARTIC Family applications.
AE Title	AET, as provided by network administration
Port Number	Port Number, as provided by network administration
If Storage Service support is checked	
Archive Node	When checked, sending to remote AET will set status of a(rchived), else s(ent) is indicated.
StC node Server	Select a previously configured alias for Storage Commitment when sending DICOM objects to the configured AE.
If Storage Commitment Service support is checked	
Timeout for Result in same association	Timeout in seconds to wait at the open association.
If Modality Worklist Service support is checked	
No Default Character Set used in Query	Checkbox to activate the option, that no default character set shall be used for the query message. Default: Deactivated.
Query Waiting time	The time in sec (1-999) to wait for the C-FIND-RSP after sending the C-FIND-RQ (default 20 sec.)
Max Query Match Number	The maximum number of entries accepted in one worklist (default is 200)
Query Interval	The time between two C-FIND-RQ to the Hospital Information system (default is 60 min, minimum is 3 min, maximum is 1440 min i.e. 24 hours)
Time Range	User configuration: +/- n hours

4.4.1.2.1 Remote Association Acceptors

For remote applications that shall be able to accept DICOM associations from CIARTIC Family, the following information needs to be available:

- Application Entity Title
- Host Name / IP address on which the remote application service runs
- Port number on which the remote application accepts association requests.

The remote system will be indicated in the UI of CIARTIC Family with a logical name, that is also entered when configuring the node in the administration UI.

4.4.1.3 Secure DICOM Communication

The system supports configuring the DICOM communication to use secure channel (TLS) between CIARTIC Family and configured remote nodes.

The certificates that are needed for the secure DICOM communication are stored in the Windows Certificate Store.

The secure communication between the local node and the remote node will not be established and fail, if one of the following conditions is fulfilled:

- local/remote certificate is expired
- remote certificate is tampered
- certificate from remote device signed by a Certificate Authority that is not trusted locally

Note: The default DICOM port will change to 2762.

4.4.2 Parameters

The next table lists configuration parameters, which are applicable for all Application Entities.

Table 40: Parameter List

Time-out Values				
Parameter	Default Value[sec]	Min [sec]	Max [sec]	Comment
Accepting/Rejecting an Association Request	60	15	600	Wait for an Association Request or wait for a Peer to shut down the Association
Association Open Request	60	15	600	Wait for a reply to an Association Accept Request
Association Close Request	60	15	600	Wait for a reply to an Association Release Request
Accepting a Message over Network	60	15	600	Wait for a Network Write to be accepted
Waiting for Data between TCP/IP Packets	60	15	600	Wait for Data between TCP/IP packets
Accept network connect	15	15	600	Wait for a Network Connect to be accepted
General Transfer Setting				
Simultaneous DICOM associations	10	1	10	Number of simultaneous associations running.
Maximum PDU Size	64kByte	4kByte	1MByte	Proposed PDU size, each selectable value is doubled from previous, starting with 4kB. Additionally, for optimization for some networks 28kByte are provided.

5 Media Interchange

5.1 Implementation Model

5.1.1 Application Data Flow Diagram

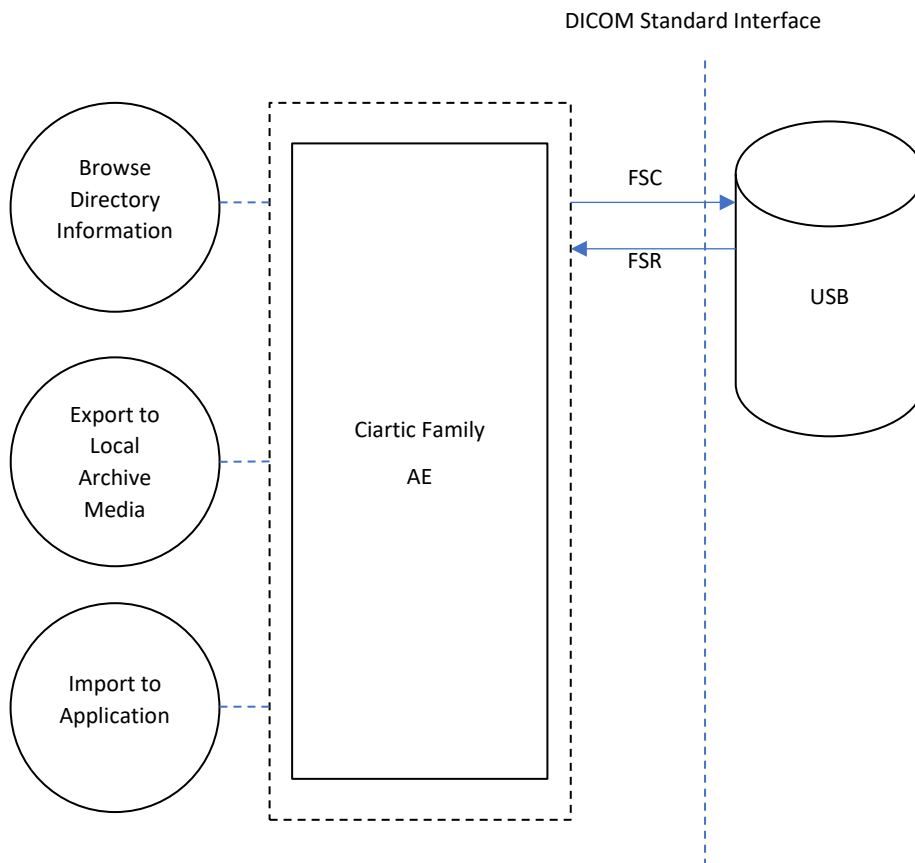

Figure 5: Media Interchange Application Data Flow Diagram

The DICOM Archive application will serve as an interface to the USB offline medium device.

The DICOM Archive application will support the USB medium.

The FSU role will update new SOP Instances only to media with pre-existing File-sets conforming to the Application Profiles supported.

The contents of the DICOMDIR will temporarily be stored in Archive-Database.

5.1.2 Functional definitions of AEs

The DICOM Offline Media Storage application consists of the DICOM Archive application entity serving all interfaces to access offline media. The DICOM Archive application is capable of

- creating a new File-set in the File System (Export to ...)
- updating an existing File-set by writing new SOP Instances onto the medium (Export to...).

- importing SOP Instances from the medium onto local storage
- reading the File-sets DICOMDIR information into temporary database and pass it to display applications.

5.1.3 Sequencing of Real World Activities

The DICOM Archive application will not perform transfers until the Directory information of the DICOMDIR is completely read in and displayed in the Browser.

5.2 AE Specifications

5.2.1 Media Storage AE – Specification

The *CIARTIC Family* provides conformance to the following Application Profiles:

Table 41: Media - Application Profiles and Real World Activities

Application Profiles Supported	Real World Activity	Role	Service Class Option
STD-GEN-USB-JPEG	Browse Directory Information	FSR	Interchange
	Import into local Storage	FSR	
	Export to local Archive Media	FSC, FSU	

5.2.1.1 Real World Activities

5.2.1.1.1 Activity “Browse Directory Information”

The *CIARTIC Family* acts as FSR using the interchange option when requested to read the media directory.

The *CIARTIC Family* will read the DICOMDIR and insert those directory entries that are valid for the application profiles supported, into a local database. The database then is used for browsing media contents.

Note: The “Icon Image Sequence” is also supported in DICOMDIR. But only those Icon Images with “Bits Allocated” (0028,0100) equal to 8 and size of 64x64 or 128x128 pixels are imported into database and are visible in the Browser.

5.2.1.1.2 Activity “Import into Application”

The *CIARTIC Family* application acts as FSR using the interchange option when requested to read SOP Instances from the medium into the application.

The SOP Instance selected from the media directory will be copied into the running Application. Only SOP Instances, that are valid for the application profile supported and supported by CIARTIC Family can be retrieved from media.

For media conforming to the STD-GEN-xxx Profile the following SOP Classes will be supported as FSR:

Table 42: STD-GEN-xxx profile supported SOP Classes

Information Object Definition	Transfer Syntax UID
Any image SOP Class detailed in Table 1: Network Services section "Transfer (Image SOP Class)".	Explicit VR Little Endian 1.2.840.10008.1.2.1

5.2.1.1.3 Activity “Export to local Archive Media”

The CIARTIC Family application acts as FSU (for media with existing DICOM file-set) or FSC (media not initialized) using the interchange option when requested to copy SOP Instances from the local storage to local Archive Medium.

The CIARTIC Family application will receive a list of SOP Instances to be copied to the local archive medium. According to the state of the medium inserted (new medium, Medium with DICOM file-set) the validity of the SOP Instances according to the applicable profile is checked. Only valid SOP Instances are accepted.

Table 43: STD-GEN-xxx profile supported SOP Classes

Information Object Definition	Transfer Syntax UID
X-Ray Angiographic Image Storage	Explicit VR Little Endian 1.2.840.10008.1.2.1
X-Ray Radiation Dose SR	
CT Image Storage	
Enhanced CT Image Storage	
Secondary Capture Image Storage (as Exam Protocol)	
Multi-frame True Color Secondary Capture Image Storage	

The DICOM Archive application will not finalize the medium.

With the resizing feature of the CIARTIC Family DICOM application, downsized images (8bit) as well as processed images can be written onto medium.

Restrictions and Extensions:

- The DICOM Offline Storage application supports only SOP Instances generated by the application.

5.2.2 Augmented Application Profiles

n.a.

5.3 Media Configuration

n.a.

6 Support of Extended Character Sets

The CIARTIC Family DICOM application supports the following character sets as defined below:

- ISO_IR 100 (ISO 8859-1:1987 Latin Alphabet No. 1 supplementary set)
- ISO_IR 144 (Cyrillic, supplementary set of ISO 8859, used when Russian patient data input is configured)
- GB18030 (used when Chinese patient data input is configured)
- ISO 2022 IR 13, ISO 2022 IR 87 and ISO 2022 IR 159 (used when Japanese patient data input is configured)

7 Attribute confidentiality profiles

7.1 Data Minimization

The **CIARTIC Family** application can minimize attributes of self-created DICOM image objects/dose reports, when exporting to Media.

Table 44: Application Level Confidentiality Profile attributes (standard tags)

DICOM Tag	Attribute Name	Minimized
(0008,0020)	Study Date	Yes
(0008,0021)	Series Date	Yes
(0008,0022)	Acquisition Date	Yes
(0008,0023)	Content Date	Yes
(0008,0050)	Accession Number	Yes
(0008,0080)	Institution Name	Yes
(0008,0081)	Institution Address	Yes
(0008,0090)	Referring Physician's Name	Yes
(0008,1010)	Station Name	Yes
(0008,1030)	Study Description	Yes
(0008,103E)	Series Description	Yes
(0008,1040)	Institutional Department Name	Yes
(0008,1048)	Physicians of Record	Yes
(0008,1050)	Performing Physician's Name	Yes
(0008,1070)	Operator's Name	Yes
(0008,1080)	Admitting Diagnoses Description	Yes
(0008,1110)	Referenced Study Sequence	Yes
(0008,1120)	Referenced Patient Sequence	Yes
(0008,2111)	Derivation Description	Yes
(0010,0010)	Patient's Name	Yes
(0010,0020)	Patient ID	Yes
(0010,0030)	Patient's Birth Date	Yes
(0010,0040)	Patient's Sex	Yes
(0010,1001)	Other Patient Names	Yes
(0010,1010)	Patient's Age	Yes
(0010,1020)	Patient's Size	Yes
(0010,1030)	Patient's Weight	Yes
(0010,1040)	Patient's Address	Yes

DICOM Tag	Attribute Name	Minimized
(0010,1080)	Military Rank	Yes
(0010,2160)	Ethnic Group	Yes
(0010,21B0)	Additional Patient History	Yes
(0010,4000)	Patient Comments	Yes
(0018,1000)	Device Serial Numbers	Yes
(0018,1030)	Protocol Name	Yes
(0020,0010)	Study ID	Yes
(0038,0010)	Admission ID	Yes
(0038,0300)	Current Patient Location	Yes
(0040,0006)	Scheduled Performing Physician Name	Yes ¹
(0040,0275)	Request Attributes Sequence	Yes
(0040,A730)	Content Sequence	Yes
Additional in Dose SR		
121008	Person Observer Name	Yes

¹ Scheduled Performing Physician's Name (0040,0006)" is not directly included in the header. However, its value is stored in the header as "Performing Physician's Name (0008,1050)", which is deidentified.

8 Security

The CIARTIC Family is supporting security by having the firewall of the underlying operating system active. Besides the standard ports of the operating system, only the DICOM Ports (104, 2762) are opened.

CIARTIC Family only accepts DICOM communication from other AE if the related System is configured with its hostname, port and AET.

8.1 Security Profiles

FLC supports the “BCP 195 RFC 8996 TLS Secure Transport Connection Profile” as specified in [DICOM]. TLS version 1.2. is supported. The cypher suites that are provided by the underlying Operating System are used. The private key and certificate used by an FLC based system and Certificate Authorities (CA) to validate certificates received from remote nodes are stored in the local Certificate Store of the underlying Operating System. The listening port used for the DICOM services is 2762.

9 Annexes

9.1 IOD Contents

9.1.1 Created SOP Instances

The following tables use a number of abbreviations. The abbreviations used in the “Presence” column are

- VNAP: Value is Not Always Present. Attribute is sent zero length if no value is present.
- ANAP: Attribute Not Always Present.
- ALWAYS: Attribute and Value are always present.
- EMPTY: Attribute is sent zero length.

The abbreviations used in the “Source” Column are

- MWL: The attribute value is copied from Modality Worklist.
- USER: The attribute value is entered by the user.
- AUTO: The attribute value is generated by the system.
- CONFIG: The attribute value is obtained by configuration

9.1.1.1 X-Ray Angiographic Image IOD – Acquired and Derived Images

The CIARTIC Family system creates images during acquisition and with post processing applications. These will be encoded as XA Standard Extended SOP Class. Please see the following table for a complete overview of supplied Type 1/2/3 Standard and additional Private Attributes:

Table 45: IOD of Created XA SOP Instances – Acquired and Derived Images

IE	Module	Reference	Presence of Module
Patient	Patient Module	Table 51	ALWAYS
Study	General Study Module	Table 52	ALWAYS
	Patient Study	Table 53	ALWAYS
Series	General Series and Enhanced Series	Table 54	ALWAYS
Equipment	General Equipment	Table 55	ALWAYS
Image	General Image	Table 56	ALWAYS
	Image Pixel	Table 57	ALWAYS
	Contrast/Bolus	Table 63	ALWAYS
	Cine	Table 64	ANAP
	Multi-frame	Table 59	ALWAYS
	Frame Pointers	Table 65	ANAP
	Mask	Table 66	ANAP
	X-Ray Image	Table 67	ALWAYS
	X-Ray Acquisition	Table 69	ALWAYS
	X-Ray Collimator	Table 70	ANAP

IE	Module	Reference	Presence of Module
	XA Positioner	Table 71	ALWAYS
	DX Detector	Table 72	ALWAYS
	Modality LUT	Table 73	ALWAYS
	VOI LUT	Table 61	ALWAYS
	SOP Common	Table 58	ALWAYS
	Private Data Element Dictionary - SIEMENS_FLCOMPACT_VA01A_PROC	Table 85	ALWAYS
	Private Data Element Dictionary – Siemens: Thorax/Multix FD Lab Settings	Table 86	ALWAYS
	Private Data Element Dictionary - Siemens: Thorax/Multix FD Raw Image Settings	Table 89	ALWAYS
	Private Data Element Dictionary - Siemens: Thorax/Multix FD Post Processing	Table 87	ALWAYS

9.1.1.2 Enhanced CT Standard SOP Class

The CIARTIC Family system will create a volume, and optionally also partial volumes and parallel ranges, during 3D acquisition, which is encoded as Enhanced CT SOP Class. It is also possible to send the volume utilizing the singleframe CT SOP Class. Please see the following tables for a complete overview of supplied Type 1/2/3 Standard Attributes:

Table 46: IOD of Enhanced CT Volume

IE	Module	Reference	Presence of Module
Patient	Patient Module	Table 51	ALWAYS
Study	General Study Module	Table 52	ALWAYS
	Patient Study	Table 53	ALWAYS
Series	General Series and Enhanced Series	Table 54	ALWAYS
Frame of Reference	Frame of Reference	Table 60	ALWAYS
Equipment	General Equipment	Table 55	ALWAYS
Image	Image Pixel	Table 57	ALWAYS
	Multi-Frame Functional Groups	Table 74	ALWAYS
	SOP Common	Table 58	ALWAYS
	Acquisition Context	Table 77	ALWAYS
	Overlay Plane	Table 62	Not always present
	Multi-frame Overlay	Table 78	Not always present
	Enhanced CT Image	Table 76	ALWAYS
	Multi-Frame Dimension	Table 75	ALWAYS
	Private Data Element Dictionary - Siemens: Thorax/Multix FD Post Processing	Table 87	ALWAYS
	Private Data Element Dictionary - Siemens: VDM_VA30	Table 88	ALWAYS
Private Data Element Dictionary - ISOC 3D NAVIGATIONMATRIX.R. 2.0	Table 90	ALWAYS	

9.1.1.3 CT Standard SOP Class

The CIARTIC Family system will create a volume, and optionally also partial volumes and parallel ranges, during 3D acquisition, which is encoded as Enhanced CT SOP Class. It is also possible to send the volume utilizing the singleframe CT SOP Class. Please see the following tables for a complete overview of supplied Type 1/2/3 Standard Attributes:

Table 47: IOD of CT Volume

IE	Module	Reference	Presence of Module
Patient	Patient Module	Table 51	ALWAYS
Study	General Study Module	Table 52	ALWAYS
	Patient Study	Table 53	ALWAYS
Series	General Series and Enhanced Series	Table 54	ALWAYS
Frame of Reference	Frame of Reference	Table 60	ALWAYS
Equipment	General Equipment	Table 55	ALWAYS
Image	General Image	Table 56	ALWAYS
	Image Pixel	Table 57	ALWAYS
	Image Plane	Table 79	ALWAYS
	SOP Common	Table 58	ALWAYS
	CT Image Module	Table 80	ALWAYS
	Overlay Plane Module	Table 62	Not always present
	VOI LUT	Table 61	ALWAYS
	Private Data Element Dictionary - Siemens: VDM_VA30	Table 88	ALWAYS
	Private Data Element Dictionary - Siemens: Thorax/Multix FD Post Processing	Table 87	ALWAYS
	Private Data Element Dictionary - ISOC 3D NAVIGATIONMATRIX.R. 2.0	Table 90	ALWAYS

9.1.1.4 Multiframe True Color Secondary Capture Image

The CIARTIC Family system will create functional images from 3D acquisition, which is encoded as Multiframe True Color Secondary Capture SOP Class. Please see the following tables for a complete overview of supplied Type 1/2/3 Standard Attributes:

Table 48: IOD of Multiframe True Color Secondary Capture Image

IE	Module	Reference	Presence of Module
Patient	Patient Module	Table 51	ALWAYS
Study	General Study Module	Table 52	ALWAYS
	Patient Study	Table 53	ALWAYS
Series	General Series and Enhanced Series	Table 54	ALWAYS
Equipment	General Equipment	Table 55	ALWAYS
	SC Equipment	Table 81	ALWAYS
Image	General Image	Table 56	ALWAYS
	Image Pixel	Table 57	ALWAYS
	Multi-frame	Table 59	ALWAYS
	SOP Common	Table 58	ALWAYS
	Private Data Element Dictionary - SIEMENS_FLCOMPACT_VA01A_PROC	Table 85	ALWAYS

9.1.1.5 Exam Protocol as Secondary Capture Image IOD

The CIARTIC Family will generate an X-Ray Radiation Dose SR object to store all dose and acquisition relevant information for all irradiation events. An excerpt of this information is displayed to the user as "Exam Protocol". This displayed Exam Protocol can be converted to an SC image. The pixel data contain the protocol data as an image.

All patient level, study level and equipment information is taken from the acquired images of the related procedure.

Acquisition specific information (e.g. KVP, mA) and further information is set either to default values (type 1), set to zero length (type 2) or not set at all.

Table 49: IOD of Created Secondary Capture SOP Instances

IE	Module	Reference	Presence of Module
Patient	Patient Module	Table 51	ALWAYS
Study	General Study Module	Table 52	ALWAYS
	Patient Study	Table 53	ALWAYS
Series	General Series and Enhanced Series	Table 54	ALWAYS
Equipment	General Equipment	Table 55	ALWAYS
	SC Equipment	Table 81	ALWAYS
Image	General Image	Table 56	ALWAYS
	Image Pixel	Table 57	ALWAYS
	SOP Common	Table 58	ALWAYS
	Private Data Element Dictionary - SIEMENS_FLCOMPACT_VA01A_PROC	Table 85	ALWAYS

9.1.1.6 X-Ray Radiation Dose SR IOD

The CIARTIC Family creates X-Ray Radiation Dose SRs implementing TID 10001 Projection X-Ray Radiation Dose.

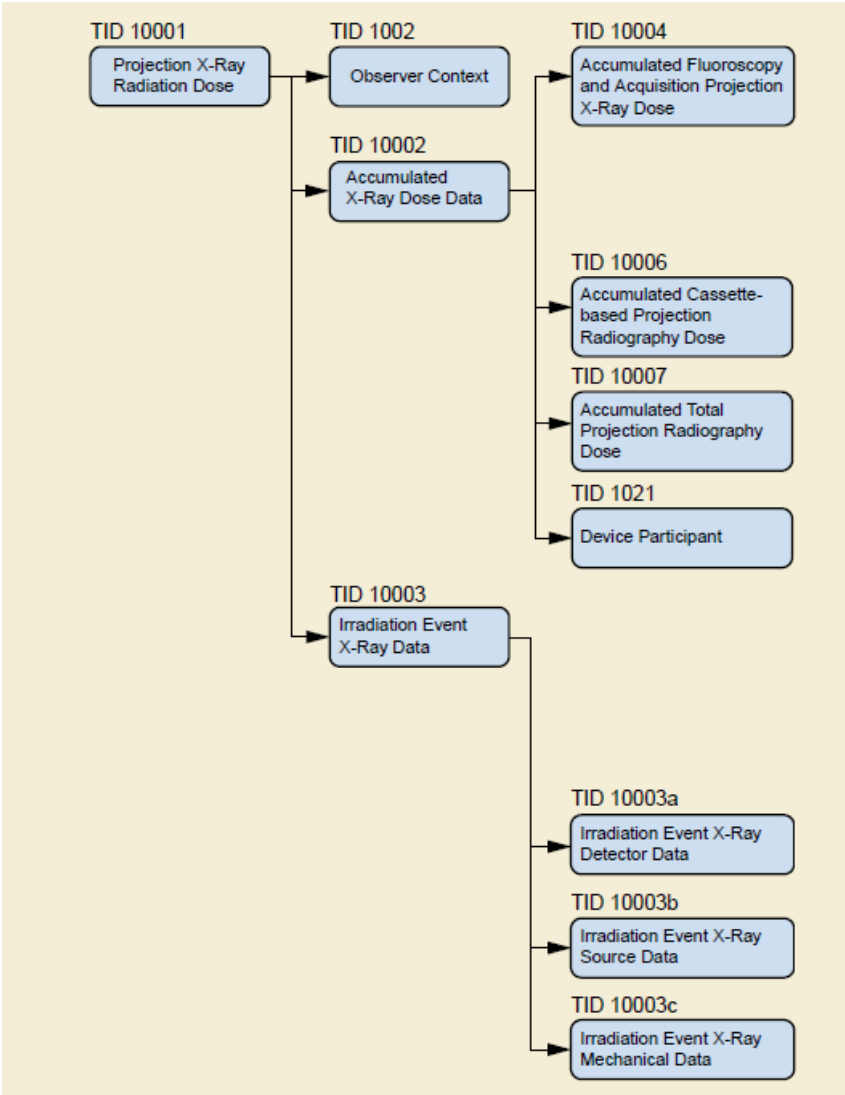

Figure 6: X-Ray Radiation Dose SR IOD Template Structure

The report is kept open (Completion Flag (0040,A491) = "PARTIAL") to support continuation of the study. Updating of a SR will not change the SOP Instance UID. Closing a study will set the Completion Flag (0040,A491) to "COMPLETED".

All patient level, study level and equipment information is taken from the acquired images. The related attribute mapping from Modality Worklist to X-Ray Radiation Dose SR is equal to the mapping into acquired images. Please refer to Table 13: Proposed Presentation Contexts for Retrieve and Activity "Send Move Request" for mapping of worklist information.

Table 50: IOD of Created X-Ray Radiation Dose SR SOP Instances

IE	Module	Reference	Presence of Module
Patient	Patient Module	Table 51	ALWAYS

IE	Module	Reference	Presence of Module
Study	General Study Module	Table 52	ALWAYS
	Patient Study	Table 53	ALWAYS
Series	SR Document Series	Table 82	ALWAYS
Equipment	General Equipment	Table 55	ALWAYS
Document	SR Document General	Table 83	ALWAYS
	SR Document Content	Table 84	ALWAYS
	SOP Common	Table 58	ALWAYS

9.1.1.7 Common Modules

Table 51: Patient Module

Attribute	Tag	Source	Value	Presence	Comments
Referenced Patient Sequence	(0008,1120)	MWL	From MWL	ANAP	Only for XA, Dose SR, SC and Colored mf SC
>Referenced SOP Class UID	(0008,1150)	MWL	From MWL	ANAP	
>Referenced SOP Instance UID	(0008,1155)	MWL	From MWL	ANAP	
Patient's Name	(0010,0010)	MWL/USER	From MWL or user input	ALWAYS	
Patient ID	(0010,0020)	MWL/USER	From MWL or user input	ALWAYS	
Patient's Birth Date	(0010,0030)	MWL/USER	From MWL or user input	VNAP	
Patient's Sex	(0010,0040)	MWL/USER	From MWL or user input (M or F or O)	ALWAYS	
Other patient IDs	(0010,1000)	MWL	From MWL	ANAP	Only in CT and eCT
Other Patient Names	(0010,1001)	MWL	From MWL	ANAP	
Ethnic Group	(0010,2160)	MWL	From MWL	ANAP	
Patient Comments	(0010,4000)	MWL/USER	Additional Info	ANAP	
Patient's Address	(0010,1040)	MWL	Patient's Address	VNAP	Standard Extended Attribute. For XA, SC, RDSR and Colored mf SC
				ANAP	Standard Extended Attribute. For eCT and CT
Military Rank	(0010,1080)	MWL	From MWL	VNAP	Standard Extended Attribute. For XA, SC, RDSR and Colored mf SC
				ANAP	Standard Extended Attribute. For eCT and CT

Table 52: General Study Module

Attribute	Tag	Source	Value	Presence	Comments
Study Date	(0008,0020)	AUTO		ALWAYS	
Study Time	(0008,0030)	AUTO		ALWAYS	
Accession Number	(0008,0050)	MWL/USER	From MWL or user input	VNAP	

Attribute	Tag	Source	Value	Presence	Comments
Referring Physician's Name	(0008,0090)	MWL/USER	From MWL or user input	VNAP	
Study Description	(0008,1030)	MWL/AUTO/User	Requested Procedure Description (0032,1060) from MWL, Application Group of user input	ALWAYS	
Procedure Code Sequence	(0008,1032)	MWL	Requested Procedure Code Sequence (0032,1062) from Modality Worklist	ANAP	
>Code Value	(0008,0100)	MWL	From MWL	ALWAYS	
>Coding Scheme Designator	(0008,0102)	MWL	From MWL	ALWAYS	
>Coding Scheme Version	(0008,0103)	MWL	From MWL	ANAP	
>Code Meaning	(0008,0104)	MWL	From MWL	ALWAYS	
Referenced Study Sequence	(0008,1110)	MWL	From MWL	ANAP	
>Referenced SOP Class UID	(0008,1150)	MWL	From MWL	ANAP	
>Referenced SOP Instance UID	(0008,1155)	MWL	From MWL	ANAP	
Physicians of Record	(0008,1048)	MWL	From MWL	ANAP	XA, SC, Colored mf SC and RDSR
			-	Not present	eCT, CT
Study Instance UID	(0020,000D)	MWL/AUTO	From MWL or generated by device	ALWAYS	
Study ID	(0020,0010)	MWL	Requested Procedure ID from Worklist	VNAP	
Study Comments	(0032,4000)	USER	Patient Registration input	ANAP	Standard Extended Attribute. Only for XA, SC and Colored mf SC Image

Table 53: Patient Study Module

Attribute	Tag	Source	Value	Presence	Comments
Admitting Diagnoses Description	(0008,1080)	MWL	Admitting Diagnosis	VNAP	For XA, SC, RDSR and Colored mf SC
				ANAP	For CT and eCT Images
Patient's Age	(0010,1010)	AUTO	Calculated from provided Birth Date	ALWAYS	

Attribute	Tag	Source	Value	Presence	Comments
Patient's Size	(0010,1020)	MWL/USER	Patient's height in centimeters	ANAP	
Patient's Weight	(0010,1030)	MWL/USER	Patient's weight in kilograms	ANAP	
Additional Patient History	(0010,21B0)	MWL	From MWL	ANAP	Only for XA, RDSR, SC and Colored mf SC
Admission ID	(0038,0010)	MWL	From MWL	ANAP	Only for CT and eCT Images.
Current Patient Location	(0038,0300)	MWL	From MWL	ANAP	Standard Extended Attribute.

Table 54: General Series and Enhanced Series Module

Attribute	Tag	Source	Value	Presence	Comments
Modality	(0008,0060)	AUTO	"XA" for X-Ray Angiographic, Secondary Capture Images "CT" for enhanced CT and CT Images "OT" for True Color Secondary mf SC Images	ALWAYS	
Series Instance UID	(0020,000E)	AUTO	Generated by device	ALWAYS	
Series Number	(0020,0011)	AUTO	Generated by device	ALWAYS	
Laterality	(0020,0060)	USER	"R", "L"	VNAP	
Series Date	(0008,0021)	AUTO		ALWAYS	
Series Time	(0008,0031)	AUTO		ALWAYS	
Performing Physician's Name	(0008,1050)	MWL/USER	From MWL or user input	ANAP	
Protocol Name	(0018,1030)	AUTO	Application Name XA Images	ALWAYS	For XA, eCT and CT
			Application Name, "Partial volume" or "Parallel ranges" for eCT and CT Images		
			"Exam Protocol (XA)"	ALWAYS	For SC Images
			-	Not Present	For Colored mf SC Images.
Series Description	(0008,103E)	USER/AUTO	Application Name for X-Ray Angiographic Images.	ALWAYS	For XA Images
			"3D Volume", "Partial volume" or "Parallel ranges"		For eCT and CT Images
			"Exam Protocol (XA)"		For SC Images
			-	Not Present	For Colored mf SC Images.

Attribute	Tag	Source	Value	Presence	Comments
Operators' name	(0008,1070)	USER	"Operator 1"\ "Operator 2" input	ANAP	
Referenced Performed Procedure Step	(0008,1111)	MPPS	Set when MPPS is configured	ANAP	
>Referenced SOP Class UID	(0008,1150)	MPPS	Set when MPPS is configured	ANAP	
>Referenced SOP Instance UID	(0008,1155)	MPPS	Set when MPPS is configured	ANAP	
Body Part Examined	(0018,0015)	USER		ANAP	For eCT and CT Images
		AUTO	-	Not Present	For XA, SC and Colored mf SC Images
Patient Position	(0018,5100)	AUTO	Positioning	ALWAYS	For XA 3D Scan, enhanced CT and CT
			-	Not Present	For Colored mf SC, SC and 2D XA Images.
View Position	(0018,5101)	AUTO	3D Scan only	VNAP	Standard Extended. Only for XA Images
			-	Not Present	For Colored mf SC, SC, enhanced CT and CT Images.
Request Attribute Sequence	(0040,0275)	MWL	From MWL	ANAP	
>Accession Number	(0008,0050)	MWL	From MWL	ANAP	
>Referenced Study Sequence	(0008,1110)	MWL	From MWL	ANAP	
>Study Instance UID	(0020,000D)	MWL	From MWL	ANAP	
>Requested Procedure Description	(0032,1060)	MWL	From MWL	ANAP	
>Requested Procedure Code Sequence	(0032,1064)	MWL	From MWL	ANAP	
>Scheduled Procedure Step Description	(0040,0007)	MWL	From MWL	ANAP	
>Scheduled Protocol Code Sequence	(0040,0008)	MWL	From MWL	ANAP	
>Scheduled Procedure Step ID	(0040,0009)	MWL	From MWL	ANAP	
>Requested Procedure ID	(0040,1001)	MWL/USER	From MWL or "Request ID" input	ANAP	

Attribute	Tag	Source	Value	Presence	Comments
Performed Procedure Step ID	(0040,0253)	AUTO	Supplied, even if MPPS SOP Class is not supported	ALWAYS	
Performed Procedure Step Start Date	(0040,0244)	AUTO	Supplied, even if MPPS SOP Class is not supported	ALWAYS	
Performed Procedure Step Start Time	(0040,0245)	AUTO	Supplied, even if MPPS SOP Class is not supported	ALWAYS	
Performed Procedure Step Description	(0040,0254)	AUTO	n.a.	VNAP	XA, SC and Colored mf SC Images
				ANAP	eCT, CT Images
Performed Protocol Code Sequence	(0040,0260)	MWL	Same as 0040,0275>0040,0008	ANAP	

Table 55: General Equipment Module

Attribute	Tag	Source	Value	Presence	Comments
Manufacturer	(0008,0070)	AUTO	"Siemens Healthineers"	ALWAYS	For XA, SC, RDSR and Colored mf SC
			"Siemens"		For eCT and CT
Institution Name	(0008,0080)	MWL / CONFIG / USER	From worklist, configuration or user input	VNAP	For XA, SC, RDSR and Colored mf SC
				ANAP	For eCT and CT
Institution Address	(0008,0081)	MWL/CONFIG	From worklist or configuration input	VNAP	For XA, SC, RDSR and Colored mf SC
				ANAP	For eCT and CT
Station Name	(0008,1010)	CONFIG	From Configuration hostname	ALWAYS	
Institutional Department Name	(0008,1040)	USER	"Institution Department Name" input	VNAP	For XA, SC, RDSR and Colored mf SC
				ANAP	For eCT and CT
Manufacturer's Model Name	(0008,1090)	AUTO	"Fluorospot Compact S1"	ALWAYS	For XA, eCT, CT, SC and Colored mf SC
			CIARTIC_Move		For RDSR
Device Serial Number	(0018,1000)	AUTO	<modality serial number>	ALWAYS	
Software Versions	(0018,1020)	AUTO	FLC Version \System Version	ALWAYS	
Date of Last Calibration	(0018,1200)	AUTO		ALWAYS	Only for XA
				ANAP	For eCT, CT, SC and Colored mf SC

Attribute	Tag	Source	Value	Presence	Comments
			-	Not present	RDSR
Time of Last Calibration	(0018,1201)	AUTO		ANAP	For CT and eCT
			-	Not present	For XA, RDSR, SC and Colored mf SC

Table 56: General Image Module

Attribute	Tag	Source	Value	Presence	Comments
Instance Number	(0020,0013)	AUTO	n.a.	ALWAYS	
Patient Orientation	(0020,0020)	AUTO	n.a.	EMPTY	For XA and SC Image
			n.a.	VNAP	For Colored mf SC
			According to position	ALWAYS	CT
Content Date	(0008,0023)	AUTO	n.a.	ALWAYS	
Content Time	(0008,0033)	AUTO	n.a.	ALWAYS	
Image Type	(0008,0008)	AUTO	n.a.	ALWAYS	Refer to 9.1.2 for used Image Type values
Acquisition Number	(0020,0012)	AUTO	Generated by device	ALWAYS	
Acquisition Date	(0008,0022)	AUTO	n.a.	ALWAYS	
Acquisition Datetime	(0008,002A)	AUTO	Datetime of Original Acquisition (X-Ray event)	ALWAYS	Only for CT
			n.a.	Not present	For XA, SC and Colored mf SC
Acquisition Time	(0008,0032)	AUTO	n.a.	ALWAYS	For CT
Derivation Description	(0008,2111)	AUTO	Notes about transformation steps	ANAP	For XA, SC and Colored mf SC
				Not present	For CT
Acquisition Device Processing Code	(0018,1401)	AUTO	"1" Advanced Spatial Noise Filtering is used	ALWAYS	Standard Extended. Only for XA
			"0" not used		
			n.a.	Not present	For CT, SC and colored mf SC
Positioner Type	(0018,1508)	AUTO	CARM	ANAP	Standard Extended. Only for XA
Images in Acquisition	(0020,1002)	AUTO	Generated	ALWAYS	Only for CT
			n.a.	Not present	XA, eCT, SC and colored mf SC
Image Comments	(0020,4000)	USER	If entered in UI	ANAP	For XA
			-	Not present	For SC, CT and Colored mf SC

Attribute	Tag	Source	Value	Presence	Comments
Burned In Annotation	(0028,0301)	AUTO	"NO"	ALWAYS	
Lossy Image Compression	(0028,2110)	AUTO	"00"	ALWAYS	
Irradiation Event UID	(0008,3010)	AUTO	Unique for one irradiation event	ALWAYS	XA, eCT, CT
				Not present	For SC and Colored mf SC I
Presentation LUT Shape	(2050,0020)	AUTO	IDENTITY	ALWAYS	For XA, SC, eCT and CT
			n.a.	Not present	For Colored mf SC

Table 57: Image Pixel Module

Attribute	Tag	Source	Value	Presence	Comments
Samples per Pixel	(0028,0002)	AUTO	"1"	ALWAYS	For XA, CT, eCT, SC
			"3"		For Colored mf SC
Photometric Interpretation	(0028,0004)	AUTO	"MONOCHROME2"	ALWAYS	For XA, CT, eCT, SC
			"RGB"		For Colored mf SC
Planar Configuration	(0028,0006)	AUTO		ANAP	Only for Colored mf SC
Rows	(0028,0010)	AUTO		ALWAYS	
Columns	(0028,0011)	AUTO		ALWAYS	
Pixel Aspect Ratio	(0028,0034)	AUTO	1/1	ANAP	Only for CT and eCT
Bits Allocated	(0028,0100)	AUTO	"8", "16"	ALWAYS	
Bits Stored	(0028,0101)	AUTO	"8", "12", "16"	ALWAYS	For XA, SC
			"16"	ALWAYS	For CT and eCT
			"8"	ALWAYS	For Colored mf SC
High Bit	(0028,0102)	AUTO	"7", "11", "15"	ALWAYS	
Pixel Representation	(0028,0103)	AUTO	0	ALWAYS	
Pixel Data	(7FE0,0010)	AUTO		ALWAYS	

Table 58: SOP Common Module

Attribute	Tag	Source	Value	Presence	Comments
SOP Class UID	(0008,0016)	AUTO	1.2.840.10008.5.1.4.1.1.12.1	ALWAYS	XA
			1.2.840.10008.5.1.4.1.1.2.1		eCT
			1.2.840.10008.5.1.4.1.1.2		CT

Attribute	Tag	Source	Value	Presence	Comments
			1.2.840.10008.5.1.4.1.1.7		SC
			1.2.840.10008.5.1.4.1.1.7.4		Colored mf SC
			1.2.840.10008.5.1.4.1.1.88.67		RDSR
SOP Instance UID	(0008,0018)	AUTO	Created. If different send options offered: same UID used.	ALWAYS	
Specific Character Set	(0008,0005)	MWL / CONFIG	From Configuration / RIS	ALWAYS	
Instance Creation Date	(0008,0012)	AUTO	<yyyymmdd>	ALWAYS	eCT, CT
			-	Not present	XA, SC, RDSR and Colored mf SC
Instance Creation Time	(0008,0013)	AUTO	n.a.	ALWAYS	eCT, CT
			-	Not present	XA, SC, RDSR and Colored mf SC
Instance Number	(0020,0013)	AUTO	Generated	ALWAYS	
Physical Detector Size	(0018,9429)	AUTO	Generated	ALWAYS	Standard Extension. Only for XA, CT and eCT
			-	Not present	For SC, RDSR and Colored mf SC

Table 59: Multi-frame Module

Attribute	Tag	Source	Value	Presence	Comments
Number of Frames	(0028,0008)	AUTO	n.a.	ALWAYS	For XA
			1		For Colored mf SC
Frame Increment Pointer	(0028,0009)	AUTO	(0018,1063) or (0018,1065) for variable frame rate	ANAP	For XA
				Not present	For Colored mf SC

Table 60: Frame of Reference Module

Attribute	Tag	Source	Value	Presence	Comments
Frame of Reference UID	(0020,0052)	AUTO	Generated	ALWAYS	For eCT and CT Images
Position Reference Indicator	(0020,1040)	AUTO	Zero length	EMPTY	For eCT and CT Images

Table 61: VOI LUT Module

Attribute	Tag	Source	Value	Presence	Comments
Window Center	(0028,1050)	AUTO / USER	<NAT value> 2 values if (0028,1040) = LOG	ALWAYS	XA
			Multiple values		CT
Window Width	(0028,1051)	AUTO / USER	<NAT value> 2 values if (0028,1040) = LOG	ALWAYS	XA
			Multiple values		CT
Window Center & Width Explanation	(0028,1055)	AUTO	Subtraction only	ANAP	XA
			Names of each window pair	ALWAYS	CT
VOI LUT Function	(0028,1056)	AUTO	"LINEAR"	ALWAYS	CT
			-	Not present	XA

Table 62: Overlay Plane Module

Attribute	Tag	Source	Value	Presence	Comments
Overlay Rows	(6000,0010)	AUTO	512	ALWAYS	Only for CT and eCT
			-	Not present	For XA, SC, RDSR and Colored mf SC
Overlay Columns	(6000,0011)	AUTO	512	ALWAYS	Only for CT and eCT
			-	Not present	For XA, SC, RDSR and Colored mf SC
Overlay Description	(6000,0022)	AUTO	"Non-ROI: Plain" or "Non-ROI: Segmented Navigation Markers"	ANAP	Only for CT and eCT
			-	Not present	For XA, SC, RDSR and Colored mf SC
Overlay Type	(6000,0040)	AUTO	R	ALWAYS	Only for CT and eCT
			-	Not present	For XA, SC, RDSR and Colored mf SC
Overlay Origin	(6000,0050)	AUTO	145\145	ALWAYS	Only for CT and eCT
			-	Not present	For XA, SC, RDSR and Colored mf SC
Overlay Bits Allocated	(6000,0100)	AUTO	1	ALWAYS	Only for CT and eCT
			-	Not present	For XA, SC, RDSR and Colored mf SC
Overlay Bit Position	(6000,0102)	AUTO	0	ALWAYS	Only for CT and eCT

Attribute	Tag	Source	Value	Presence	Comments
			-	Not present	For XA, SC, RDSR and Colored mf SC
Overlay Label	(6000,1500)	AUTO	"Full Reconstruction" -	ANAP	Only for CT and eCT
				Not present	For XA, SC, RDSR and Colored mf SC
Overlay Data	(6000,3000)	AUTO	Overlay data	ALWAYS	Only for CT and eCT
			-	Not present	For XA, SC, RDSR and Colored mf SC

9.1.1.8 X-Ray Angiographic Image Modules

Table 63: Contrast/Bolus Module

Attribute	Tag	Source	Value	Presence	Comments
Contrast/Bolus Agent	(0018,0010)	AUTO	"IODINE" or "CO2"	VNAP	

Table 64: Cine Module

Attribute	Tag	Source	Value	Presence	Comments
Frame Time	(0018,1063)	AUTO	(msec/frame) for fixed frame rates	ANAP	
Recommended Display Frame Rate	(0008,2144)	AUTO	(in f/s)	ANAP	
Cine Rate	(0018,0040)	AUTO	Acquired frame rate	ANAP	

Table 65: Frame Pointers Module

Attribute	Tag	Source	Value	Presence	Comments
Representative Frame Number	(0028,6010)	AUTO	For multiframe	ANAP	

Table 66: Mask Module

Attribute	Tag	Source	Value	Presence	Comments
Mask Subtraction Sequence	(0028,6100)	AUTO		ANAP	
>Mask Operation	(0028,6101)	AUTO	"AVG_SUB"	ANAP	

Attribute	Tag	Source	Value	Presence	Comments
>Mask Frame Numbers	(0028,6110)	AUTO	(only for AVG_SUB)	ALWAYS	
Recommended Viewing Mode	(0028,1090)	AUTO / USER	"SUB", "NAT"	ANAP	

Table 67: X-Ray Image Module

Attribute	Tag	Source	Value	Presence	Comments
Scan Options	(0018,0022)	AUTO	"ROTA", 3D Scan only.	ANAP	
Pixel Intensity Relationship	(0028,1040)	AUTO	"DISP", "LIN", "LOG"	ALWAYS	
Referenced Image Sequence	(0008,1140)	AUTO	From RIS	ANAP	
>Referenced SOP Class UID	(0008,1150)	AUTO	From RIS	ANAP	
>Referenced SOP Instance UID	(0008,1155)	AUTO	From RIS	ANAP	
Derivation Description	(0008,2111)	AUTO	Notes about transformation steps	ALWAYS	

Table 68: X-Ray Filtration Module

Attribute	Tag	Source	Value	Presence	Comments
Filter Type	(0018,1160)	AUTO	Defined Terms: NONE, CU_0.1_MM	ALWAYS	

Table 69: X-Ray Acquisition Module

Attribute	Tag	Source	Value	Presence	Comments
KVP	(0018,0060)	AUTO	<peak KV used> (KV). For a single image stored during Fluoro: value from whole Fluoro will be used.	VNAP	
Field of View Shape	(0018,1147)	AUTO	"RECTANGLE" for detector images	ANAP	
Field of View Dimension	(0018,1149)	AUTO	mm\mm	ANAP	
Radiation Setting	(0018,1155)	AUTO	"SC"	ALWAYS	
X-Ray Tube Current	(0018,1151)	AUTO	(mA)	VNAP	

Attribute	Tag	Source	Value	Presence	Comments
			For a single image stored during Fluoro: value from whole Fluoro will be used.		
Exposure	(0018,1152)	AUTO	(mAs) For a single image stored during Fluoro: value from whole Fluoro will be used.	VNAP	
X-Ray Tube Current in μ A	(0018,8151)	AUTO	(μ A)	VNAP	
Exposure Time	(0018,1150)	AUTO	Duration of x-Ray exposure (msec) For a single image stored during Fluoro: value from whole Fluoro will be used.	VNAP	
Exposure Time in μ S	(0018,8150)	AUTO	Duration of x-Ray exposure (μ sec)	VNAP	
Exposure in μ As	(0018,1153)	AUTO	(μ As) For a single image stored during Fluoro: value from whole Fluoro will be used.	VNAP	
Grid	(0018,1166)	AUTO	NONE FOCUSED	ALWAYS	
Average Pulse Width	(0018,1154)	AUTO	(msec) For a single image stored during Fluoro: value from whole Fluoro will be used.	VNAP	
Radiation Mode	(0018,115A)	AUTO	"CONTINUOUS", "PULSED"	ALWAYS	
Imager Pixel Spacing	(0018,1164)	AUTO	<row space, col space>(mm)	ALWAYS	
Pixel Spacing	(0028,0030)	AUTO	Calculated values	ALWAYS	
Image and Fluoroscopy Area Dose Product	(0018,115E)	AUTO	In dGy cm ²	VNAP	

Table 70: X-Ray Collimator Module

Attribute	Tag	Source	Value	Presence	Comments
Collimator Shape	(0018,1700)	AUTO	RECTANGULAR (== Back Projection Area)	ANAP	
Collimator Left Vertical Edge	(0018,1702)	AUTO	Column number left edge of Back Projection area	ANAP	
Collimator Right Vertical Edge	(0018,1704)	AUTO	Column number right edge of Back Projection area	ANAP	

Attribute	Tag	Source	Value	Presence	Comments
Collimator Upper Horizontal Edge	(0018,1706)	AUTO	Row number upper edge of Back Projection area	ANAP	
Collimator Lower Horizontal Edge	(0018,1708)	AUTO	Row number lower edge Projection area	ANAP	

Table 71: XA Positioner Module

Attribute	Tag	Source	Value	Presence	Comments
Distance Source to Patient	(0018,1111)	AUTO	(mm) Only if (0018,1110) is present - shall present if SOD or TOD is known, that means the image is calibrated	ANAP	
Distance Source to Detector	(0018,1110)	AUTO	(mm) SID	ALWAYS	
Estimated Radiographic Magnification Factor	(0018,1114)	AUTO	<Ratio of SID/SOD>	ANAP	
Positioner Motion	(0018,1500)	AUTO	"DYNAMIC", "STATIC"	ALWAYS	
Positioner Primary Angle	(0018,1510)	AUTO	Not present, if not configured. The definition of DICOM "with respect to the patient position" is fulfilled, if the C-arm is moved from the left towards the patient and the detector is positioned above the patient	ANAP	
Positioner Primary Angle	(0018,1510)	AUTO	Not present, if not configured. The definition of DICOM "with respect to the patient position" is fulfilled, if the C-arm is moved from the left towards the patient and the detector is positioned above the patient	ANAP	
Positioner Primary Angle Increment	(0018,1520)	AUTO	Generated	ANAP	
Positioner Secondary Angle Increment	(0018,1521)	AUTO	Generated	ANAP	

Table 72: DX Detector Module

Attribute	Tag	Source	Value	Presence	Comments
Plate ID	(0018,1004)	AUTO	Generated	ALWAYS	

Attribute	Tag	Source	Value	Presence	Comments
Detector Description	(0018,7006)	AUTO	Factory Serial Number	ALWAYS	
Detector ID	(0018,700A)	AUTO	Factory Serial Number	ALWAYS	
Sensitivity	(0018,6000)	AUTO	Internal value characterizing detector entrance dose	ALWAYS	
Detector Conditions Nominal Flag	(0018,7000)	AUTO	YES NO, if user was notified about possible image quality compromise	ALWAYS	
Detector Temperature	(0018,7001)	AUTO	<actual value>	ALWAYS	
Detector Type	(0018,7004)	AUTO	SCINTILLATOR	ALWAYS	
Date of Last Detector Calibration	(0018,700C)	AUTO	<yyyymmdd>	ALWAYS	
Time of Last Detector Calibration	(0018,700E)	AUTO	<hhmmss>	ALWAYS	
Field of View Origin	(0018,7030)	AUTO	<actual value>	ALWAYS	
Field of View Rotation	(0018,7032)	AUTO	"0","90","180" or "270"	ALWAYS	
Field of View Horizontal Flip	(0018,7034)	AUTO	"YES" or "NO"	ALWAYS	
Grid Focal Distance	(0018,704C)	AUTO		ANAP	Standard Extension

Table 73: Modality LUT Module

Attribute	Tag	Source	Value	Presence	Comments
Modality LUT Sequence	(0028,3000)	AUTO	(if [0028,1040] = LOG)	ANAP	
>LUT Descriptor	(0028,3002)	AUTO	<number of LUT entries>, <first pixel value mapped>, <Entry bits allocated>	ANAP	
>Modality LUT Type	(0028,3004)	AUTO	"US"	ANAP	
>LUT Data	(0028,3006)	AUTO	<array of data, accord. descriptor>	ANAP	

9.1.1.9 Enhanced Computer Tomography Image Modules

Table 74: Multi-Frame Functional Groups Module

Attribute	Tag	Source	Value	Presence	Comments
Instance Number	(0020,0013)	AUTO	1	ALWAYS	
Content Date	(0008,0023)	AUTO	Date	ALWAYS	
Content Time	(0008,0033)	AUTO	Time	ALWAYS	
Number of Frames	(0028,0008)	AUTO	n.a.	ALWAYS	
Representative Frame Number	(0028,6010)	AUTO/USER	Representative Frame Number	ALWAYS	
Shared Functional Groups Sequence	(5200,9229)	AUTO	n.a.	ALWAYS	
>Pixel Measures Sequence	(0028,9110)	AUTO	n.a.	ALWAYS	
>>Pixel Spacing	(0028,0030)	AUTO	mm\mm	ALWAYS	
>>Slice Thickness	(0018,0050)	AUTO	n.a.	ALWAYS	
>Plane Orientation Sequence	(0020,9116)	AUTO	n.a.	ALWAYS	
>>Image Orientation (Patient)	(0020,0037)	AUTO	n.a.	ALWAYS	
>Frame Anatomy Sequence	(0020,9071)	AUTO	n.a.	ALWAYS	
>>Frame Laterality	(0020,9072)	AUTO	n.a.	ALWAYS	
>Frame VOI LUT Sequence	(0028,9132)	AUTO		ALWAYS	
>>Window Center	(0028,1050)	AUTO	Multiple values possible	ALWAYS	
>>Window Width	(0028,1051)	AUTO	Multiple values possible	ALWAYS	
>>Window Center & Width Explanation	(0028,1055)	AUTO	Multiple values possible	ALWAYS	
>>VOI LUT Function	(0028,1056)	AUTO	"LINEAR"	ALWAYS	
>Irradiation Event Identification Sequence	(0018,9477)	AUTO		ALWAYS	
>>Irradiation Event UID	(0008,3010)	AUTO	Irradiation Event UID of projection images	ALWAYS	
>CT Geometry Sequence	(0018,9312)	AUTO		ALWAYS	
>>Distance Source to Detector	(0018,1110)	AUTO		ALWAYS	

Attribute	Tag	Source	Value	Presence	Comments
>>Distance Source to Data Collection Center	(0018,9335)	AUTO		ANAP	
>CT Reconstruction Sequence	(0018,9314)	AUTO		ALWAYS	
>>Reconstruction Algorithm	(0018,9315)	AUTO	FILTER_BACK_PROJ	ALWAYS	
>>Convolution Kernel	(0018,1210)	AUTO	A label describing the Convolution Kernel	ALWAYS	
>>Reconstruction Diameter	(0018,1100)	AUTO		ALWAYS	
>>Reconstruction Pixel Spacing	(0018,9322)	AUTO	mm\mm	ALWAYS	
>>Reconstruction Angle	(0018,9319)	AUTO		ALWAYS	
>>Image Filter	(0018,9320)	AUTO		ALWAYS	
>CT Exposure Sequence	(0018,9321)	AUTO		ALWAYS	
>>Exposure Time in ms	(0018,9328)	AUTO		ALWAYS	
>>X-Ray Tube Current in mA	(0018,9330)	AUTO		ALWAYS	
>>Exposure in mAs	(0018,9332)	AUTO		ALWAYS	
>CT X-Ray Details Sequence	(0018,9325)	AUTO		ALWAYS	
>>KVP	(0018,0060)	AUTO		ALWAYS	
>>Focal Spot(s)	(0018,1190)	AUTO		ALWAYS	
>>Filter Type	(0018,1160)	AUTO		ALWAYS	
>>Filter Material	(0018,7050)	AUTO		ALWAYS	
>Pixel Value Transformation Sequence	(0028,9145)	AUTO		ALWAYS	
>>Rescale Intercept	(0028,1052)	AUTO	-1.024000e+003	ALWAYS	
>>Rescale Slope	(0028,1053)	AUTO	+1.000000e+000	ALWAYS	
>>Rescale Type	(0028,1054)	AUTO	HU	ALWAYS	
Per frame Functional Groups Sequence	(5200,9230)	AUTO		ALWAYS	
> CT Image Frame Type Sequence	(0018,9329)	AUTO	n.a.	ALWAYS	

Attribute	Tag	Source	Value	Presence	Comments
>>Frame Type	(0008,9007)	AUTO	DERIVED\PRIMARY\VOLUME\NONE or DERIVED\SECONDARY\VOLUME\RANGES\PARALLEL or DERIVED\SECONDARY\VOLUME\RANGES\PARTIAL	ALWAYS	
>>Pixel Presentation	(0008,9205)	AUTO	MONOCHROME	ALWAYS	
>>Volumetric Properties	(0008,9206)	AUTO	VOLUME	ALWAYS	
>>Volume Based Calculation Technique	(0008,9207)	AUTO	NONE or MPR	ALWAYS	
>Frame Content Sequence	(0020,9111)	AUTO	n.a.	ALWAYS	
>> Stack ID	(0020,9056)	AUTO	1	ALWAYS	
>> In-Stack Position Number	(0020,9057)	AUTO	Starting with 1	ALWAYS	
>> Dimension Index Value	(0020,9157)	AUTO	1	ALWAYS	
> Plane Position Sequence	(0020,9113)	AUTO	n.a.	ALWAYS	
>> Image Position (Patient)	(0020,0032)	AUTO	Center of the patient coordinate system is in the isocenter	ALWAYS	
> Frame Acquisition Number	(0020,9156)	AUTO	For original volumes: Starting with 1 For partial volumes and parallel ranges: Starting with 0	ALWAYS	

Table 75: Multi-Frame Dimension Module

Attribute	Tag	Source	Value	Presence	Comments
Dimension Organization Sequence	(0020,9221)	AUTO		ALWAYS	
>Dimension Organization UID	(0020,9164)	AUTO	Generated	ALWAYS	
Dimension Index Sequence	(0020,9222)	AUTO		ALWAYS	

Attribute	Tag	Source	Value	Presence	Comments
>Dimension Index Pointer	(0020,9165)	AUTO	(0020,9056)	ALWAYS	
>Dimension Organization UID	(0020,9164)	AUTO	Generated Dimension Organization UID	ALWAYS	
>Functional Group Pointer	(0020,9167)	AUTO	(0020,9111)	ALWAYS	

Table 76: Enhanced CT Image Module

Attribute	Tag	Source	Value	Presence	Comments
Image Type	(0008,0008)	AUTO	Refer to 9.1.2 for used Image Type values	ALWAYS	
Pixel Presentation	(0008,9205)	AUTO	MONOCHROME	ALWAYS	
Volumetric Properties	(0008,9206)	AUTO	VOLUME	ALWAYS	
Volume Based Calculation Technique	(0008,9207)	AUTO	NONE or MPR	ALWAYS	
Acquisition Number	(0020,0012)	AUTO	Generated	ALWAYS	
Acquisition DateTime	(0008,002A)	AUTO	Date and Time of Original Acquisition (X-Ray event)	ALWAYS	
Content Qualification	(0018,9004)	AUTO	"PRODUCT"	ALWAYS	
Burned In Annotation	(0028,0301)	AUTO	"NO"	ALWAYS	
Lossy Image Compression	(0028,2110)	AUTO	00	ALWAYS	
Presentation LUT Shape	(2050,0020)	AUTO	IDENTITY	ALWAYS	

Table 77: Acquisition Context Module

Attribute	Tag	Source	Value	Presence	Comments
Acquisition Context Sequence	(0040,0555)	AUTO	-	EMPTY	

Table 78: Multi-frame Overlay Module

Attribute	Tag	Source	Value	Presence	Comments
Number of Frames in Overlay	(6000,0015)	AUTO	512	ALWAYS	
Image Frame Origin	(6000,0051)	AUTO	1	ANAP	

9.1.1.10 Computer Tomography Image Modules**Table 79: Image Plane Module**

Attribute	Tag	Source	Value	Presence	Comments
Pixel Spacing	(0028,0030)	AUTO	Calculated values	ANAP	
Image Orientation (Patient)	(0020,0037)	AUTO	Generated	ALWAYS	
Image Position (Patient)	(0020,0032)	AUTO	Generated	ALWAYS	
Slice Thickness	(0018,0050)	AUTO	Slice Thickness	ALWAYS	

Table 80: CT Image Module

Attribute	Tag	Source	Value	Presence	Comments
Rescale Intercept	(0028,1052)	AUTO	-1.024000e+003	ALWAYS	
Rescale Slope	(0028,1053)	AUTO	+1.000000e+000	ALWAYS	
Rescale Type	(0028,1054)	AUTO	HU	ALWAYS	
KVP	(0018,0060)	AUTO	<peak KV used> (KV)	ALWAYS	
Distance Source to Detector	(0018,1110)	AUTO	(mm) SID	ALWAYS	
Distance Source to Patient	(0018,1111)	AUTO	(mm) Only if (0018,1110) is present - shall present if SOD or TOD is known, that means the image is calibrated	ANAP	
X-Ray Tube Current	(0018,1151)	AUTO	(mA)	ALWAYS	
Exposure	(0018,1152)	AUTO	(mAs)	ALWAYS	
Exposure in μ As	(0018,1153)	AUTO	(μ As)	ALWAYS	

9.1.1.11 (Colored Multi-frame) Secondary Capture Image Modules

Table 81: SC Equipment Module

Attribute	Tag	Source	Value	Presence	Comments
Conversion Type	(0008,0064)	AUTO	WSD	ALWAYS	For Colored mf SC Images
			DI		For SC Images

9.1.1.12 X-Ray Radiation Dose SR Modules

Table 82: SR Document Series Module

Attribute	Tag	Source	Value	Presence	Comments
Modality	(0008,0060)	AUTO	"SR"	ALWAYS	
Series Instance UID	(0020,000E)	AUTO	Generated by device	ALWAYS	
Series Number	(0020,0011)	AUTO	Count of Dose SR object within study	ALWAYS	
Series Date	(0008,0021)	AUTO	Current date	ALWAYS	
Series Time	(0008,0031)	AUTO	Current time	ALWAYS	
Series Description	(0008,103E)	AUTO	"Radiation Dose Information"	ALWAYS	
Referenced Performed Procedure Step Sequence	(0008,1111)	AUTO	Generated by device	ALWAYS	
>Referenced SOP Class UID	(0008,1150)	AUTO	Generated by device	ALWAYS	
>Referenced SOP Instance UID	(0008,1155)	AUTO	Generated by device	ALWAYS	

Table 83: SR Document General Module

Attribute	Tag	Source	Value	Presence	Comments
Instance Number	(0020,0013)	AUTO	"1"	ALWAYS	
Completion Flag	(0040,A491)	AUTO	"COMPLETE"	ALWAYS	
Verification Flag	(0040,A493)	AUTO	"UNVERIFIED"	ALWAYS	
Content Date	(0008,0023)	AUTO	n.a.	ALWAYS	
Content Time	(0008,0033)	AUTO	n.a.	ALWAYS	
Performed Procedure Code Sequence	(0040,A372)	AUTO	n.a.	EMPTY	

Table 84: SR Document Content Module

Attribute	Tag	Source	Value	Presence	Comments
Value Type	(0040,A040)	AUTO	"CONTAINER"	ALWAYS	
Concept Name Code Sequence	(0040,A043)	AUTO	n.a.	ALWAYS	
>Code Value	(0008,0100)	AUTO	"113701"	ALWAYS	
>Coding Scheme Designator	(0008,0102)	AUTO	"DCM"	ALWAYS	
>Code Meaning	(0008,0104)	AUTO	"X-Ray Radiation Dose Report"	ALWAYS	
Continuity of Content	(0040,A050)	AUTO	"SEPARATE"	ALWAYS	
Content Template Sequence	(0040,A504)	AUTO	n.a.	ALWAYS	
> Mapping Resource	(0008,0105)	AUTO	"DCMR"	ALWAYS	
>Template Identifier	(0040,DB00)	AUTO	"10001"	ALWAYS	
Content Sequence	(0040,A730)	AUTO		ALWAYS	
>Include content data according to TID 10001		AUTO		ALWAYS	

9.1.1.13 Private Modules

Table 85: Private Data Element Dictionary - SIEMENS_FLCOMPACT_VA01A_PROC

Attribute	Tag	Source	Value	Presence	Comments
Private Creator	(0017,00xx)	AUTO	SIEMENS_FLCOMPACT_VA01A_PROC	ANAP	
Blackening Correction	(0017,xx0A)	AUTO	Internal value	ANAP	
Dose Level	(0017,xx0B)	AUTO	Internal value	ANAP	
SDM	(0017,xx0C)	AUTO	Internal value	ANAP	
Frame rate	(0017,xx0D)	AUTO	Internal value	ANAP	
Characteristic Curve	(0017,xx0E)	AUTO	Internal value	ANAP	
Copper Filter	(0017,xx0F)	AUTO	Internal value	ANAP	
Skin Dose	(0017,xx10)	AUTO	Internal value	ANAP	
Focus	(0017,xx11)	AUTO	Internal value	ANAP	
Windowing Presets	(0017,xx12)	AUTO	Internal value	ANAP	

Attribute	Tag	Source	Value	Presence	Comments
Windowing Presets Sub/Road	(0017,xx13)	AUTO	Internal value	ANAP	
Bone Level (white/black)	(0017,xx16)	AUTO	Internal value	ANAP	
Contrast	(0017,xx17)	AUTO	Internal value	ANAP	
Brightness	(0017,xx18)	AUTO	Internal value	ANAP	
Shutter X	(0017,xx19)	AUTO	Internal value	ANAP	
Shutter Y	(0017,xx1A)	AUTO	Internal value	ANAP	
Flip H	(0017,xx1B)	AUTO	Internal value	ANAP	
Flip V	(0017,xx1C)	AUTO	Internal value	ANAP	
Zoom (On / Off)	(0017,xx1E)	AUTO	Internal value	ANAP	
Pan X	(0017,xx1F)	AUTO	Internal value	ANAP	
Pan Y	(0017,xx20)	AUTO	Internal value	ANAP	
Harmonization	(0017,xx21)	AUTO	Internal value	ANAP	
DSA Mask index	(0017,xx22)	AUTO	Internal value	ANAP	
DSA display sub/nat	(0017,xx23)	AUTO	Internal value	ANAP	
DSA Contrast	(0017,xx24)	AUTO	Internal value	ANAP	
DSA Brightness	(0017,xx25)	AUTO	Internal value	ANAP	
Subtracted Edge Enhancement	(0017,xx26)	AUTO	Internal value	ANAP	
Landmark	(0017,xx27)	AUTO	Internal value	ANAP	
Pixelshift X	(0017,xx28)	AUTO	Internal value	ANAP	
Pixelshift Y	(0017,xx29)	AUTO	Internal value	ANAP	
Series number	(0017,xx48)	AUTO	Internal value	ANAP	
Label	(0017,xx49)	AUTO	Internal value	ANAP	
Series / Single flag	(0017,xx4D)	AUTO	Internal value	ANAP	
Series date	(0017,xx4E)	AUTO	Internal value	ANAP	
Series time	(0017,xx4F)	AUTO	Internal value	ANAP	
Image type	(0017,xx50)	AUTO	Internal value	ANAP	
Edge Enhancement Presets	(0017,xx51)	AUTO	Internal value	ANAP	
Edge Enhancement Kernel Native	(0017,xx52)	AUTO	Internal value	ANAP	
Edge Enhancement Kernel Subtracted	(0017,xx53)	AUTO	Internal value	ANAP	

Attribute	Tag	Source	Value	Presence	Comments
Harmonization Kernel	(0017,xx54)	AUTO	Internal value	ANAP	
DSA flag	(0017,xx55)	AUTO	Internal value	ANAP	
Native Edge Enhancement Percent Gain Acq	(0017,xx64)	AUTO	Internal value	ANAP	
Bone level (white/black)	(0017,xx66)	AUTO	Internal value	ANAP	
Contrast	(0017,xx67)	AUTO	Internal value	ANAP	
Brightness	(0017,xx68)	AUTO	Internal value	ANAP	
Harmonization Acquisition	(0017,xx85)	AUTO	Internal value	ANAP	
DSA Mask index	(0017,xx86)	AUTO	Internal value	ANAP	
DSA display sub/nat	(0017,xx87)	AUTO	Internal value	ANAP	
DSA Contrast	(0017,xx88)	AUTO	Internal value	ANAP	
DSA Brightness	(0017,xx89)	AUTO	Internal value	ANAP	
Subtracted Edge Enhancement	(0017,xx8A)	AUTO	Internal value	ANAP	
Landmark	(0017,xx8B)	AUTO	Internal value	ANAP	
Pixelshift X Acquisition	(0017,xx8C)	AUTO	Internal value	ANAP	
Pixelshift Y Acquisition	(0017,xx8D)	AUTO	Internal value	ANAP	
Shutter X	(0017,xx8E)	AUTO	Internal value	ANAP	
Shutter Y	(0017,xx8F)	AUTO	Internal value	ANAP	
FD config: FlipV	(0017,xx90)	AUTO	Internal value	ANAP	
FD config: FlipH	(0017,xx91)	AUTO	Internal value	ANAP	
FD config: Rotation	(0017,xx92)	AUTO	Internal value	ANAP	
FD config: Orientation	(0017,xx93)	AUTO	Internal value	ANAP	
Laterality	(0017,xxA0)	AUTO	Internal value	ANAP	
R/L label	(0017,xxA1)	AUTO	R/L Label flag	ANAP	
X,Y value respective to cropped	(0017,xxA2)	AUTO	X,Y value respective to cropped image	ANAP	
System type	(0017,xxAA)	AUTO	Internal value	ANAP	

Attribute	Tag	Source	Value	Presence	Comments
Detector Calibration Temperature	(0017,xxB0)	AUTO	temperature of the detector in the moment of calibration in degree Celsius	ANAP	
Organ Name	(0017,xxBF)	AUTO	name of the performed OGP	ANAP	
Exam Name	(0017,xxC0)	AUTO	name of the performed Exam	ANAP	
Anatomical measurement	(0017,xxC1)	AUTO	flag, if "anatomical measurement" was checked	ANAP	
Data Model	(0017,xxC2)	AUTO	0 for 1 image per series 1 for n images per series	ANAP	
RIS Name	(0017,xxC4)	AUTO	RIS name of the used exam	ANAP	
Metal Correction	(0017,xxE0)	AUTO	0=No, 1= Yes	ANAP	
K-Factor	(0017,xxE1)	AUTO	Internal value	ANAP	

Table 86: Private Data Element Dictionary – Siemens: Thorax/Multix FD Lab Settings

Attribute	Tag	Source	Value	Presence	Comments
Private Creator	(0019,00xx)	AUTO	Siemens: Thorax/Multix FD Lab Settings	ANAP	Private Owner Code
Table Object Distance	(0019,xx06)	AUTO	Internal value	ANAP	
Table Detector Distance	(0019,xx07)	AUTO	Internal value	ANAP	
Ortho Step Distance	(0019,xx08)	AUTO	Internal value	ANAP	
Asymmetric Collimation	(0019,xx09)	AUTO	Internal value	ANAP	

Table 87: Private Data Element Dictionary – Siemens: Thorax/Multix FD Post Processing

Attribute	Tag	Source	Value	Presence	Comments
Private Creator	(0021,00xx)	AUTO	Siemens: Thorax/Multix FD Post Processing	ANAP	Private Owner Code
Auto Window Flag	(0021,xx08)	AUTO	Internal value	ANAP	
Auto Window Center	(0021,xx09)	AUTO	Internal value	ANAP	
Auto Window Width	(0021,xx0A)	AUTO	Internal value	ANAP	

Attribute	Tag	Source	Value	Presence	Comments
Filter ID	(0021,xx0B)	AUTO	Internal value	ANAP	
Internal Value	(0021,xx13)	AUTO	Internal value	ANAP	
Anatomic Correct View	(0021,xx14)	AUTO	Internal value	ANAP	
Auto Window Shift	(0021,xx15)	AUTO	Internal value	ANAP	
Auto Window Expansion	(0021,xx16)	AUTO	Internal value	ANAP	
System Type	(0021,xx17)	AUTO	Internal value	ANAP	
Detector Type	(0021,xx18)	AUTO	Internal value	ANAP	
Anatomic Sort Number	(0021,xx30)	AUTO	From organ program	ANAP	
Acquisition Sort Number	(0021,xx31)	AUTO	Internal value	ANAP	

Table 88: Private Data Element Dictionary - VDM_VA30

Attribute	Tag	Source	Value	Presence	Comments
Private Creator	(0023,00xx)	AUTO	VDM_VA30	ANAP	Private Owner Code
Slice Thickness Factors	(0023,xx00)	CONFIG	In cm Dependent on acquisition type (card, angio)	ANAP	Slice Thickness Factors

Table 89: Private Data Element Dictionary – Siemens: Thorax/Multix FD Raw Image Settings

Attribute	Tag	Source	Value	Presence	Comments
Private Creator	(0025,00xx)	AUTO	Siemens: Thorax/Multix FD Raw Image Settings	ANAP	Private Owner Code
Raw Image Amplification	(0025,xx00)	AUTO	n.a.	ANAP	
Harmonization Kernel	(0025,xx0C)	AUTO	n.a.	ANAP	
Harmonization Gain	(0025,xx0D)	AUTO	n.a.	ANAP	
Edge Enhancement Kernel	(0025,xx0E)	AUTO	n.a.	ANAP	
Edge Enhancement Gain	(0025,xx0F)	AUTO	n.a.	ANAP	

Attribute	Tag	Source	Value	Presence	Comments
Internal Value	(0025,xx10)	AUTO	n.a.	ANAP	
Auto Gain	(0025,xx18)	AUTO	n.a.	ANAP	
Ortho Subsampling	(0025,xx19)	AUTO	n.a.	ANAP	
Image Crop Upper Left	(0025,xx1A)	AUTO	n.a.	ANAP	
Image Crop Upper Right	(0025,xx1B)	AUTO	n.a.	ANAP	
Image Crop Lower Left	(0025,xx1C)	AUTO	n.a.	ANAP	
Image Crop Lower Right	(0025,xx1D)	AUTO	n.a.	ANAP	
Manual Cropping	(0025,xx30)	AUTO	0 = NO 1 = YES	ALWAYS	
Gamma LUT Parameter 1	(0025,xx31)	AUTO	n.a.	ANAP	
Gamma LUT Parameter 2	(0025,xx32)	AUTO	n.a.	ANAP	
Gamma LUT Parameter 3	(0025,xx33)	AUTO	n.a.	ANAP	
Gamma LUT Parameter 4	(0025,xx34)	AUTO	n.a.	ANAP	
Gamma LUT Name	(0025,xx35)	AUTO	n.a.	ANAP	
Physical Exi	(0025,xx36)	AUTO	n.a.	ANAP	
Clinical Exi	(0025,xx37)	AUTO	n.a.	ANAP	

Table 90: Private Data Element Dictionary - ISOC 3D NAVIGATIONMATRIX.R. 2.0

Attribute	Tag	Source	Value	Presence	Comments
Private Creator	(0029,00xx)	AUTO	ISOC 3D NAVIGATIONMATRIX.R. 2.0	ANAP	Private Owner Code
NavConfigUID	(0029,xx00)	AUTO	n.a.	ANAP	
ISOCID	(0029,xx01)	AUTO	n.a.	ANAP	
ScanID	(0029,xx02)	AUTO	n.a.	ANAP	
CalibrationID	(0029,xx03)	AUTO	n.a.	ANAP	
Transformation Matrix MA	(0029,xx04)	AUTO	n.a.	ANAP	

Attribute	Tag	Source	Value	Presence	Comments
MA Filename	(0029,xx05)	AUTO	n.a.	ANAP	
No. of projections requested	(0029,xx06)	AUTO	n.a.	ANAP	
No. of Projections done	(0029,xx07)	AUTO	n.a.	ANAP	
SideID	(0029,xx08)	AUTO	n.a.	ANAP	
NavSenderID	(0029,xx09)	AUTO	n.a.	ANAP	
NavConfigName	(0029,xx10)	AUTO	n.a.	ANAP	

9.1.2 Image Type Values

Additional values for the image type attribute are used to designate the purpose of the SOP instance created by the CIARTIC Family system. Please see the following table for details.

Table 91: Image Type Extensions

Type of Scene/Image	Image Type
Fluoro Image Single	ORIGINAL\PRIMARY\SINGLE PLANE\FLUORO\SINGLE
Fluoro Image Scene	ORIGINAL\PRIMARY\SINGLE PLANE\FLUORO\LOOP
SUB Single Image	ORIGINAL\PRIMARY\SINGLE PLANE\STORE MONITOR\SUB
SUB Peak Opacification	ORIGINAL\PRIMARY\SINGLE PLANE\STORE MONITOR\PEAKOP
Standard SUB Series	ORIGINAL\PRIMARY\SINGLE PLANE\FLUORO\SUB
Fluoro Image Last Image Hold	ORIGINAL\PRIMARY\SINGLE PLANE\FLUORO\LIH
Roadmap Single Image	ORIGINAL\PRIMARY\SINGLE PLANE\ROADMAP\SINGLE
Standard Roadmap Series	ORIGINAL\PRIMARY\SINGLE PLANE\ROADMAP\LOOP
Standard DR	ORIGINAL\PRIMARY\SINGLE PLANE\FLUORO\DR
Standard DCM Series	ORIGINAL\PRIMARY\SINGLE PLANE\FLUORO\DCM
Standard DCM Single Image	DERIVED\SECONDARY\SINGLE PLANE\FLUORO\STORE MONITOR\DCM
3D Projection Image	ORIGINAL\PRIMARY\SINGLE PLANE\3DSCAN\3DCARM
3D reconstructed Volume	DERIVED\PRIMARY\VOLUME\NONE\3DCARM
3D Parallel Ranges	DERIVED\SECONDARY\VOLUME\RANGES\PARALLEL
3D Partial Volume	DERIVED\SECONDARY\VOLUME\RANGES\PARTIAL
Dose Report as Secondary Capture / Exam Protocol	DERIVED\SECONDARY\SINGLE PLANE\EXAMPROTOCOL

9.1.3 Usage of Attributes from received IODs

N/A

9.1.4 Attribute mapping

For details regarding the mapping between Modality Worklist and created object, refer to Section 9.1.1 Created SOP Instances

For the mapping between Modality Worklist and MPPS, refer to section 4.2.6 Modality Performed Procedure Step AE Specification

9.1.5 Coerced / Modified fields

N/A

9.2 Data Dictionary of Private Attributes

Table 92 lists private attributes created which may be included in instances generated by the CIARTIC Family. These private attributes may be deprecated or replaced with standard attributes in the future.

Table 92: Private Data Element Dictionary

DICOM Tag	Name	VR
(0017,SIEMENS_FLCOMPACT_VA01A_PROC,0A)	Blackening Correction	SS
(0017,SIEMENS_FLCOMPACT_VA01A_PROC,0B)	Dose Level	SS
(0017,SIEMENS_FLCOMPACT_VA01A_PROC,0C)	SDM	SS
(0017,SIEMENS_FLCOMPACT_VA01A_PROC,0D)	Frame rate	FL
(0017,SIEMENS_FLCOMPACT_VA01A_PROC,0E)	Characteristic Curve	LO
(0017,SIEMENS_FLCOMPACT_VA01A_PROC,0F)	Copper Filter	LO
(0017,SIEMENS_FLCOMPACT_VA01A_PROC,10)	Skin Dose	SS
(0017,SIEMENS_FLCOMPACT_VA01A_PROC,11)	Focus	SS
(0017,SIEMENS_FLCOMPACT_VA01A_PROC,16)	Bone Level (white/black)	US
(0017,SIEMENS_FLCOMPACT_VA01A_PROC,17)	Contrast	US
(0017,SIEMENS_FLCOMPACT_VA01A_PROC,18)	Brightness	US
(0017,SIEMENS_FLCOMPACT_VA01A_PROC,19)	Shutter X	US
(0017,SIEMENS_FLCOMPACT_VA01A_PROC,1A)	Shutter Y	US
(0017,SIEMENS_FLCOMPACT_VA01A_PROC,1B)	Flip H	US
(0017,SIEMENS_FLCOMPACT_VA01A_PROC,1C)	Flip V	US
(0017,SIEMENS_FLCOMPACT_VA01A_PROC,1E)	Zoom (On / Off)	US
(0017,SIEMENS_FLCOMPACT_VA01A_PROC,1F)	Pan X	SS
(0017,SIEMENS_FLCOMPACT_VA01A_PROC,20)	Pan Y	SS
(0017,SIEMENS_FLCOMPACT_VA01A_PROC,21)	Harmonization	US
(0017,SIEMENS_FLCOMPACT_VA01A_PROC,22)	DSA Mask index	US
(0017,SIEMENS_FLCOMPACT_VA01A_PROC,23)	DSA display sub/nat	US
(0017,SIEMENS_FLCOMPACT_VA01A_PROC,24)	DSA Contrast	US
(0017,SIEMENS_FLCOMPACT_VA01A_PROC,25)	DSA Brightness	US
(0017,SIEMENS_FLCOMPACT_VA01A_PROC,26)	Subtracted Edge Enhancement	US
(0017,SIEMENS_FLCOMPACT_VA01A_PROC,27)	Landmark	US
(0017,SIEMENS_FLCOMPACT_VA01A_PROC,28)	Pixelshift X	FL
(0017,SIEMENS_FLCOMPACT_VA01A_PROC,29)	Pixelshift Y	FL
(0017,SIEMENS_FLCOMPACT_VA01A_PROC,48)	Series number	SS
(0017,SIEMENS_FLCOMPACT_VA01A_PROC,49)	Label	SS
(0017,SIEMENS_FLCOMPACT_VA01A_PROC,4D)	Series / Single flag	SS

DICOM Tag	Name	VR
(0017,SIEMENS_FLCOMPACT_VA01A_PROC,4E)	Series date	LO
(0017,SIEMENS_FLCOMPACT_VA01A_PROC,4F)	Series time	LO
(0017,SIEMENS_FLCOMPACT_VA01A_PROC,50)	Image type	SS
(0017,SIEMENS_FLCOMPACT_VA01A_PROC,52)	Edge Enhancement Kernel Native	SS
(0017,SIEMENS_FLCOMPACT_VA01A_PROC,53)	Edge Enhancement Kernel Subtracted	SS
(0017,SIEMENS_FLCOMPACT_VA01A_PROC,54)	Harmonization Kernel	SS
(0017,SIEMENS_FLCOMPACT_VA01A_PROC,55)	DSA flag	SS
(0017,SIEMENS_FLCOMPACT_VA01A_PROC,64)	Native Edge Enhancement Percent Gain Acq	FL
(0017,SIEMENS_FLCOMPACT_VA01A_PROC,66)	Bone level (white/black)	US
(0017,SIEMENS_FLCOMPACT_VA01A_PROC,67)	Contrast	US
(0017,SIEMENS_FLCOMPACT_VA01A_PROC,68)	Brightness	US
(0017,SIEMENS_FLCOMPACT_VA01A_PROC,85)	Harmonization Acquisition	US
(0017,SIEMENS_FLCOMPACT_VA01A_PROC,86)	DSA Mask index	US
(0017,SIEMENS_FLCOMPACT_VA01A_PROC,87)	DSA display sub/nat	US
(0017,SIEMENS_FLCOMPACT_VA01A_PROC,88)	DSA Contrast	US
(0017,SIEMENS_FLCOMPACT_VA01A_PROC,89)	DSA Brightness	US
(0017,SIEMENS_FLCOMPACT_VA01A_PROC,8A)	Subtracted Edge Enhancement	US
(0017,SIEMENS_FLCOMPACT_VA01A_PROC,8B)	Landmark	US
(0017,SIEMENS_FLCOMPACT_VA01A_PROC,8C)	Pixelshift X Acquisition	FL
(0017,SIEMENS_FLCOMPACT_VA01A_PROC,8D)	Pixelshift Y Acquisition	FL
(0017,SIEMENS_FLCOMPACT_VA01A_PROC,8E)	Shutter X	US
(0017,SIEMENS_FLCOMPACT_VA01A_PROC,8F)	Shutter Y	US
(0017,SIEMENS_FLCOMPACT_VA01A_PROC,90)	FD config: FlipV	US
(0017,SIEMENS_FLCOMPACT_VA01A_PROC,91)	FD config: FlipH	US
(0017,SIEMENS_FLCOMPACT_VA01A_PROC,92)	FD config: Rotation	US
(0017,SIEMENS_FLCOMPACT_VA01A_PROC,93)	FD config: Orientation	US
(0017,SIEMENS_FLCOMPACT_VA01A_PROC,A0)	Laterality	US
(0017,SIEMENS_FLCOMPACT_VA01A_PROC,A1)	R/L label	US
(0017,SIEMENS_FLCOMPACT_VA01A_PROC,A2)	X,Y value respective to cropped	US
(0017,SIEMENS_FLCOMPACT_VA01A_PROC,AA)	System type	US
(0017,SIEMENS_FLCOMPACT_VA01A_PROC,AB)	Ortho Technique	US
(0017,SIEMENS_FLCOMPACT_VA01A_PROC,B0)	Detector calibration temperature	DS
(0017,SIEMENS_FLCOMPACT_VA01A_PROC,BF)	name of the performed OGP	LO
(0017,SIEMENS_FLCOMPACT_VA01A_PROC,C0)	name of the performed Exam	LO
(0017,SIEMENS_FLCOMPACT_VA01A_PROC,C1)	Anatomical measurement	US
(0017,SIEMENS_FLCOMPACT_VA01A_PROC,C2)	Data Model	US

DICOM Tag	Name	VR
(0017,SIEMENS_FLCOMPACT_VA01A_PROC,C3)	Mark number	US
(0017,SIEMENS_FLCOMPACT_VA01A_PROC,C4)	RIS name	US
(0017,SIEMENS_FLCOMPACT_VA01A_PROC,D0)	Acc. Fluoro time	US
(0017,SIEMENS_FLCOMPACT_VA01A_PROC,D1)	Acc. Dose Area Product	LO
(0017,SIEMENS_FLCOMPACT_VA01A_PROC,D2)	Acc. Skin Dose	LO
(0017,SIEMENS_FLCOMPACT_VA01A_PROC,E0)	Metal Correction	US
(0017,SIEMENS_FLCOMPACT_VA01A_PROC,E1)	K-Factor	US
(0017,SIEMENS_FLCOMPACT_VA01A_PROC,F0)	Scan Arc	DS
(0017,SIEMENS_FLCOMPACT_VA01A_PROC,F1)	Scan Start Position	DS
(0017,SIEMENS_FLCOMPACT_VA01A_PROC,F2)	Scan End Position	DS
(0017,SIEMENS_FLCOMPACT_VA01A_PROC,F3)	Primary Scan Angles	DS
(0017,SIEMENS_FLCOMPACT_VA01A_PROC,F4)	Secondary Scan Angles	DS
(0017,SIEMENS_FLCOMPACT_VA01A_PROC,F5)	Scan Interruptions	IS
(0017,SIEMENS_FLCOMPACT_VA01A_PROC,F6)	P-Matrix	OB
(0017,SIEMENS_FLCOMPACT_VA01A_PROC,F7)	Reconstruction Filter Name	CS
(0017,SIEMENS_FLCOMPACT_VA01A_PROC,F8)	Number of Voxels	IS
(0017,SIEMENS_FLCOMPACT_VA01A_PROC,F9)	Size of Voxel	DS
(0017,SIEMENS_FLCOMPACT_VA01A_PROC,FA)	Center Offset Values	DS
(0017,SIEMENS_FLCOMPACT_VA01A_PROC,FB)	X-Ray Quadruples	SL
(0019,Thorax/Multix FD Lab Settings,06)	Table Object Distance	FD
(0019,Thorax/Multix FD Lab Settings,07)	Table Detector Distance	FD
(0019,Thorax/Multix FD Lab Settings,08)	Ortho Step Distance	US
(0019,Thorax/Multix FD Lab Settings,09)	Asymmetric Collimation	LO
(0021,Siemens: Thorax/Multix FD Post Processing,08)	Auto Window Flag	SS
(0021,Siemens: Thorax/Multix FD Post Processing,09)	Auto Window Center	SS
(0021,Siemens: Thorax/Multix FD Post Processing,0A)	Auto Window Width	SS
(0021,Siemens: Thorax/Multix FD Post Processing,0B)	Filter ID	FL
(0021,Siemens: Thorax/Multix FD Post Processing,13)	Internal Value	LO
(0021,Siemens: Thorax/Multix FD Post Processing,14)	Anatomic Correct View	LO
(0021,Siemens: Thorax/Multix FD Post Processing,15)	Auto Window Shift	SS
(0021,Siemens: Thorax/Multix FD Post Processing,16)	Auto Window Expansion	SS
(0021,Siemens: Thorax/Multix FD Post Processing,17)	System Type	US
(0021,Siemens: Thorax/Multix FD Post Processing,18)	Detector Type	US
(0021,Siemens: Thorax/Multix FD Post Processing,30)	Anatomic Sort Number	US
(0021,Siemens: Thorax/Multix FD Post Processing,31)	Acquisition Sort Number	US
(0023,VDM_VA30,00)	Slice Thickness Factors	FL

DICOM Tag	Name	VR
(0025,Siemens: Thorax/Multix FD Raw Image Settings,00)	Raw Image Amplification	SS
(0025,Siemens: Thorax/Multix FD Raw Image Settings,0C)	Harmonization Kernel	SS
(0025,Siemens: Thorax/Multix FD Raw Image Settings,0D)	Harmonization Gain	FL
(0025,Siemens: Thorax/Multix FD Raw Image Settings,0E)	Edge Enhancement Kernel	SS
(0025,Siemens: Thorax/Multix FD Raw Image Settings,0F)	Edge Enhancement Gain	FL
(0025,Siemens: Thorax/Multix FD Raw Image Settings,10)	Internal Value	LT
(0025,Siemens: Thorax/Multix FD Raw Image Settings,18)	Auto Gain	US
(0025,Siemens: Thorax/Multix FD Raw Image Settings,19)	Ortho Subsampling	US
(0025,Siemens: Thorax/Multix FD Raw Image Settings,1A)	Image Crop Upper Left	US
(0025,Siemens: Thorax/Multix FD Raw Image Settings,1B)	Image Crop Upper Right	US
(0025,Siemens: Thorax/Multix FD Raw Image Settings,1C)	Image Crop Lower Left	US
(0025,Siemens: Thorax/Multix FD Raw Image Settings,1D)	Image Crop Lower Right	US
(0025,Siemens: Thorax/Multix FD Raw Image Settings,30)	Manual Cropping	US
(0025,Siemens: Thorax/Multix FD Raw Image Settings,31)	Gamma LUT Parameter 1	SS
(0025,Siemens: Thorax/Multix FD Raw Image Settings,32)	Gamma LUT Parameter 2	DS
(0025,Siemens: Thorax/Multix FD Raw Image Settings,33)	Gamma LUT Parameter 3	SS
(0025,Siemens: Thorax/Multix FD Raw Image Settings,34)	Gamma LUT Parameter 4	SS
(0025,Siemens: Thorax/Multix FD Raw Image Settings,35)	Gamma LUT Name	LO
(0025,Siemens: Thorax/Multix FD Raw Image Settings,36)	Physical Exi	DS
(0025,Siemens: Thorax/Multix FD Raw Image Settings,37)	Clinical Exi	DS
(0029, ISOC 3D NAVIGATIONMATRIX.R. 2.0,00)	NavConfigUID	LO
(0029, ISOC 3D NAVIGATIONMATRIX.R. 2.0,01)	ISOCID	LO
(0029, ISOC 3D NAVIGATIONMATRIX.R. 2.0,02)	ScanID	ST

DICOM Tag	Name	VR
(0029, ISOC 3D NAVIGATIONMATRIX.R. 2.0,03)	CalibrationID	ST
(0029, ISOC 3D NAVIGATIONMATRIX.R. 2.0,04)	Transformation Matrix MA	DS
(0029, ISOC 3D NAVIGATIONMATRIX.R. 2.0,05)	MA Filename	ST
(0029, ISOC 3D NAVIGATIONMATRIX.R. 2.0,06)	No. of projections requested	US
(0029, ISOC 3D NAVIGATIONMATRIX.R. 2.0,07)	No. of Projections done	US
(0029, ISOC 3D NAVIGATIONMATRIX.R. 2.0,08)	SideID	LO
(0029, ISOC 3D NAVIGATIONMATRIX.R. 2.0,09)	NavSenderId	LO
(0029, ISOC 3D NAVIGATIONMATRIX.R. 2.0,10)	NavConfigName	LO

Interpretation of the DICOM Tags from the above table:

(gggg, pp,ee) -> (gggg, ppee)

gggg - odd group number

pp - private creator identification code

ee - private element

9.3 Coded Terminology and Templates

9.3.1 Context Groups

N/A

9.3.2 Template Specifications

The CIARTIC Family will create X-Ray Radiation Dose SRs implementing TID 10001 Projection X-Ray Radiation Dose. For every single irradiation event an entry is made into the SR. Reference Point Definition is "30cm in Front of Image Input" for non isocentric systems and "15cm from Isocenter toward Source" for isocentric systems. The following 3 tables describe main attributes.

Table 93: General X-Ray Dose Data

Concept Name	Comment
Patient Table Relationship	"headfirst", "feetfirst"
Patient Orientation	"recumbent"
Patient orientation Modifier	"supine", "prone", "right lateral decubitus", "left lateral decubitus"

Table 94: Accumulated X-Ray Dose Data

Concept Name	Comment
Dose Area Product Total	The accumulated dose area product (measured with dose chamber) including fluoro and acquisition
Dose (RP) Total	Calculated accumulated dose at the RP applied during fluoro and acquisition
Fluoro Dose Area Product Total	The accumulated dose area product applied during fluoro
Fluoro Dose (RP) Total	Calculated accumulated dose at the RP applied during fluoro
Total Fluoro Time	Total time of fluoro performed in this plane [s].
Acquisition Dose Area Product Total	The accumulated dose area product applied during acquisition
Total Acquisition Time	Total time of acquisition performed in this plane [s].
Distance Source to Reference Point	Distance from the X-Ray Source to the Reference Point
Distance Source to Isocenter	Distance from the X-Ray Source to the Isocenter if C-arm is isocentric.

Table 95: Dose SR Irradiation Event Data

Concept Name	Comment
Irradiation Event Type	Fluoroscopy Stationary Acquisition
Acquisition Protocol	Name of the OGP
Dose Area Product	Dose Area Product applied
Dose (RP)	Calculated dose at the Reference Point
X-Ray Filters	Information about used filter
Fluoro Mode	Pulsed Continuous
Pulse Rate	Used Pulse Rate
Number of Pulses	Number of X-Ray pulses
KVP	Mean value
X-Ray Tube Current	Mean value in mA
Exposure Time	Total time the patient has received X-Ray exposure during the irradiation event.
Pulse Width	Average Pulse Width
Exposure	Exposure in μ As
Target Region	Selected Body Region
Distance Source to Detector	SID in mm
Positioner Primary Angle	Patient-based angle of the primary plane in [deg]. *
Positioner Secondary Angle	Patient-based angle of the secondary plane in [deg]. *
Positioner Primary End Angle	If 3D acquisition was performed: the primary plane end position of the movement in [deg].
Positioner Secondary End Angle	If 3D acquisition was performed: the secondary plane end position of the movement in [deg].
Collimated Field Area	Collimated field area at detector plane in [m2].
Collimated Field Height	Collimated field height at detector plane in [mm].
Collimated Field Width	Collimated field width at detector plane in [mm].
Focal Spot Size	Size of the focal spot in [mm] that was used during the performance of this irradiation event.

* The definition of DICOM "with respect to the patient position" is fulfilled, if the C-arm is moved from the left towards the patient and the detector is positioned above the patient. In case the System has no position sensors the value '0' is set.

9.3.2.1 X-Ray Radiation Dose SR

Table 96: X-Ray Radiation Dose (TID 10001)

NL	Rel with Parent	VT	Concept Name	VM	Presence	Value
		CONTAINER	EV (113701, DCM, "X-Ray Radiation Dose Report")	1	ALWAYS	Root node.
>	HAS CONCEPT MOD	CODE	EV (121058, DCM, "Procedure reported")	1	ALWAYS	DT (113704, DCM, "Projection X-Ray")
>>	HAS CONCEPT MOD	CODE	EV (363703001, SCT, "Has Intent")	1	ALWAYS	EV (R-408C3, SRT, "Diagnostic Intent")

NL	Rel with Parent	VT	Concept Name	VM	Presence	Value
>		INCLUDE	DTID 1002 "Observer Context"	2	ALWAYS	See Table 97
>	HAS OBS CONTEXT	CODE	EV (113705, DCM, "Scope of Accumulation")	1	ALWAYS	EV (113016, DCM, "Performed Procedure Step") or EV (113014, DCM, "Study")
>>	HAS PROPERTIES	UIDREF	EV (121126, DCM, "Performed Procedure Step SOP Instance UID") or EV (110180, DCM, "Study Instance UID")	1	ALWAYS	Study Instance UID or MPPS UID
>	CONTAINS	INCLUDE	DTID 10002 "Accumulated X-Ray Dose"	1	ALWAYS	See Table 98
>	CONTAINS	INCLUDE	DTID 10003 "Irradiation Event X-Ray Data"	1-n	ALWAYS	For each Irradiation Event. See Table 99
>	CONTAINS	TEXT	EV (121106, DCM, "Comment")	1	ALWAYS	Formatted short report.
>	CONTAINS	CODE	EV (113854, DCM, "Source of Dose Information")	1	ALWAYS	EV (15869005, SCT, "Dosimeter")

Table 97: Observer Context (TID 1002)

NL	Rel with Parent	VT	Concept Name	VM	Presence	Value
	HAS OBS CONTEXT	CODE	EV (121005, DCM, "Observer Type")	1	ALWAYS	EV (121006, DCM, "Person")
	HAS OBS CONTEXT	PNAME	EV (121008, DCM, "Person Observer Name")	1	ALWAYS	Value from (0008,1050) or "Not Set". First value is used when two values are available in (0008,1050).
	HAS OBS CONTEXT	CODE	EV (121011, DCM, "Person Observer's Role in this Procedure")	1	ALWAYS	EV (113851, DCM, "Irradiation Administering")
	HAS OBS CONTEXT	CODE	EV (121005, DCM, "Observer Type")	1	ALWAYS	EV (121007, DCM, "Device")
	HAS OBS CONTEXT	UIDREF	EV (121012, DCM, "Device Observer UID")	1	ALWAYS	Root UID including serial number

NL	Rel with Parent	VT	Concept Name	VM	Presence	Value
	HAS OBS CONTEXT	TEXT	EV (121013, DCM, "Device Observer Name")	1	ALWAYS	Value from Station Name
	HAS OBS CONTEXT	TEXT	EV (121014, DCM, "Device Observer Manufacturer")	1	ALWAYS	Value from Manufacturer
	HAS OBS CONTEXT	TEXT	EV (121015, DCM, "Device Observer Model Name")	1	ALWAYS	Value from Manufacturer's Model Name
	HAS OBS CONTEXT	TEXT	EV (121016, DCM, "Device Observer Serial Number")	1	ALWAYS	Value from Device Serial Number

Table 98: Accumulated X-Ray Dose (TID 10002)

NL	Rel with Parent	VT	Concept Name	VM	Presence	Value
		CONTAINER	EV (113702, DCM, "Accumulated X-Ray Dose Data")	1	ALWAYS	
>	HAS CONCEPT MOD	CODE	EV (113764, DCM, "Acquisition Plane")	1	ALWAYS	EV (113622, DCM, "Single Plane")
>	CONTAINS	CONTAINER	EV (122505, DCM, "Calibration")	1	ALWAYS	
>>	HAS CONCEPT MOD	CODE	EV (113794, DCM, "Dose Measurement Device")	1	ALWAYS	EV (A-2C090, SRT, "Dosimeter")
>>	CONTAINS	DATETIME	EV (113723, DCM, "Calibration Date")	1	ALWAYS	Date and time of dosimeter calibration
>>	CONTAINS	NUM	EV (122322, DCM, "Calibration Factor")	1	ALWAYS	1
>>	CONTAINS	NUM	EV (113763, DCM, "Calibration Uncertainty")	1	ALWAYS	Read from local file.
>>	CONTAINS	TEXT	EV (113724, DCM, "Calibration Responsible Party")	1	ALWAYS	Read from local file.
>>	CONTAINS	TEXT	EV (113720, DCM, "Calibration Protocol")	1	ALWAYS	"none"
>	CONTAINS	NUM	EV (113722, DCM, "Dose Area Product Total")	1	ALWAYS	Accumulated dose area product from FLUORO and acquisition.
>	CONTAINS	NUM	EV (113725, DCM, "Dose (RP) Total")	1	ALWAYS	Accumulated entrance dose from FLUORO and acquisition.
>	CONTAINS	NUM	EV (113737, DCM, "Distance Source to Reference Point")	1	ALWAYS	Distance Source to Reference Point

NL	Rel with Parent	VT	Concept Name	VM	Presence	Value
>	CONTAINS	NUM	EV (113731, DCM, "Total Number of Radiographic Frames")	1	ALWAYS	Total Number of Radiographic Frames
>	CONTAINS	NUM	EV (113726, DCM, "Fluoro Dose Area Product Total") ²	1	ANAP	Accumulated dose area product from FLUORO only.
>	CONTAINS	NUM	EV (113728, DCM, "Fluoro Dose (RP) Total") ³	1	ANAP	Accumulated entrance dose from FLUORO only.
>	CONTAINS	NUM	EV (113730, DCM, "Total Fluoro Time") ⁴	1	ANAP	The time the FLUORO switch was pressed.
>	CONTAINS	NUM	EV (113727, DCM, "Acquisition Dose Area Product Total")	1	ALWAYS	Accumulated dose area product from acquisition only.
>	CONTAINS	NUM	EV (113729, DCM, "Acquisition Dose (RP) Total")	1	ALWAYS	Accumulated entrance dose from acquisition only.
>	CONTAINS	NUM	EV (113855, DCM, "Total Acquisition Time")	1	ALWAYS	Total Acquisition Time in Seconds.

Table 99: Irradiation Event X-Ray Data (TID 10003)

NL	Rel with Parent	VT	Concept Name	VM	Presence	Value
		CONTAINER	EV (113706, DCM, "Irradiation Event X-Ray Data")	1	ALWAYS	
>	HAS CONCEPT MOD	CODE	EV (113764, DCM, "Acquisition Plane")	1	ALWAYS	EV (113662, DCM, "Single Plane")
>	CONTAINS	DATETIME	DT (111526, DCM, "DateTime Started")	1	ALWAYS	Date/Time the irradiation event started
>	CONTAINS	CODE	EV (113721, DCM, "Irradiation Event Type")	1	ALWAYS	EV (113611, DCM, "Stationary Acquisition") or EV (44491008, SCT, "Fluoroscopy")
>	CONTAINS	TEXT	EV (125203, DCM, "Acquisition Protocol")	1	ALWAYS	Name of used OGP or FLUORO program
>	CONTAINS	CODE	EV (113745, DCM, "Patient Table Relationship")	1	ALWAYS	For 2D acquisitions: EV (102540008, SCT, "headfirst") For 3D acquisition: EV (102540008, SCT, "headfirst") or EV (102541007, SCT, "feet-first")

² Only present in case of at least one FLUORO event.

³ Only present in case of at least one FLUORO event.

⁴ Only present in case of at least one FLUORO event.

NL	Rel with Parent	VT	Concept Name	VM	Presence	Value
>	CONTAINS	CODE	EV (113743, DCM, "Patient Orientation")	1	ALWAYS	EV (102538003, SCT, "recumbent")
>>	HAS CONCEPT MOD	CODE	EV (113744, DCM, "Patient Orientation Modifier")	1	ALWAYS	For 2D acquisitions: EV (40199007, SCT,"supine") For 3D acquisition: EV (40199007, SCT,"supine"), EV (1240000, SCT,"prone"), EV (102535000, SCT,"right lateral decubitus") or EV (102536004, SCT,"left lateral decubitus")
>	CONTAINS	CODE	EV (113780, DCM,"Reference Point Definition")	1	ALWAYS	EV (113860, DCM, 15cm from Isocenter toward Source)
>	CONTAINS	UIDREF	EV (113769, DCM, "Irradiation Event UID")	1	ALWAYS	Value from Irradiation Event UID (0008,3010)
>	CONTAINS	NUM	EV (122130, DCM, "Dose Area Product")	1	ALWAYS	Dose Area Product for this irradiation event.
>	CONTAINS	NUM	EV (113738, DCM, "Dose (RP)")	1	ALWAYS	Entrance Dose for this irradiation event.
>	CONTAINS	NUM	EV (112011, DCM, "Positioner Primary Angle")	1	ALWAYS	Patient-based angle of the primary plane in [deg]. ⁵
>	CONTAINS	NUM	EV (112012, DCM, "Positioner Secondary Angle")	1	ALWAYS	Patient-based angle of the secondary plane in [deg]. ⁶
>	CONTAINS	CONTAINER	EV (113771, DCM, "X-Ray Filters")	1	ALWAYS	
>>	CONTAINS	CODE	EV (113772, DCM, "X-Ray Filter Type")	1	ALWAYS	EV (111609, DCM, "No Filter") or EV (113650, DCM, "Strip filter")
>>	CONTAINS	CODE	EV (113757, DCM, "X-Ray Filter Material")	1	ANAP	EV (66925006, SCT, "Copper")
>>	CONTAINS	NUM	EV (113758, DCM, "X-Ray Filter Thickness Minimum")	1	ANAP	Thickness of copper filter.
>>	CONTAINS	NUM	EV (113773, DCM, "X-Ray Filter Thickness Maximum")	1	ANAP	Thickness of copper filter.
>	CONTAINS	CODE	EV (113732, DCM, "Fluoro Mode")	1	ALWAYS	EV (113631,DCM,"Pulsed") or EV (113630,DCM,"Continuous")

⁵ The definition of DICOM "with respect to the patient position" is fulfilled, if the C-arm is moved from the left towards the patient and the detector is positioned above the patient. In case the System has no position sensors the value '0' is set.

⁶ The definition of DICOM "with respect to the patient position" is fulfilled, if the C-arm is moved from the left towards the patient and the detector is positioned above the patient. In case the System has no position sensors the value '0' is set.

NL	Rel with Parent	VT	Concept Name	VM	Presence	Value
>	CONTAINS	NUM	EV (113791, DCM, "Pulse Rate") ⁷	1	ANAP	FLUORO frame rate.
>	CONTAINS	NUM	EV (113768, DCM, "Number of Pulses")	1	ALWAYS	Current value
>	CONTAINS	NUM	EV (113742, DCM, "Irradiation Duration")	1	ALWAYS	Current value
>	CONTAINS	NUM	EV (113733, DCM, "KVP")	1	ALWAYS	Current value
>	CONTAINS	NUM	EV (113734, DCM, "X-Ray Tube Current")	1	ALWAYS	Current value
>	CONTAINS	NUM	EV (113824, DCM, "Exposure Time")	1	ALWAYS	Current value
>	CONTAINS	NUM	EV (113793, DCM, "Pulse Width") ⁸	1	ANAP	Current value
>	CONTAINS	NUM	EV (113736, DCM, "Exposure")	1	ALWAYS	Current value
>	CONTAINS	NUM	EV (113742, DCM, "Irradiation Duration")	1	ALWAYS	Current value
>	CONTAINS	NUM	EV (113766, DCM, "Focal Spot Size")	1	ANAP	Current value
>	CONTAINS	NUM	EV (113790, DCM, "Collimated Field Area")	1	ALWAYS	Collimated field area at detector plane in [m2]. All collimator leaves are considered. The collimated field area cannot be calculated from collimated field height and width.
>	CONTAINS	NUM	EV (113788, DCM, "Collimated Field Height")	1	ALWAYS	Collimated field height at detector plane in [mm]. Square or iris collimator are considered to calculate this value.
>	CONTAINS	NUM	EV (113789, DCM, "Collimated Field Width")	1	ALWAYS	Collimated field width at detector plane in [mm]. Square or iris collimator are considered to calculate this value.
>	CONTAINS	NUM	EV (113748, DCM, "Distance Source to Isocenter")	1	ALWAYS	Current value
>	CONTAINS	NUM	EV (113750, DCM, "Distance Source to Detector")	1	ANAP	Current value, only if present
>	CONTAINS	CODE	EV (123014, DCM, "Target Region")	1	ALWAYS	EV (38266002, SCT, "Entire body")
>	CONTAINS	CODE	EV (113876, DCM, "Device Role in Procedure")	1	ALWAYS	EV (113859, DCM, "Irradiating Device")

⁷ Only present in case of pulsed FLUORO.

⁸ Only present in case of pulsed FLUORO.

NL	Rel with Parent	VT	Concept Name	VM	Presence	Value
>>	HAS PROPERTIES	TEXT	EV (113878, DCM, "Device Manufacturer")	1	ALWAYS	SIEMENS
>>	HAS PROPERTIES	TEXT	EV (113879, DCM, "Device Model Name")	1	ALWAYS	Fluorospot Compact S1
>>	HAS PROPERTIES	TEXT	EV (113880, DCM, "Device Serial Number")	1	ALWAYS	Value from Device Serial Number
>	CONTAINS	IMAGE	EV (113795, DCM, "Acquired Image")	1	ANAP	Reference to the image (but only in case an image was created for this event). Not present for FLUOROS.
>	CONTAINS	NUM	EV (113739, DCM, "Positioner Primary End Angle")	1	ALWAYS	Only for 3D acquisitions ⁹
>	CONTAINS	NUM	EV (113740, DCM, "Positioner Secondary End Angle")	1	ALWAYS	Only for 3D acquisitions ¹⁰

9.3.3 Private Code definitions

n.a.

9.4 Grayscale Image Consistency

The high resolution TFT display monitor option of CIARTIC Family comes with a DICOM Grayscale Standard Display Function (GSDF) compliant factory pre-setting. A typical working environment setup is assumed for ambient light.

9.5 Standard Extended / Specialized / Private SOP Classes

The SOP Instances created by CIARTIC Family are standard-extended by adding the following private module attributes.

Table 100: Standard Extended XA

IE	Module	Reference	Usage	Note
Image	Post Processing	9.5.1 Post Processing Module	U	additional private Information about post processing
	Acquisition Data	9.5.2 Acquisition Data Module	U	additional private Information about image acquisition
	Lab Settings	9.5.3 Lab Settings Module	U	additional private Information about lab settings
	VDM Data	9.5.4 VDM Data Module	U	additional private Information about VDM settings
	Navigation Data	9.5.6 Navigation Data Module	U	additional private Information about navigation settings

⁹ The definition of DICOM "with respect to the patient position" is fulfilled if the C-arm is moved from the left towards the patient and the detector is positioned above the patient. In case the System has no position sensors the value '0' is set.

¹⁰ The definition of DICOM "with respect to the patient position" is fulfilled if the C-arm is moved from the left towards the patient and the detector is positioned above the patient. In case the System has no position sensors the value '0' is set.

	Raw Image	9.5.5 Raw Image Module	U	additional private Information about raw image settings
--	-----------	------------------------	---	---------------------------------------------------------

U = User Option

9.5.1 Post Processing Module

Following shadow owner code is used: "Siemens: Thorax/Multix FD Post Processing"

9.5.2 Acquisition Data Module

Following shadow owner code is used: "SIEMENS_FLCOMPACT_VA01A_PROC".

9.5.3 Lab Settings Module

Following shadow owner code is used: "Siemens: Thorax/Multix FD Lab Settings".

9.5.4 VDM Data Module

Following shadow owner code is used: "VDM_VA30".

9.5.5 Raw Image Module

Following shadow owner code is used: "Siemens: Thorax/Multix FD Raw Image Settings".

9.5.6 Navigation Data Module

Following shadow owner code is used: "ISOC 3D NAVIGATIONMATRIX.R. 2.0".

9.6 Private Transfer Syntaxes

No private Transfer Syntaxes are defined for or requested by CIARTIC Family DICOM application.

Annex A: Index of Tables

Table 1: Network Services.....	2
Table 2: Media Services	3
Table 3: Implementation Identifying Information	3
Table 4: Presentation Context Table "Verification"	18
Table 5: Presentation Context Table "Verification"	19
Table 6: Proposed Presentation Contexts for Storage.....	21
Table 7: Status Codes "Save to local disk"	22
Table 8: Storage C-STORE-RSP Status	23
Table 9: Proposed Presentation Contexts for Storage Commitment	25
Table 10: Proposed Presentation Contexts for Query.....	27
Table 11: DICOM Command Response Status Handling Behavior	28
Table 12: Attributes supported for Study/Series Query – SCU	28
Table 13: Proposed Presentation Contexts for Retrieve and Activity "Send Move Request"	30
Table 14: DICOM Command Response Status Handling Behavior	30
Table 15: Proposed Presentation Contexts for Worklist	32
Table 16: Broad Query search keys.....	32
Table 17: Modality Worklist C-Find Return keys	33
Table 18: DICOM Command Response Status Handling Behavior	36
Table 19: Patient based "narrow query" Search Keys	37
Table 20: Acceptable Presentation Contexts Activity "Create MPPS"	39
Table 21: MPPS N-CREATE-RSP Status Handling Behavior	39
Table 22: Attributes supported in MPPS N-CREATE-RQ	39
Table 23: MPPS N-SET-RSP Status Handling Behavior	43
Table 24: Presentation Contexts for the Activity "Print Film"	47
Table 25: Attributes for the N-CREATE-RQ of the Basic Film Session	47
Table 26: Requested SOP Instance UID on the Basic Film Session	48
Table 27: N-CREATE-RSP Status Handling Behavior for the Basic Film Session	48
Table 28: Attributes for the N-CREATE-RQ of the Basic Film Box	48
Table 29: Requested SOP Instance UID on the Basic Film Box.....	49
Table 30: N-ACTION-RSP Status Handling Behavior for Basic Film Box.....	49
Table 31: Attributes for N-SET-RQ of Basic Grayscale Image Box	51
Table 32: N-SET-RSP Status Handling Behavior for the Basic Grayscale Image Box SOP Class	51
Table 33: Attributes for N-CREATE-RQ of Presentation LUT SOP Class	51
Table 34: Requested SOP Instance UID on the LUT.....	52
Table 35: N-CREATE-RSP Status Handling Behavior for the Presentation LUT SOP Class	52
Table 36: Used Printer N-EVENT Report attributes	52
Table 37: Mandatory Printer N-GET-RSP, N-EVENT-REPORT-RQ attributes	53
Table 38: AE Titles	53
Table 39 - Remote AE Configuration Items.....	54
Table 40: Parameter List	56
Table 41: Media - Application Profiles and Real World Activities.....	58
Table 42: STD-GEN-xxx profile supported SOP Classes	58
Table 43: STD-GEN-xxx profile supported SOP Classes	59
Table 44: Application Level Confidentiality Profile attributes (standard tags)	61
Table 45: IOD of Created XA SOP Instances – Acquired and Derived Images.....	64
Table 46: IOD of Enhanced CT Volume	66
Table 47: IOD of CT Volume	67
Table 48: IOD of Multiframe True Color Secondary Capture Image	68
Table 49: IOD of Created Secondary Capture SOP Instances	69
Table 50: IOD of Created X-Ray Radiation Dose SR SOP Instances	70
Table 51: Patient Module.....	72
Table 52: General Study Module.....	72
Table 53: Patient Study Module	73
Table 54: General Series and Enhanced Series Module	74
Table 55: General Equipment Module.....	76
Table 56: General Image Module	77
Table 57: Image Pixel Module	78
Table 58: SOP Common Module.....	78
Table 59: Multi-frame Module.....	79

Table 60: Frame of Reference Module.....	79
Table 61: VOI LUT Module.....	80
Table 62: Overlay Plane Module.....	80
Table 63: Contrast/Bolus Module.....	81
Table 64: Cine Module.....	81
Table 65: Frame Pointers Module.....	81
Table 66: Mask Module.....	81
Table 67: X-Ray Image Module.....	82
Table 68: X-Ray Filtration Module.....	82
Table 69: X-Ray Acquisition Module.....	82
Table 70: X-Ray Collimator Module.....	83
Table 71: XA Positioner Module.....	84
Table 72: DX Detector Module.....	84
Table 73: Modality LUT Module.....	85
Table 74: Multi-Frame Functional Groups Module.....	86
Table 75: Multi-Frame Dimension Module.....	88
Table 76: Enhanced CT Image Module.....	89
Table 77: Acquisition Context Module.....	89
Table 78: Multi-frame Overlay Module.....	90
Table 79: Image Plane Module.....	90
Table 80: CT Image Module.....	90
Table 81: SC Equipment Module.....	91
Table 82: SR Document Series Module.....	91
Table 83: SR Document General Module.....	91
Table 84: SR Document Content Module.....	92
Table 85: Private Data Element Dictionary - SIEMENS_FLCOMPACT_VA01A_PROC.....	92
Table 86: Private Data Element Dictionary – Siemens: Thorax/Multix FD Lab Settings.....	95
Table 87: Private Data Element Dictionary – Siemens: Thorax/Multix FD Post Processing.....	95
Table 88: Private Data Element Dictionary - VDM_VA30.....	96
Table 89: Private Data Element Dictionary – Siemens: Thorax/Multix FD Raw Image Settings.....	96
Table 90: Private Data Element Dictionary - ISOC 3D NAVIGATIONMATRIX.R. 2.0.....	97
Table 91: Image Type Extensions.....	99
Table 92: Private Data Element Dictionary.....	100
Table 93: General X-Ray Dose Data.....	105
Table 94: Accumulated X-Ray Dose Data.....	105
Table 95: Dose SR Irradiation Event Data.....	106
Table 96: X-Ray Radiation Dose (TID 10001).....	106
Table 97: Observer Context (TID 1002).....	107
Table 98: Accumulated X-Ray Dose (TID 10002).....	108
Table 99: Irradiation Event X-Ray Data (TID 10003).....	109
Table 100: Standard Extended XA.....	112

Annex B: Table of Figures

Figure 1: CIARTIC Family DICOM Data Flow diagram 12
Figure 2: Sequence Diagram - System Configuration Workflow 14
Figure 3: Sequence Diagram - Acquisition workflow 15
Figure 4: Printing 16
Figure 5: Media Interchange Application Data Flow Diagram 57
Figure 6: X-Ray Radiation Dose SR IOD Template Structure 70

On account of certain regional limitations of sales rights and service availability, we cannot guarantee that all products included in this brochure are available through the Siemens Healthineers sales organization worldwide. Availability and packaging may vary by country and are subject to change without prior notice.

Some / All of the features and products described herein may not be available in the United States or other countries.

The information in this document contains general technical descriptions of specifications and options as well as standard and optional features that do not always have to be present in individual cases.

Siemens Healthineers reserves the right to modify the design, packaging, specifications and options described herein without prior notice. Please contact your local Siemens Healthineers sales representative for the most current information.

In the interest of complying with legal requirements concerning the environmental compatibility of our products (protection of natural resources and waste conservation), we recycle certain components. Using the same extensive quality assurance measures as for factory-new components, we guarantee the quality of these recycled components.

Siemens Healthineers Headquarters

Siemens Healthineers AG
Siemensstr. 3
91301 Forchheim, Germany
Phone: +49 9191 18-0
siemens-healthineers.com

Manufacturer

Siemens Healthcare GmbH
Henkestr. 127
91052 Erlangen
Germany

Published by Siemens Healthineers AG - A91AT-40040-55T2-7600 - Printed in Germany - © Siemens Healthineers AG, 2024