

DICOM Conformance Statement

Biograph Vision VG85A

Product Name

Biograph Vision

The DICOM Conformance Statement is also valid for regional product variants and configurations.

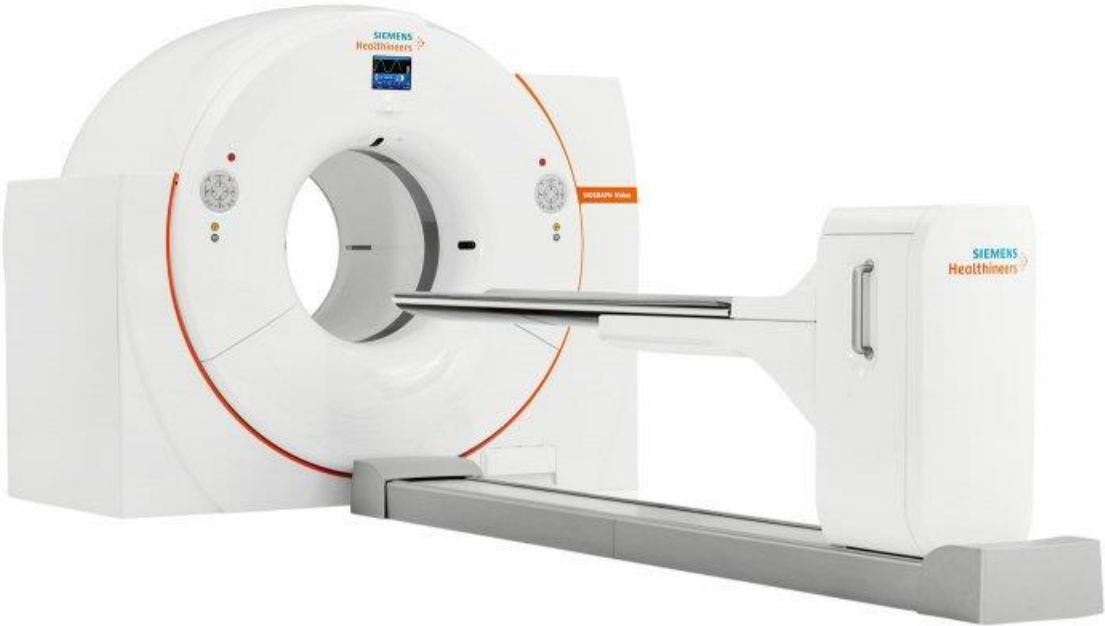

1 Conformance Statement Overview

The Biograph Vision conforms to the DICOM Standard and supports the network services as described in [Table 1: Network Services](#) and the media services as described in [Table 2: Media Services](#)

Table 1: Network Services

SOP Classes	SOP Class UID	User of Service (SCU)		Provider of Service (SCP)	
Transfer					
SOP Classes	SOP Class UID	User of Service (SCU)		Provider of Service (SCP)	
		Create	Send	Store	Display
Transfer (Image SOP Class)					
Computed Radiography Image Storage	1.2.840.10008.5.1.4.1.1.1	No	Yes	Yes	Yes
Digital X-Ray Image Storage - For Presentation	1.2.840.10008.5.1.4.1.1.1.1	No	Yes	Yes	Yes
Digital X-Ray Image Storage – For Processing	1.2.840.10008.5.1.4.1.1.1.1.1	No	Yes	Yes	Yes
Digital Mammography X-Ray Image Storage – For Presentation	1.2.840.10008.5.1.4.1.1.1.2	No	Yes	Yes	Yes
Digital Mammography X-Ray Image Storage – For Processing	1.2.840.10008.5.1.4.1.1.1.2.1	No	Yes	Yes	Yes
Digital Intra-Oral X-Ray Image - For Presentation	1.2.840.10008.5.1.4.1.1.1.3	No	Yes	Yes	Yes
Digital Intra-Oral X-Ray Image - For Processing	1.2.840.10008.5.1.4.1.1.1.3.1	No	Yes	Yes	Yes
CT Image Storage	1.2.840.10008.5.1.4.1.1.2	Yes	Yes	Yes	Yes
Enhanced CT Image Storage ¹	1.2.840.10008.5.1.4.1.1.2.1	No	Yes	Yes	Yes
Ultrasound Multi-frame Image Storage (retired)	1.2.840.10008.5.1.4.1.1.3	No	No	Yes	Yes
Ultrasound Multi-frame Image Storage	1.2.840.10008.5.1.4.1.1.3.1	No	Yes	Yes	Yes
MR Image Storage	1.2.840.10008.5.1.4.1.1.4	No	Yes	Yes	Yes
Enhanced MR Image Storage ²	1.2.840.10008.5.1.4.1.1.4.1	No	Yes	Yes	Yes
Enhanced MR Color Image Storage	1.2.840.10008.5.1.4.1.1.4.3	No	Yes	Yes	Yes

¹ Transfer is only possible when the receiving node is configured with “Supports Enhanced Data”

² Transfer is only possible when the receiving node is configured with “Supports Enhanced Data”

SOP Classes	SOP Class UID	User of Service (SCU)		Provider of Service (SCP)	
Ultrasound Image Storage (retired)	1.2.840.10008.5.1.4.1.1.6	No	No	Yes	Yes
Ultrasound Image Storage	1.2.840.10008.5.1.4.1.1.6.1	No	Yes	Yes	Yes
Secondary Capture Image Storage	1.2.840.10008.5.1.4.1.1.7	Yes	Yes	Yes	Yes
Multi-frame Single Bit Secondary Capture Image Storage	1.2.840.10008.5.1.4.1.1.7.1	No	Yes	Yes	Yes
Multi-frame Grayscale Byte Secondary Capture Image Storage	1.2.840.10008.5.1.4.1.1.7.2	No	Yes	Yes	Yes
Multi-frame Grayscale Word Secondary Capture Image Storage	1.2.840.10008.5.1.4.1.1.7.3	No	Yes	Yes	Yes
Multi-frame True Color Secondary Capture Image Storage	1.2.840.10008.5.1.4.1.1.7.4	No	Yes	Yes	Yes
X-Ray Angiographic Image Storage	1.2.840.10008.5.1.4.1.1.12.1	No	Yes	Yes	Yes
X-Ray Radiofluoroscopic Image Storage	1.2.840.10008.5.1.4.1.1.12.2	No	Yes	Yes	Yes
X-Ray 3D Angiographic Image Storage ³	1.2.840.10008.5.1.4.1.1.13.1.1	No	Yes	Yes	Yes
Breast Tomosynthesis Image Storage ⁴	1.2.840.10008.5.1.4.1.1.13.1.3	No	Yes	Yes	Yes
Nuclear Medicine Image Storage	1.2.840.10008.5.1.4.1.1.20	No	Yes	Yes	Yes
Segmentation Storage	1.2.840.10008.5.1.4.1.1.66.4	No	Yes	Yes	Yes
Positron Emission Tomography Image Storage	1.2.840.10008.5.1.4.1.1.128	Yes	Yes	Yes	Yes
RT Image Storage	1.2.840.10008.5.1.4.1.1.481.1	No	Yes	Yes	No
RT Dose Storage	1.2.840.10008.5.1.4.1.1.481.2	No	Yes	Yes	Yes
Transfer (Non-Image SOP Class)					
MR Spectroscopy Storage	1.2.840.10008.5.1.4.1.1.4.2	No	Yes	Yes	Yes
12-lead ECG Waveform Storage	1.2.840.10008.5.1.4.1.1.9.1.1	No	Yes	Yes	No
General ECG Waveform Storage	1.2.840.10008.5.1.4.1.1.9.1.2	No	Yes	Yes	No
Ambulatory ECG Waveform Storage	1.2.840.10008.5.1.4.1.1.9.1.3	No	Yes	Yes	No

³ Transfer is only possible when the receiving node is configured with "Supports Enhanced Data"

⁴ Transfer is only possible when the receiving node is configured with "Supports Enhanced Data"

SOP Classes	SOP Class UID	User of Service (SCU)		Provider of Service (SCP)	
		No	Yes	Yes	No
Hemodynamic Waveform Storage	1.2.840.10008.5.1.4.1.1.9.2.1	No	Yes	Yes	No
Cardiac Electrophysiology Waveform Storage	1.2.840.10008.5.1.4.1.1.9.3.1	No	Yes	Yes	No
Basic Voice Audio Waveform Storage	1.2.840.10008.5.1.4.1.1.9.4.1	No	Yes	Yes	No
Grayscale Softcopy Presentation State Storage	1.2.840.10008.5.1.4.1.1.11.1	No	Yes	Yes	Yes
Raw Data Storage	1.2.840.10008.5.1.4.1.1.66	No	Yes	Yes	No
Spatial Registration Storage	1.2.840.10008.5.1.4.1.1.66.1	No	Yes	Yes	Yes
Spatial Fiducials Storage	1.2.840.10008.5.1.4.1.1.66.2	No	Yes	Yes	Yes
Surface Segmentation Storage	1.2.840.10008.5.1.4.1.1.66.5	No	Yes	Yes	Yes
Basic Text SR Storage	1.2.840.10008.5.1.4.1.1.88.11	No	Yes	Yes	Yes
Enhanced SR Storage	1.2.840.10008.5.1.4.1.1.88.22	No	Yes	Yes	Yes
Comprehensive SR Storage	1.2.840.10008.5.1.4.1.1.88.33	Yes	Yes	Yes	Yes
Procedure Log Storage	1.2.840.10008.5.1.4.1.1.88.40	No	Yes	Yes	Yes
Mammography CAD SR Storage	1.2.840.10008.5.1.4.1.1.88.50	No	Yes	Yes	Yes
Key Object Selection Document Storage	1.2.840.10008.5.1.4.1.1.88.59	No	Yes	Yes	Yes
Chest CAD SR Storage	1.2.840.10008.5.1.4.1.1.88.65	No	Yes	Yes	Yes
X-Ray Radiation Dose SR Storage	1.2.840.10008.5.1.4.1.1.88.67	Yes	Yes	Yes	Yes
Radiopharmaceutical Radiation Dose SR Storage	1.2.840.10008.5.1.4.1.1.88.68	Yes	Yes	Yes	Yes
Encapsulated PDF Storage	1.2.840.10008.5.1.4.1.1.104.1	Yes	Yes	Yes	Yes
RT Structure Set Storage	1.2.840.10008.5.1.4.1.1.481.3	No	Yes	Yes	No
RT Beams Treatment Record Storage	1.2.840.10008.5.1.4.1.1.481.4	No	Yes	Yes	No
RT Plan Storage	1.2.840.10008.5.1.4.1.1.481.5	No	Yes	Yes	No
RT Brachy Treatment Record Storage	1.2.840.10008.5.1.4.1.1.481.6	No	Yes	Yes	No
RT Treatment Summary Record Storage	1.2.840.10008.5.1.4.1.1.481.7	No	Yes	Yes	No
RT Ion Plan Storage	1.2.840.10008.5.1.4.1.1.481.8	No	Yes	Yes	Yes
RT Ion Beams Treatment Record Storage	1.2.840.10008.5.1.4.1.1.481.9	No	Yes	Yes	Yes

SOP Classes	SOP Class UID	User of Service (SCU)		Provider of Service (SCP)	
Transfer (Private SOP Class)					
CSA Non-Image Storage	1.3.12.2.1107.5.9.1	Yes	Yes	Yes	No
Query/Retrieve					
Patient Root Q/R Information Model - FIND	1.2.840.10008.5.1.4.1.2.1.1	Yes		Yes	
Patient Root Q/R - Information Model - MOVE	1.2.840.10008.5.1.4.1.2.1.2	Yes		Yes	
Patient Root Q/R - Information Model - GET	1.2.840.10008.5.1.4.1.2.1.3	Yes ⁵		Yes	
Study Root Q/R - Information Model - FIND	1.2.840.10008.5.1.4.1.2.2.1	Yes		Yes	
Study Root Q/R - Information Model - MOVE	1.2.840.10008.5.1.4.1.2.2.2	Yes		Yes	
Study Root Q/R - Information Model - GET	1.2.840.10008.5.1.4.1.2.2.3	Yes ⁶		Yes	
Patient/Study Only Q/R - Information Model FIND	1.2.840.10008.5.1.4.1.2.3.1	Yes		Yes	
Patient/Study Only Q/R - Information Model MOVE	1.2.840.10008.5.1.4.1.2.3.2	Yes		Yes	
Patient/Study Only Q/R - Information Model GET	1.2.840.10008.5.1.4.1.2.3.3	Yes ⁷		Yes	
Workflow Management					
Modality Worklist Information Model – FIND	1.2.840.10008.5.1.4.31	Yes		No	
Modality Performed Procedure Step	1.2.840.10008.3.1.2.3.3	Yes		No	
Storage Commitment Push Model	1.2.840.10008.1.20.1	Yes		No	
Print Management					
Basic Grayscale Print Management Meta SOP Class	1.2.840.10008.5.1.1.9	Yes		No	
Basic Color Print Management Meta SOP Class	1.2.840.10008.5.1.1.18	Yes		No	
Basic Film Session SOP Class	1.2.840.10008.5.1.1.1	Yes		No	
Basic Film Box SOP Class	1.2.840.10008.5.1.1.2	Yes		No	

⁵ The DICOM C GET Service is supported in addition by syngo Study Transfer application

⁶ The DICOM C GET Service is supported in addition by syngo Study Transfer application

⁷ The DICOM C GET Service is supported in addition by syngo Study Transfer application

SOP Classes	SOP Class UID	User of Service (SCU)	Provider of Service (SCP)
Basic Grayscale Image Box SOP Class	1.2.840.10008.5.1.1.4	Yes	No
Basic Color Image Box SOP Class	1.2.840.10008.5.1.1.4.1	Yes	No
Printer SOP Class	1.2.840.10008.5.1.1.16	Yes	No
Print Job SOP Class	1.2.840.10008.5.1.1.14	Yes	No
Presentation LUT SOP Class	1.2.840.10008.5.1.1.23	Yes	No

Table 2: Media Services

Media Storage Application Profile	Write Files (FSC or FSU)	Read Files (FSR)
Compact Disk - Recordable		
<i>syngo</i> System on CD-R (PRI-SYNGO-CD)	Yes	Yes
Augmented General Purpose CD-R Interchange (AUG-GEN-CD)	Yes ⁸	Yes
General Purpose CD-R Interchange (STD-GEN-CD)	No	Yes
DVD		
<i>syngo</i> System on DVD-R (PRI-SYNGO-DVD)	Yes	Yes
Augmented General Purpose DVD Interchange with JPEG (AUG-GEN-DVD-JPEG)	Yes	Yes
General Purpose DVD Interchange with JPEG (STD-GEN-DVD-JPEG)	No	Yes
General Purpose DVD Interchange with JPEG 2000 (STD-GEN-DVD-J2K)	No	Yes
USB⁹ and Flash Memory		
<i>syngo</i> System on USB (PRI-SYNGO-USB)	Yes	Yes
Augmented General Purpose USB Media Interchange with JPEG (AUG-GEN-USB-JPEG)	Yes	Yes
General Purpose USB Media Interchange with JPEG (STD-GEN-USB-JPEG)	No	Yes
General Purpose USB Media Interchange with JPEG-2000 (STD-GEN-USB-J2K)	No	Yes

⁸ with uncompressed setting⁹ Browser support for the USB needs to be configured in the Biograph Vision local service page else USB will act as offline device.

Table 3: Implementation Identifying Information

Name	Value
Application Context Name	1.2.840.100008.3.1.1.1
Implementation Class UID	1.3.12.2.1107.5.1.4 (for CT, PET) 1.3.12.2.1107.5.99.3.20080101 (for Secondary Capture, PDF, Segmentation)
Implementation Version Name	SIEMENS_S7VB30A

2 Table of Contents

1	CONFORMANCE STATEMENT OVERVIEW	2
2	TABLE OF CONTENTS	8
3	INTRODUCTION	11
3.1	Revision History	11
3.2	Audience	11
3.3	Remarks	11
3.4	Terms and Definitions	11
3.5	Basics of DICOM Communication	13
3.6	Abbreviations	14
3.7	References	15
4	NETWORKING	16
4.1	Implementation Model	16
4.1.1	Application Data Flow	16
4.1.2	Functional Definition of AEs	18
4.1.3	Sequencing of Real World Activities	20
4.2	AE Specifications	26
4.2.1	Storage AE Specification	26
4.2.2	Print AE Specification	54
4.2.3	Workflow AE Specification	65
4.3	Network Interfaces	86
4.3.1	Physical Network Interface	86
4.3.2	Additional Protocols	86
4.3.3	IPv4 and IPv6 Support	86
4.4	Configuration	86
4.4.1	AE Title / Presentation Address Mapping	86
4.4.2	Parameters	88
5	MEDIA INTERCHANGE	90
5.1	Implementation Model	90

5.1.1	Application Data Flow Diagram	90
5.1.2	Functional Definitions of AEs	91
5.1.3	Sequencing of Real World Activities	91
5.1.4	File Meta Information for Implementation Class and Version	91
5.2	AE Specifications	91
5.2.1	DICOM Archive – Specification	91
5.3	Augmented and Private Application Profiles	94
5.3.1	Augmented Application Profiles	94
5.3.2	Private Application Profiles	96
5.4	Media Configuration	111
5.4.1	Auto-Labeling	111
5.4.2	Compression	111
5.4.3	Private SOP Class export	111
5.4.4	Browser support for USB device	112
6	TRANSFORMATION OF DICOM TO CDA	113
7	SUPPORT OF CHARACTER SETS	114
8	SECURITY	118
8.1	Security Profiles	118
8.2	Association Level Security	120
8.3	Application-Level Security	121
8.4	Media storage attribute confidentiality	121
8.4.1	De-identification	121
9	ANNEXES	124
9.1	IOD Contents	124
9.1.1	Created SOP Instance(s)	124
9.1.2	Usage of Attributes From Received IODs	190
9.1.3	Attribute Mapping	190
9.1.4	Coerced/Modified Fields	190
9.2	Data Dictionary of Private Attributes	190
9.2.1	Private Elements for all Storage SOP Classes	190
9.2.2	Private Elements for CT Image Storage SOP Class	192
9.3	Coded Terminology and Templates	194
9.3.1	Context Groups	194
9.3.2	Template Specifications	201

9.3.3	Private Code Definitions	208
9.4	Grayscale Image Consistency	209
9.5	Standard Extended / Specialized / Private SOP Classes	209
9.5.1	Standard Extensions	209
9.5.2	Specializations	225
9.5.3	Private SOP Classes	225
9.6	Private Transfer Syntaxes	227
9.7	DICOM Print SCU - detailed status displays	227

3 Introduction

This document is applicable to Siemens Healthineers Biograph Vision products using software Biograph Vision on Somaris/7, which is running under Windows 10.

3.1 Revision History

Version	Date	Product Version	Change
1	2024-06-11	VG85A	Modified structure to be in alignment with PS3.2
2	2026-03-03	VG85A Version 02	Revised the document to incorporate review feedback, including corrections to documentation inaccuracies, indentation issues, and streamlining all deviated tables and content to ensure alignment with DICOM standards

3.2 Audience

This document is intended for hospital staff, health system integrators, software designers or implementers. It is assumed that the reader has a working understanding of DICOM.

3.3 Remarks

The scope of this DICOM Conformance Statement is to facilitate integration between Biograph Vision and other DICOM products. The Conformance Statement should be read and understood in conjunction with the DICOM Standard [1]. DICOM by itself does not guarantee interoperability.

The Conformance Statement does, however, facilitate a first-level comparison for interoperability between different applications supporting compatible DICOM functionality.

This Conformance Statement is not supposed to replace validation with other DICOM equipment to ensure proper exchange of intended information. In fact, the user should be aware of the following important issues:

- The comparison of conformance statements is the first step towards assessing interconnectivity and interoperability between Biograph Vision products and other DICOM conformant equipment.
- Test procedures should be defined and executed to validate the required level of interoperability with specific compatible DICOM equipment, as established by the healthcare facility.

Siemens Healthineers reserves the right to modify the design and specifications contained herein without prior notice. Please contact your local Siemens Healthineers representative for the most recent product information.

3.4 Terms and Definitions

The following table gives an overview of frequently used terms in this document.

Table 4: Terms and Definitions

Term	Definition
Abstract Syntax	The information agreed to be exchanged between applications, generally equivalent to a Service/Object Pair (SOP) Class. Examples: Verification SOP Class, Modality Worklist Information Model Find SOP Class, Computed Radiography Image Storage SOP Class.
Application Entity (AE)	A representation of the external behaviour of an application process in terms of DICOM Network Services, Web Services and/or media exchange capabilities implemented in one or more roles. A single device may have multiple Application Entities.

Application Entity Title (AET)	The externally known name of an Application Entity, used to identify a DICOM application to other DICOM applications on the network.
Application Context	The specification of the type of communication used between Application Entities. Example: DICOM network protocol.
Association	A network communication channel set up between Application Entities.
Attribute	A unit of information in an Information Object Definition; a Data Element identified by a tag. The information may be a complex data structure (Sequence), itself composed of lower-level data elements. Examples: Patient ID (0010,0020), Accession Number (0008,0050), Photometric Interpretation (0028,0004), Procedure Code Sequence (0008,1032).
Data Element	A unit of information as defined by a single entry in the data dictionary. An encoded Information Object Definition (IOD) Attribute that is composed of, at a minimum, three fields: a Data Element Tag, a Value Length, and a Value Field. For some specific Transfer Syntaxes, a Data Element also contains a VR Field where the Value Representation of that Data Element is specified explicitly
Information Object Definition (IOD)	The specified set of Attributes that comprise a type of data object; does not represent a specific instance of the data object, but rather a class of similar data objects that have the same properties. Examples: MR Image IOD, CT Image IOD, Print Job IOD. The Attributes within an IOD may be specified as Mandatory (Type 1), Required but possibly unknown (Type 2), or Optional (Type 3), and there may be conditions associated with the use of an Attribute (Types 1C and 2C).
Media Application Profile	The specification of DICOM information objects and encoding exchanged on removable media (e.g., CDs).
Module	A set of Attributes within an Information Object Definition that are logically related to each other. Example: Patient Module includes Patient's Name, Patient ID, Patient' Birth Date, and Patient's Sex.
Negotiation	First phase of Association establishment that allows Application Entities to agree on the types of data to be exchanged and how that data will be encoded.
Origin Server	Refers to the program that can originate authoritative responses to HTTP requests for a given Target Resource. The term "server" refers to any implementation that receives a web service request message from a user agent.
PHASED	Divides the beat evenly into gates.
Presentation Context	The set of DICOM Network Services used over an Association, as negotiated between Application Entities; includes Abstract Syntaxes and Transfer Syntaxes.
Private SOP Class	A SOP Class that is not defined in the DICOM Standard but is published in an implementation's Conformance Statement.
Protocol Data Unit (PDU)	A packet (piece) of a DICOM message sent across the network. Devices must specify the maximum size packet they can receive for DICOM messages.
Security Profile	A set of mechanisms, such as encryption, user authentication, or digital signatures, used by an Application Entity to ensure confidentiality, integrity, and/or availability of exchanged DICOM data.
Service Class Provider (SCP)	Role of an Application Entity that provides a DICOM network service; typically, a server that performs operations requested by another Application Entity (Service Class User). Examples: Picture Archiving and Communication System (image storage SCP, and image query/retrieve SCP), Radiology Information System (modality worklist SCP).
Service Class User (SCU)	Role of an Application Entity that uses a DICOM Network Service; typically, a client. Examples: imaging modality (image storage SCU, and modality worklist SCU), imaging workstation (image query/retrieve SCU).
Service/Object Pair Class (SOP Class)	The specification of the network or media transfer (service) of a particular type of data (object) ; the fundamental unit of a DICOM interoperability specification. Examples: Ultrasound Image Storage Service, Basic Grayscale Print Management.

Service/Object Pair Instance (SOP Instance)	An information object; a specific occurrence of information exchanged in a SOP Class. E.g., a specific X-ray image.
Specialized SOP Class	A SOP Class that is derived from the Standard that is specialized by additional type 1, 1C, 2, 2C, or 3 Attributes, by enumeration of specific permitted Values for Attributes, or by enumeration of specific permitted Templates. The additional Attributes may either be drawn from the Data Dictionary in PS3.6 or may be Private Attributes.
Standard SOP Class	A SOP Class defined in the Standard, and that is implemented and used without any modifications.
Standard Extended SOP Class	A SOP Class that is defined in the standard, and that is extended by additional type 3 Attributes. The additional Attributes may either be drawn from the DICOM Data Dictionary in PS3.6 or may be Private Attributes.
Tag	A 32-bit identifier for a Data Element, represented as a pair of four-digit hexadecimal numbers, the "group" and the "element". If the "group" number is odd, the tag is for a private (manufacturer-specific) data element. Examples: (0010,0020) [Patient ID], (07FE,0010) [Pixel Data], (0019,0210) [private data element].
Transfer Syntax	The encoding used for exchange of DICOM information objects and messages. Examples: JPEG compressed (images), Little Endian Explicit Value Representation.
TLS-Secured Port	TCP port on which an implementation accepts TLS connections to exchange DICOM information.
Unique Identifier (UID)	A globally unique "dotted decimal" string that identifies a specific object or a class of objects; an ISO-8824 Object Identifier. Examples: Study Instance UID, SOP Class UID, SOP Instance UID.
User Agent	A client in a network protocol used in communications within a client-server distributed computing system. In particular, the Hypertext Transfer Protocol (HTTP) identifies the client software originating the request, using a user-agent header, even when the client is not operated by a user.
Value Representation (VR)	The format type of an individual DICOM data element, such as text, an integer, a person's name, or a code. DICOM information objects can be transmitted with either explicit identification of the type of each data element (Explicit VR), or without explicit identification (Implicit VR) ; with Implicit VR, the receiving application must use a DICOM data dictionary to look up the format of each data element.

3.5 Basics of DICOM Communication

This section describes terminology used in this Conformance Statement for the non-specialist. The key terms used in the Conformance Statement are highlighted in *italics* below. This section is not a substitute for training about DICOM, and it makes many simplifications about the meanings of DICOM terms.

Two *Application Entities* (devices) that want to communicate with each other over a network using DICOM protocol must first agree on several things during an initial network "handshake". One of the two devices must initiate an Association (a connection to the other device), and ask if specific services, information, and encoding can be supported by the other device (*Negotiation*).

DICOM specifies a number of network services and types of information objects, each of which is called an *Abstract Syntax* for the Negotiation. DICOM also specifies a variety of methods for encoding data, denoted *Transfer Syntaxes*. The Negotiation allows the initiating Application Entity to propose combinations of Abstract Syntax and Transfer Syntax to be used on the Association; these combinations are called *Presentation Contexts*. The receiving Application Entity accepts the Presentation Contexts it supports.

For each Presentation Context, the Association Negotiation also allows the devices to agree on *Roles* - which one is the *Service Class User* (SCU - client) and which is the *Service Class Provider* (SCP - server). Normally the device initiating the connection is the SCU, i.e., the client system calls the server, but not always.

The Association Negotiation finally enables exchange of maximum network packet (*PDU*) size, security information, and network service options (called *Extended Negotiation* information).

The Application Entities, having negotiated the Association parameters, may now commence exchanging data. Common data exchanges include queries for worklists and lists of stored images, transfer of image objects and analyses (structured reports), and sending images to film printers. Each exchangeable unit of data is formatted by the sender in accordance with the appropriate *Information Object Definition* and sent using the negotiated Transfer Syntax. There is a Default Transfer Syntax that all systems must accept, but it may not be the most efficient for some use cases. Each transfer is explicitly acknowledged by the receiver with a *Response Status* indicating success, failure, or that query or retrieve operations are still in process.

Two Application Entities may also communicate with each other by exchanging media (such as a CD-R). Since there is no Association Negotiation possible, they both use a *Media Application Profile* that specifies "pre-negotiated" exchange media format, Abstract Syntax, and Transfer Syntax.

3.6 Abbreviations

Abbreviations that are used in this DICOM Conformance Statement are listed here.

Table 5: Abbreviations

Abbreviation	Description
AE	Application Entity
AET	Application Entity Title
ANAP	Attribute not always present
ASCII	American Standard Code for Information Interchange
CDA	Clinical Document Architecture
CD-R	Compact Disk Recordable
CSA	Common Software Architecture
DCID	Defined Context Group Identifier
DCS	DICOM Conformance Statement
DICOM	Digital Imaging and Communications in Medicine
DT	Defined Term
DTID	Defined Template Identifier
EV	Enumerated Value
FSC	File Set Creator
FSR	File Set Reader
FSU	File Set Updater
GSDf	Grayscale Standard Display Function
GSPS	Grayscale Softcopy Presentation State
HIS	Hospital Information System
IHE	Integrating the Healthcare Enterprise
IOD	DICOM Information Object Definition
ISO	International Standard Organization

Abbreviation	Description
LL	Lossless (compression)
LLI	Lower Large Intestine
LY	Lossy (compression)
MPPS	Modality Performed Procedure Step
MWL	Modality Worklist
N/A	not applicable
NEMA	National Electrical Manufacturers Association
NL	Nesting Level
O	Optional Key Attribute
PACS	Picture Archiving and Communication System
PDU	DICOM Protocol Data Unit
R	Required Key Attribute
RIS	Radiology Information System
RRDSR	Radiopharmaceutical Radiation Dose Structured Report
SC	Secondary Capture
SCP	DICOM Service Class Provider (DICOM Server)
SCU	DICOM Service Class User (DICOM client)
SOP	DICOM Service-Object Pair
SR	Structured Report
TID	Template ID
U	Unique Key Attribute
UC	Uncompressed
UID	Unique Identifier
ULI	Upper Large Intestine
USB	Universal Serial Bus
UTF-8	Unicode Transformation Format-8
VNAP	Value not always present
VT	Value Type
VR	Value Representation

3.7 References

[1] NEMA PS3 / ISO 12052, Digital Imaging and Communications in Medicine (DICOM) Standard, National Electrical Manufacturers Association, Rosslyn, VA, USA (available free at <https://www.dicomstandard.org/>)

[2] "Integrating the Healthcare Enterprise" [Online]. Available: <http://www.ihe.net>.

4 Networking

4.1 Implementation Model

Biograph Vision uses PETSyngo Software VG85A which is based on the common Syngo platform and Somaris/7, the software platform for CT products, which provides the described Network Services.

The Biograph Vision examination supports creating and storing of PET and CT Images as well as Radiation Dose SR and Secondary Capture Images, later sending them to remote nodes like workstations or Archiving Systems. Using the Storage Commitment Service, it can request safe keeping of previously stored instances from an Archiving system. Additionally, the Biograph Vision Software can query remote nodes, retrieve and store selected instances from that node. Furthermore, it can also receive DICOM objects from remote nodes and answer to query/retrieve requests from remote nodes. Instances of many other SOP Classes than the ones created can be received – and sent again later (see Table 1).

Using the Modality Worklist service, the Biograph Vision can query a HIS/RIS for scheduled procedures. Performed procedure status and other procedure data can be returned to the HIS/RIS using the Modality Performed Procedure Step (MPPS) Service. Furthermore, printing of color and grayscale images is supported. See following sections for an overview of Application Entities and their roles within Biograph Vision.

4.1.1 Application Data Flow

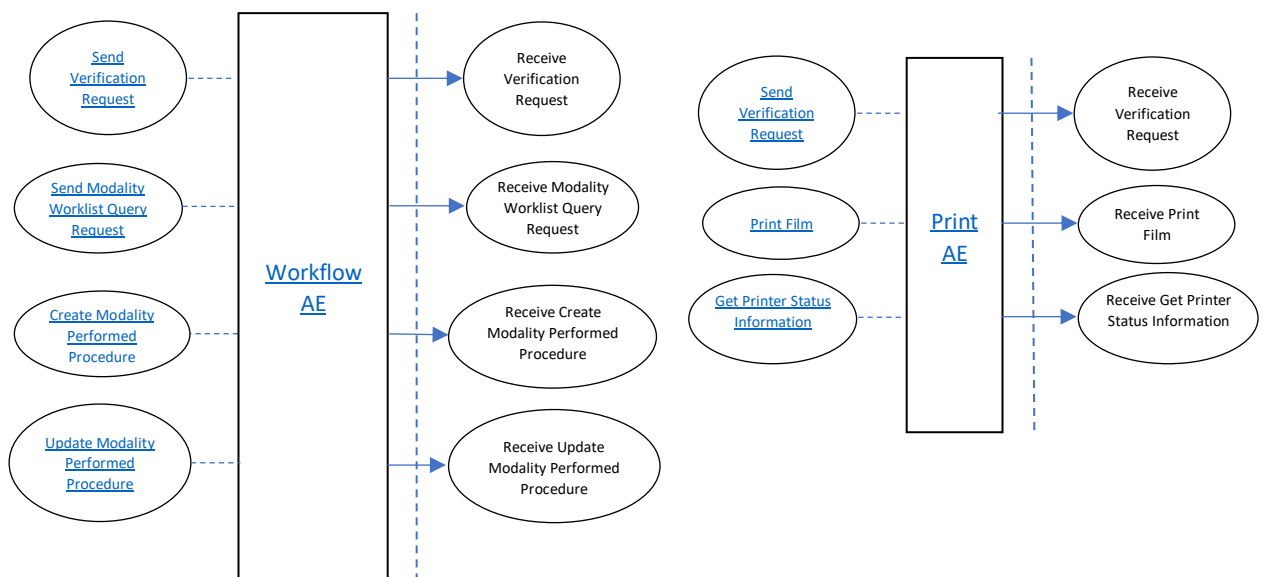
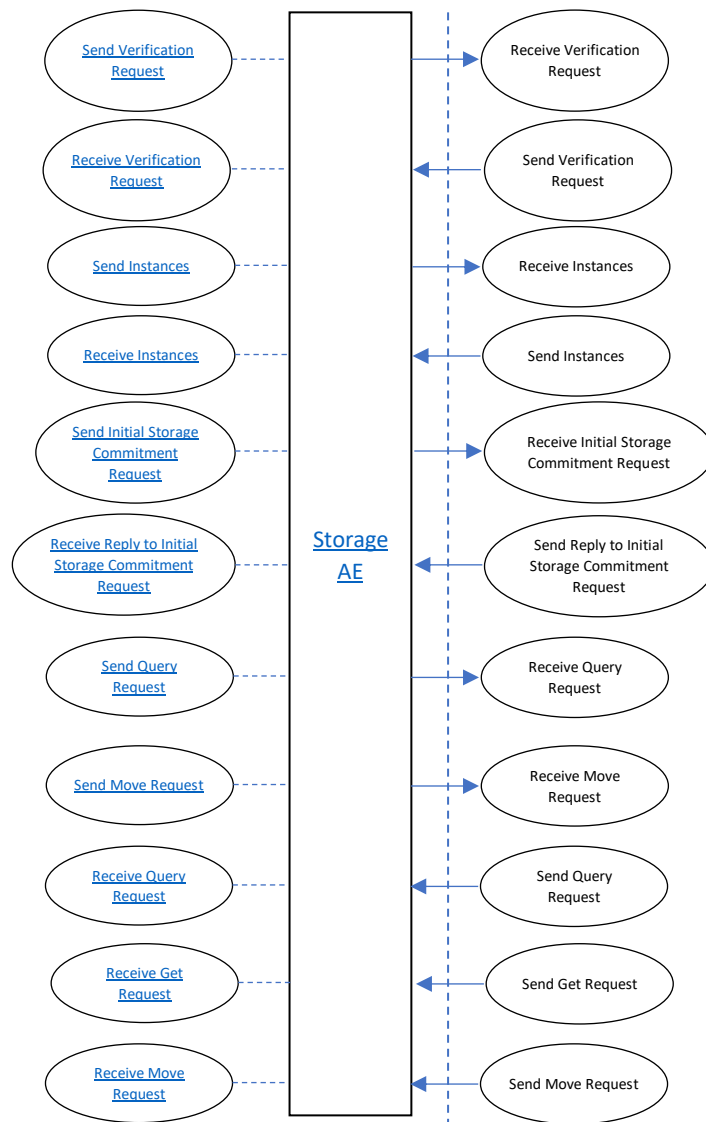

Figure 1: DICOM Data Flow diagram

4.1.2 Functional Definition of AEs

4.1.2.1 Functional Definition of Storage AE

The Biograph Vision Storage AE supports Verification as well as Storage, Storage Commitment (SCU only) and Query/Retrieve. See subsections below for details.

The Storage AE can be used for unencrypted communication and for encrypted communication; there is a separate AET for each way. Please see 4.4.1.1 and 8.1 for details of encrypted communication.

4.1.2.1.1 Verification

The Verification service class defines an application-level class of service which allows for the operator to verify the ability of an application on a remote node to respond to DICOM messages. The DICOM Service Tool User Interface provides access to the Verification service of the Storage AE acting as SCU.

The DICOM Service Tool application opens an association to an application on the remote node and sends a Verification message to verify that the remote application can respond to DICOM messages.

The other direction – responding to Verification requests from remote applications – is handled by the Storage AE acting as SCP within a background server process.

4.1.2.1.2 Storage

The Biograph Vision DICOM Storage AE both originates associations for Storage of DICOM Composite Information Objects in Remote Application Entities and accepts association requests for Storage from Remote Application Entities.

The Storage SCU is invoked by the job control interface that is responsible for processing network archiving tasks. The job consists of data describing the composite image objects selected for storage and the destination. An association is negotiated with the destination application entity and the image data is transferred using the C-STORE DIMSE-Service. Status of the transfer is reported to the job control interface.

The Storage SCP component of the Storage AE is operating as background server process. It is existing when the machine is powered on and waits for Storage association requests. Upon accepting an association with a negotiated Presentation Context, it starts to receive the Composite Image Objects and imports them to local database.

4.1.2.1.3 Storage Commitment

The Storage Commitment service class defines an application-level class of service which facilitates the commitment to storage. It performs an additional task of commitment of composite objects apart from the network-based storage of images as defined by the Storage Service class. The Biograph Vision DICOM Storage AE implementation supports the Storage Commitment Push Model as SCU.

With each successfully completed send job to a remote AE configured for Storage Commitment, the Storage AE will create a Storage Commitment Push Model Identifier from the SOP Instances sent. Then a Storage Commit Request is triggered. Depending on configuration, the Storage AE will keep the association open for responses with a configurable time-out or closes the association and expects responses on a different association that has to be established by the remote Storage Commitment SCP.

The commitment status derived from the related trigger response will be indicated in the Status Flags of the related entity. It is possible to create triggers ("auto rules") from this event.

The Transaction UIDs of the pending commitment request are kept "open" for a configurable amount in time (default: 1h). If the "open time" for a pending commitment request has elapsed without a related response from the provider, the Transaction UID is removed, and the related entities are indicated as "commit failed".

In any case, commitment will only be requested for previously and successfully sent images.

4.1.2.1.4 Query/Retrieve

The query/retrieve service class defines an application-level class of services which facilitates the management of images and patient data against the well-defined information model of DICOM and allows a DICOM AE on one network node to retrieve images from a remote DICOM node or to request a remote DICOM AE to initiate a transfer of images to another DICOM AE. The Storage AE supports the query/retrieve services to act as SCU and SCP.

The query/retrieve SCU requests the remote query/retrieve SCP to perform a search and match to the keys specified in the request in order to display the results in the user interface. Depending on user action (Import) the query/retrieve SCU sends a C-MOVE DIMSE service to initiate a C-STORE sub-operation on the SCP to start an image transfer from the remote Storage SCU to the Biograph Vision DICOM Storage SCP.

The query/retrieve SCP responds to C-FIND DIMSE services from remote SCU applications. Depending on further remote request, a C-GET or a C-MOVE involves the Biograph Vision DICOM query/retrieve SCP application to initiate a C-STORE association (by triggering and parameterizing the own Storage SCU) to send image objects to a remote Storage SCP.

All components of the Biograph Vision DICOM query/retrieve SCP are operating as background server processes. They are existing when the machine is powered on and then respond to queries based on the records stored in its database.

Note: The query/retrieve SCU of the Storage AE will execute new queries based upon the data found in the higher-level query. For details see Section 4.2.1.3.5.

4.1.2.2 Functional Definition of Print AE

4.1.2.2.1 Print

The Print Management Service Classes define an application-level class of services which facilitates the printing of images on a hardcopy medium. The print management SCU and print management SCP are peer DICOM print management application entities. The DICOM Print AE supports the print management DIMSE services to act as SCU.

The Print SCU is invoked by the user interface to set up film sheet layout and whenever an image is ready to be printed on film. The print SCU will hold and maintain all data needed to compile a complete film sheet from the data (images, layout, configuration) received. Whenever a film sheet is ready to print, the related data is used to supply the information to the SOP Classes of the Print Management Service Class. A queue is being maintained in order to intermediately store several film sheets in case of resource problems on printer. The SCU will only supply and require the mandatory SOP Classes of the Print Management Service Class.

4.1.2.3 Functional Definition of Workflow AE

The Biograph Vision Workflow AE supports Modality Worklist as well as Modality Performed Procedure Step, both as SCU. See subsections below for details.

4.1.2.3.1 Modality Worklist

The Basic Worklist Management Service Class defines an application-level class of service which facilitates the transfer of worklists from the information system to the imaging modality. The worklist is queried by the Workflow AE and supplies the SCU with the scheduled tasks, which have to be performed on the modality. The DICOM Workflow AE supports the worklist service as SCU.

Note: It is configurable to get the worklist updates either automatically (in a configurable time interval) or manually (initiated by the user). There are two kinds of queries the user can do: broad worklist query (all jobs for the own modality or own application entity) and patient-based worklist query (where more search keys can be given, including Patient's Name and Patient ID).

The worklist SCU ("broad query") is invoked from the patient browser user interface or by timer to request the worklist from a remote Information System (Modality Worklist SCP). This is done to perform a match to the internal worklist query keys specified in the C-FIND DIMSE service issued for the Modality Worklist Model.

The remote Worklist SCP responds to the C-FIND query and scheduled imaging service requests (scheduled procedure steps) and patient demographic information will be downloaded from the information system to the Biograph Vision modality. All information retrieved will be held in the scheduling database for usage during patient registration procedure.

Furthermore, the patient based query dialog from the patient browser allows to enter specific matching criteria ("narrow query") for the issue worklist query. With the response data the Patient Registration dialog can be populated according to availability within the worklist response identifier.

4.1.2.3.2 Modality Performed Procedure Step

The Modality Performed Procedure Step SOP Class defines an application-level class of service which facilitates the status update of procedure to a RIS, as an example. There is also a means to report billing information from the imaging modality to the information system; in order to keep behavior of previous SW versions, implementation for radiation dose information is retained (although retired in current version of DICOM now). The performed procedure step is created and set by the AE and supplies the SCP with information about a real-world procedure which is performed on the modality. The DICOM Modality Performed Procedure Step application supports the MPPS service as SCU.

With registration of a patient (i.e., a Scheduled Procedure Step from Worklist), the Biograph Vision DICOM Workflow AE will create an MPPS instance and communicate it to the remote MPPS SCP.

Furthermore, a manual update can be performed with the Biograph Vision MPPS user interface. There it is possible to set the state of the MPPS to "Completed" or "Discontinued". If done, the DICOM application will no longer allow updates on the related MPPS Instance.

Biograph Vision will not only allow a "1:1 relationship" of Scheduled Procedure Steps and Performed Procedure Steps but also supports the "group case" (grouping several SPS of the same or different Requested Procedures) and "append case" from the respective IHE scenarios.

Biograph Vision supports creation of "unscheduled cases" by allowing MPPS instances to be communicated for locally registered patients.

4.1.2.3.2.1 Extensions to Modality Performed Procedure Step SOP Class

Although support for the Radiation Dose SR SOP Class is available with Biograph Vision, there is still support of the meanwhile retired Radiation Dose Module within the Modality Performed Procedure Step SOP Class. This is mainly for support of existing SCP implementations.

For details of extensions see the documentation in 4.2.3.3.3.3 for N-CREATE DIMSE and 4.2.3.3.4.3 for the N-SET DIMSE. Even the Radiation Dose Module itself has been extended in this context.

4.1.3 Sequencing of Real World Activities

4.1.3.1 Verification

Newly configured data of a remote AE have to be saved first, before a "verification" of these data is possible.

Sequence diagram is provided for Storage AE as an example, as it supports Verification as SCU and SCP.

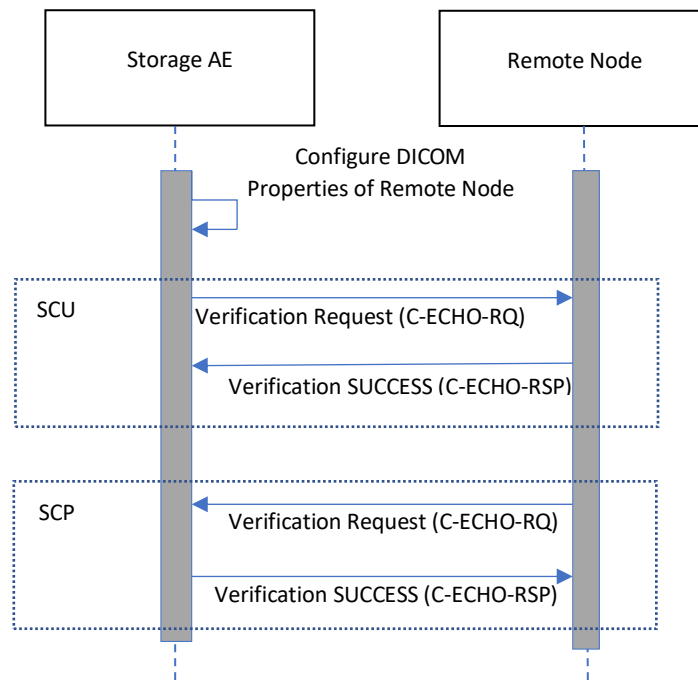

Figure 2: Sequence Diagram – Verification

4.1.3.2 Storage and Storage Commitment

The Storage Commitment trigger is automatically derived from the successful completion of a Send job, if the target node is configured correspondingly.

Sequence diagram is provided for Storage AE as an example.

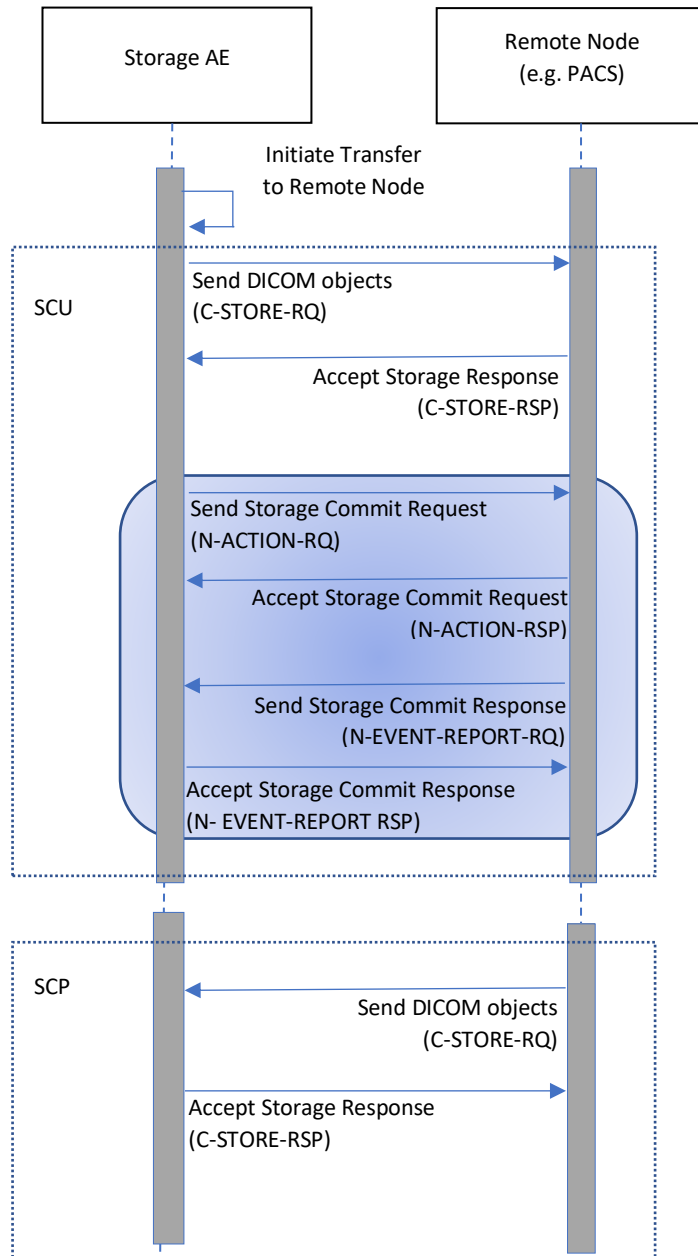

Figure 3: Sequence Diagram – Storage / Storage Commitment

4.1.3.3 Query/Retrieve

Retrieve of images is only possible if results from a previous "Search..." operation exist and those entities can be selected for "Import".

Sequence diagram is provided for Storage AE as an example.

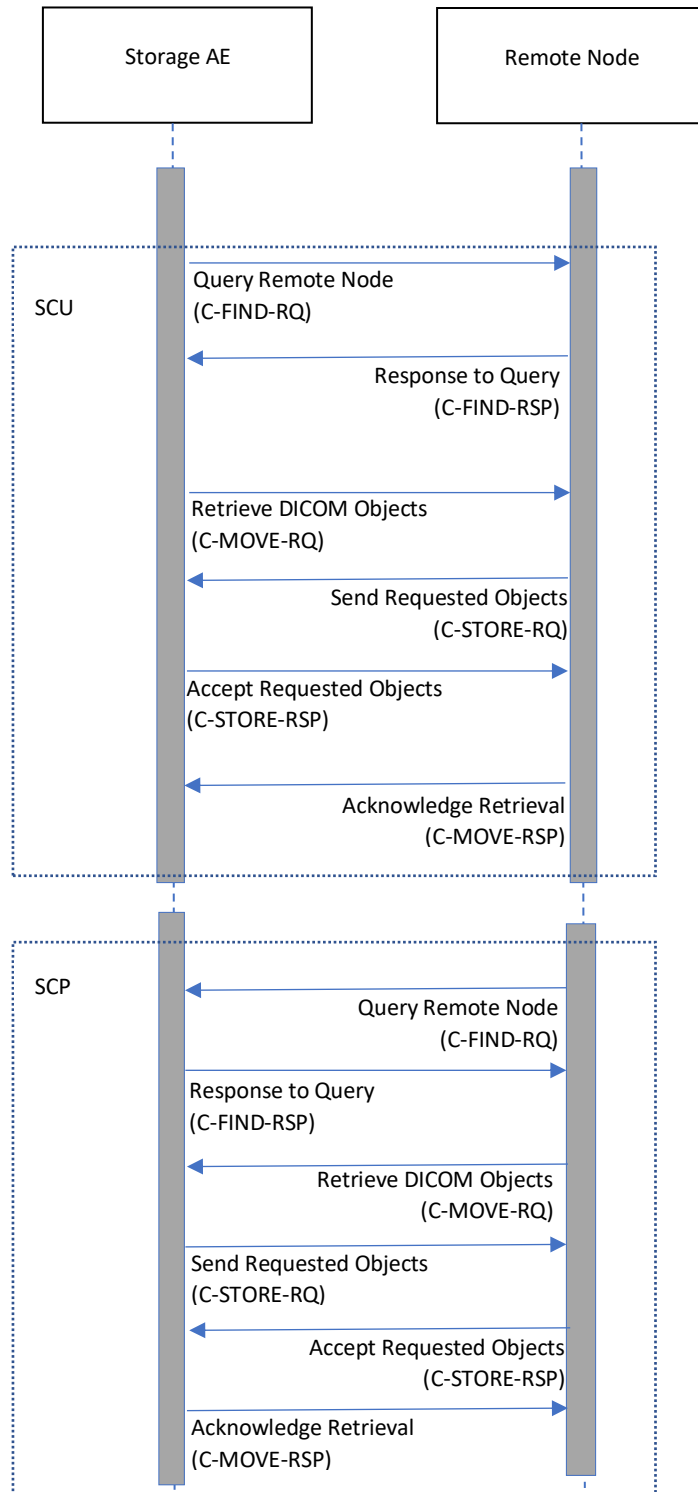
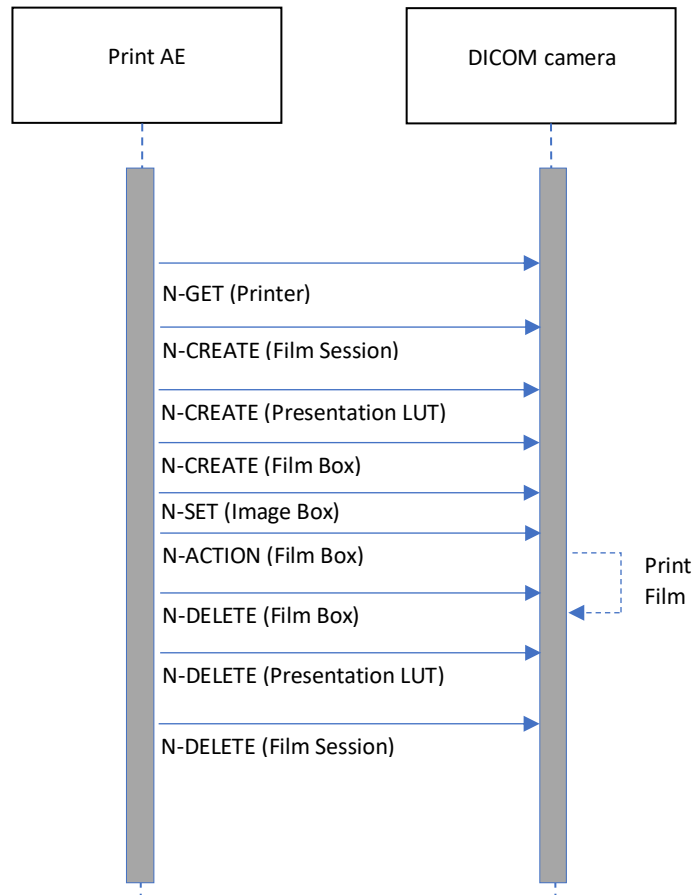

Figure 4: Sequence Diagram – Query / Retrieve

4.1.3.4 Printing Workflow

Sequence diagram is provided to illustrate printing of film sheet within Meta SOP Classes.



All events (arrows) stand for a request / response pair.

Figure 5: Sequence Diagram – Printing

4.1.3.5 Modality Worklist

The "narrow" (patient based) Worklist Query requires that sufficient matching keys or a unique matching key are/is entered before the query is issued. Only then a single response can be expected to complete the registration dialog.

Sequence diagram is provided for Storage AE as an example, as it supports Verification as SCU and SCP.

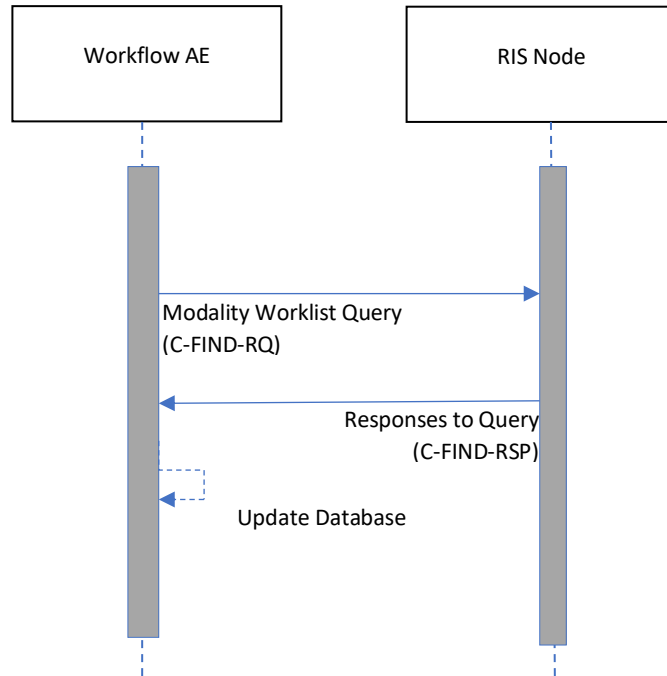
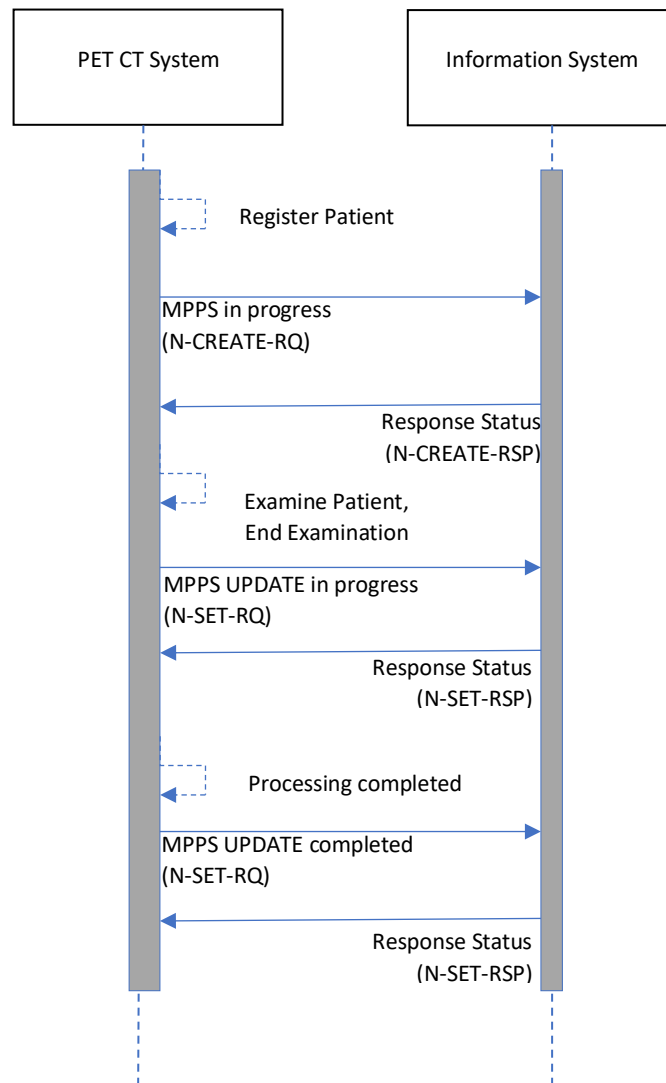

Figure 6: Sequence Diagram – Modality Worklist

4.1.3.6 Modality Performed Procedure Step

MPPS is created on Patient Registration. It is updated automatically when patient is closed in examination. Completion of the



MPPS is transmitted in a separate final step, e.g. after planned acquisition activities have finished.

Figure 7: Sequence Diagram – Modality Performed Procedure Step

4.2 AE Specifications

This section outlines the specifications for each of the Application Entities that are part of the Biograph Vision software.

4.2.1 Storage AE Specification

The Biograph Vision Storage service class user applications and service class provider applications use one AE when initiating/receiving associations unencrypted to/from remote DICOM nodes.

4.2.1.1 SOP Classes

The Storage AE implementation provides Standard Conformance to the DICOM SOP Class "Verification" as both an SCU and SCP.

The Storage AE implementation provides Standard Conformance to the DICOM SOP Classes listed in section "Transfer" of Table 1: Network Services of the Conformance Statement Overview as both an SCU and SCP.

The Storage AE provides Standard Conformance to the DICOM SOP Class "Storage Commitment Push Model" as an SCU, as listed in "Table 1: Network Services" section "Workflow" of the Conformance Statement Overview.

The Storage AE provides Standard Conformance to the DICOM SOP Classes as listed explicitly in "Table 1: Network Services" section "Query/Retrieve" of the Conformance Statement Overview.

4.2.1.2 Association Policy

4.2.1.2.1 General

The Storage AE attempts to open an association for verification request whenever the "verification" function is activated during network configuration of a remote DICOM application.

For transfer of objects, the Storage AE will be triggered by the transfer job queue or by an external retrieve request. An association request is sent to the destination AE, and, upon successful negotiation of a Presentation Context, the transfer is started. Depending on configuration, processing, or resizing can be applied to the images prior to being sent.

With a Send Job successfully completed, the Storage AE will – if configured – generate the Storage Commitment Request Information which references all Instances of the processed job. The Commit Request is sent over a single open association. The Storage AE will wait for Status responses of the Storage Commitment Request. If the Provider accepts the Storage Commitment with Success Status, the generated Transaction UID, together with study identification data and a timestamp, is kept. Depending on configuration, the association is closed or kept open for a configured time range. If the association is closed immediately, the response is expected on a different association which is the default setting. Multiple Storage Commitment Requests can be pending.

The Storage AE will accept any number of verification or storage SOP Classes that are referred to above. There is no limit on the number of presentation contexts accepted except for the DICOM limit. If the Storage AE runs out of resources, it will reject the association request.

With the "Search..." function the query data are entered and the DICOM Query/Retrieve is started. A query request will be sent out to one remote node that can be selected from a list of configured Query Providers and the response data will be displayed for the user. In order to provide detailed information early, additional queries are sent for the more detailed levels not yet covered by the first results. Upon request (Import), the retrieval of selected items is initiated.

When "trusted host functionality" is enabled Storage AE will only accept Associations from known hosts with a known AET. Hosts and AETs must be entered in "Local Service" by a Siemens CSE.

The default PDU size will be 32KB.

4.2.1.2.2 Number of Associations

When triggered from the Biograph Vision Service UI for Verification, the Storage AE initiates one association at a time to request verification.

For sending of objects and Storage Commitment, the Storage AE initiates several associations at a time, one for each destination to which a transfer request is being processed in the active job queue list.

For receiving of objects and separate Storage Commitment notifications, the Storage AE is able to accept multiple associations at a time. It can handle up to 10 associations in parallel.

For Query it initiates a new association to the remote node and issues the C-FIND request to retrieve all the requested patient and study information matching the search criteria. All the subsequent calls for C-FIND to obtain information on sub-studies and sub-series run in parallel i.e., multiple associations are being initiated to the remote node for C-FIND requests. It can handle up to 10 associations in parallel.

For the Retrieve request (C-MOVE) only one association is initiated per destination.

The number of simultaneous DICOM associations can be configured via the Service-UI. The dialog can be found in Configuration / DICOM / General.

4.2.1.2.3 Asynchronous Nature

For Verification, the Storage AE does not support asynchronous communication (multiple outstanding transactions over a single association).

The Storage AE supports sending/receiving of the DICOM objects in asynchronous mode during network transfers. The asynchronous mode allows the user to specify a window size i.e., Max Operations Invoked and Max Operations Performed for both SCU and SCP. The window size defines, the number of request messages can be sent/received over an association before a response message is required to be received.

Note: As this is optional configuration, the asynchronous communication configuration features can be enabled through the service UI in Configuration / DICOM / General for the local machine, and in DICOM/Network Nodes page for Remote machines.

For Query/Retrieve the Storage AE does not support asynchronous communication (multiple outstanding transactions over a single association).

4.2.1.2.4 Implementation Identifying Information

The Biograph Vision software is using common Implementation Identifying Information for all network related AEs.

For detailed Application Context Name, Implementation Class UID and Implementation Version Name please refer to common Table 3: Implementation Identifying Information in the "Conformance Statement Overview".

4.2.1.3 Association Initiation Policy

4.2.1.3.1 Activity – "Send Verification Request"

4.2.1.3.1.1 Description and Sequencing of Activities

Triggered by the Biograph Vision Service UI, the Storage AE attempts to initiate a new association for

- DIMSE C-ECHO

Service operation.

The Storage AE serves as SCU of the Verification Service Class. A C-ECHO-RQ is initiated by the Service and Configuration SW environment whenever a "Verification" is requested. If an association to a remote Application Entity is successfully established, Verification with the configured AET is requested via the open association. If the C-ECHO Response from the remote Application contains a status other than "Success" this will be indicated in the service environment and the association is closed.

4.2.1.3.1.2 Proposed Presentation Contexts

The Storage AE will propose a Presentation Context as shown in the following table:

Table 6: Presentation Context for Storage AE

Abstract Syntax		Transfer Syntax		Role	Extended Negotiation
Name	UID	Name List	UID List		
Verification	1.2.840.10008.1.1	Implicit VR Little Endian	1.2.840.10008.1.2	SCU	None
		Explicit VR Little Endian	1.2.840.10008.1.2.1		
		Explicit VR Big Endian	1.2.840.10008.1.2.2		

4.2.1.3.2 SOP specific Conformance for SOP Classes

The Storage AE conforms to the definition of a Verification SCU in accordance with the DICOM Standard.

4.2.1.3.3 Activity – “Send Instances”

4.2.1.3.3.1 Description and Sequencing of Activities

If a job with network destination gets active in the job list or a retrieve sub-operation is processed, Storage AE attempts to initiate a new association for

- DIMSE C-STORE to send images

The associated Real-World activities are:

The C-STORE request is triggered by a job with network destination or the processing of an external C-MOVE retrieve request. If the process successfully establishes an association to a remote Application Entity, it will transfer each image one after another via the open association. Processing features and resizing of the pixel matrix can be applied as part of the transfer. If the C-STORE Response from the remote Application contains a status other than “Success” or “Warning”, the association is aborted.

The flags A (Archived) and S (Sent) respectively will be set in the UI, depending on configuration of the remote node as archive node, when C-STORE Response from the remote Application contains a status of “Success” or “Warning”.

Note: The flags A (Archived) and S (Sent) respectively only indicate the receipt of the images by remote AE. They do not indicate successful storage in the intended node. The data may be lost if it is deleted by the sender e.g., by an auto delete mechanism and if it cannot be stored by the receiver.

4.2.1.3.3.2 Proposed Presentation Contexts

The DICOM application will propose Storage SCU Presentation Contexts as shown in the following table. Kindly refer Table 1 in chapter 1 [“Conformance Statement Overview”](#).

Table 7: Proposed Presentation Contexts for Storage AE

Abstract Syntax	Transfer Syntax		Role	Extended Negotiation
	Name List	UID List		
Any image SOP Class detailed in “Table 1 - Network Services” section „Transfer (Image SOP Class)“.	JPEG Baseline (Process 1): Default Transfer Syntax for Lossy JPEG 8 Bit Image Compression	1.2.840.10008.1.2.4.50	SCU	None
	JPEG Extended (Process 2 & 4): Default Transfer	1.2.840.10008.1.2.4.51		

Abstract Syntax	Transfer Syntax		Role	Extended Negotiation
Description	Name List	UID List		
	Syntax for Lossy JPEG 12 Bit Image Compression (Process 4 only)			
	JPEG Lossless, Non-Hierarchical, First-Order Prediction (Process 14 [Selection Value 1]): Default Transfer Syntax for Lossless JPEG Image Compression	1.2.840.10008.1.2.4.70		
	Explicit VR Little Endian	1.2.840.10008.1.2.1		
	Explicit VR Big Endian	1.2.840.10008.1.2.2		
	Implicit VR Little Endian	1.2.840.10008.1.2		
	RLE Lossless	1.2.840.10008.1.2.5		
	JPEG-LS Lossless Image Compression	1.2.840.10008.1.2.4.80		
Any Non-image SOP Class detailed in "Table 1 - Network Services" section „Transfer (Non-Image SOP Class)“.	Explicit VR Little Endian Explicit VR Big Endian Implicit VR Little Endian	1.2.840.10008.1.2.1 1.2.840.10008.1.2.2 1.2.840.10008.1.2	SCU	None
Private SOP Class as detailed in Chapter "Table 1 - Network Services" section „Transfer (Private SOP Class)“.	Explicit VR Little Endian Explicit VR Big Endian Implicit VR Little Endian	1.2.840.10008.1.2.1 1.2.840.10008.1.2.2 1.2.840.10008.1.2	SCU	None

Note:

1. If possible, images received with compression transfer syntax will be decompressed when stored locally. Transfer syntax when sending then may deviate.

2. The compression is only supported for images with pixel representation (0028, 0103) equal to 0 (=unsigned)

The "MOVE destinations" must be configured as Storage destinations. This would include the configuration of Transfer Syntax capabilities.

Not all the listed transfer syntaxes will be proposed all the time. For some abstract syntaxes only a list of uncompressed (UC) transfer syntaxes (one or more) will be proposed, for other abstract syntaxes also JPEG Lossless (LL) syntax will be proposed and/or a list of JPEG Lossy (LY) transfer syntaxes. The contents of this lists are configurable, e.g., UC could be configured to contain only Implicit Little Endian for instance.

Depending on the real-world activity initiating the C-STORE, we have the following behaviors:

- if the C-STORE is initiated by a user, a configuration parameter called Quality Factor(Q) will be used to decide which transfer syntax lists will be proposed. Q can take values between 0 and 100. If Q=0, only UC will be proposed. If Q = 100, UC and LL will be proposed. Else UC and LY will be proposed.
- if the C-STORE is initiated by the C-MOVE SCP, there is another configuration parameter called Compression Types Supported (CTS) which will be used to decide what transfer syntaxes are proposed. CTS can take integer values. If CTS=0 or

CTS > 3, UC will be proposed. If CTS=1, UC and LY will be proposed. If CTS = 2, UC and LL will be proposed. If CTS >= 3, UC, LL and LY will be proposed.

The compression types of JPEG lossy and JPEG lossless are parameters, which are part of the Application Entity Properties configuration (storage checked). It can be reached via the Service-UI: Configuration / DICOM / Network nodes.

4.2.1.3.3.3 SOP specific Conformance for SOP Classes

The Storage AE can send images in different formats. In a destination specific service level configuration, it can be configured if images are sent original, resized (512x512 8 bit, 1024x1024 12 bit) and/or processed.

For association and DIMSE level time-outs, please refer to section Configuration (Parameters) of this document.

Please refer to the related Image Object definition tables in the Annex (section “Created SOP Instance(s)”) for a list of all DICOM IOD attributes of type 2 and 3, which are encoded by the syngo applications.

The DICOM images sent by syngo DICOM application conform to the DICOM IOD definitions (Standard extended IODs). But they will contain additional private elements, which must be discarded by a DICOM system when modifying the image.

The DICOM nodes are responsible for data consistency when modifying images. All unknown private attributes must be removed upon modification!

Please refer to "Standard Extended/Specialized/Private SOP Classes" in the Annex for a list of possible private IOD attributes.

4.2.1.3.4 Activity – “Send Initial Storage Commitment Request”

4.2.1.3.4.1 Description and Sequencing of Activities

With success status for the previous transfer to a target configured for Storage Commitment, the syngo Storage AE sends the commit request (N-ACTION-RQ) message and waits for acceptance of this request (N-ACTION-RSP). After receiving this, the transaction is marked as “waiting”.

Depending on a configuration value, the association will then be closed or kept open. For the first case, see corresponding subsequent activity in 4.2.1.4.3. In the second case, which is in focus here, the association is kept open for a (configurable) time to receive the responses.

If the commit response (N-EVENT-REPORT) does not arrive within the configured time-out, the transaction will be marked as failed. For details of application-level behavior see 4.2.1.4.3.1

4.2.1.3.4.2 Proposed Presentation Contexts

The Storage Commitment AE will propose Presentation Contexts as shown in the following table:

Table 8: Proposed Presentation Context for Storage AE

Abstract Syntax		Transfer Syntax		Role	Extended Negotiation
Name	UID	Name List	UID List		
Storage Commitment Push Model	1.2.840.10008.1.20.1	Implicit VR Little Endian	1.2.840.10008.1.2	SCU	None
		Explicit VR Little Endian	1.2.840.10008.1.2.2		
		Explicit VR Big Endian	1.2.840.10008.1.2.1		

4.2.1.3.4.3 SOP specific Conformance for SOP Classes

Storage Commitment is supported for all the SOP Class UIDs as mentioned in Table 1: Network Services, sections Transfer.

The Referenced Study Component Sequence is not supported.

Storage Media File-Set ID and UID Attributes will not be supported in the commitment request (N-ACTION primitive) invoked by the Storage Commitment SCU.

4.2.1.3.5 Activity – “Send Query Request”

4.2.1.3.5.1 Description and Sequencing of Activities

The associated Real-World activity is to fill out a query form with search data and pass it as queries to the network application which issues a C-FIND over a previously built association. The remote SCP will respond with related data entries that will be passed to a browser application. When data transfer is finished the association is closed.

4.2.1.3.5.2 Proposed Presentation Contexts

The Biograph Vision DICOM Query application will propose Presentation Contexts as shown in the following table

Table 9: Proposed Presentation Contexts for Storage AE

Abstract Syntax		Transfer Syntax		Role	Extended
Name	UID	Name List	UID List		Negotiation
Patient Root Query/Retrieve Information Model - FIND	1.2.840.10008.5.1.4 .1.2.1.1	Implicit VR Little Endian Transfer Syntax	1.2.840.10008.1.2	SCU	None
		Explicit VR Little Endian Transfer Syntax	1.2.840.10008.1.2.1		
		Explicit VR Big Endian Transfer Syntax	1.2.840.10008.1.2.2		
Study Root Query/Retrieve Information Model - FIND	1.2.840.10008.5.1.4 .1.2.2.1	Implicit VR Little Endian Transfer Syntax	1.2.840.10008.1.2	SCU	None
		Explicit VR Little Endian Transfer Syntax	1.2.840.10008.1.2.1		
		Explicit VR Big Endian Transfer Syntax	1.2.840.10008.1.2.2		
Patient Study Only Query/Retrieve Information Model - FIND	1.2.840.10008.5.1.4 .1.2.3.1	Implicit VR Little Endian Transfer Syntax	1.2.840.10008.1.2	SCU	None
		Explicit VR Little Endian Transfer Syntax	1.2.840.10008.1.2.1		
		Explicit VR Big Endian Transfer Syntax	1.2.840.10008.1.2.2		

Note:

Within the DICOM network configuration it is configurable which of the query models are to be used by the syngo DICOM Query SCU application for each node. If Patient and Study Root Abstract Syntaxes are configured, the Find SCU will use the Patient Root Information Model only for C-FIND requests on PATIENT level. For all other levels it will use the Study Root Information model.

4.2.1.3.5.3 SOP specific Conformance for SOP Classes

The Biograph Vision DICOM Query/Retrieve SCU supports hierarchical queries with all mandatory search keys. The interactive querying of attributes on IMAGE level is not supported by the Query SCU, hence retrieval of individual Objects is not possible. The following table describes the search keys for the different query models that the SCU supports. Matching is one of single value, range, wildcard (which means that the user can supply a string containing wildcard) or universal (which means that the attribute is requested as return value).

Table 10: C-FIND-RQ Search Keys

Attribute name	Tag	Type	Matching	User input	Return value displayed
Patient level¹					
Patient's Name	(0010,0010)	R	Wildcard (see Note 1)	enter value	yes
Patient ID	(0010,0020)	U / R	Wildcard (see Note 1)	enter value	yes
Patient's Birth Date	(0010,0030)	O	Single Value	enter value	yes
Patient's Sex	(0010,0040)	O	Single Value	enter value	yes
Number of Patient Related Studies	(0020,1200)	O	Universal (Null)	-	yes ²
Number of Patient Relates Series	(0020,1202)	O	Universal (Null)	-	no
Number of Patient Related Instances	(0020,1204)	O	Universal (Null)	-	no
Study level					
Patient's Name ³	(0010,0010)	R	Wildcard (see Note 1)	enter value	yes
Patient ID	(0010,0020)	U / R	Wildcard (see Note 1)	enter value	yes
Patient's Birth Date ¹	(0010,0030)	O	Single Value	enter value	yes
Patient's Sex ¹	(0010,0040)	O	Single Value	enter value	yes
Study Instance UID	(0020,000D)	U	Single Value	-	no
Study ID	(0020,0010)	R	Wildcard (see Note 1)	enter value	yes
Study Date	(0008,0020)	R	Range	enter value ⁴	yes
Study Time	(0008,0030)	R	Range	enter value	yes
Accession Number	(0008,0050)	R	Wildcard	enter value	yes
Study Description	(0008,1030)	O	Wildcard (see Note 1)	enter value	yes
Referring Physician's Name	(0008,0090)	O	Wildcard (see Note 1)	enter value	yes
Name of Physician(s) Reading Study	(0008,1060)	O	Wildcard (see Note 1)	enter value	yes

¹ Only for Patient Root Information Model

² Implicitly visualized in the UI if no study and series search attributes have been entered

³ Only for Study Root information model

⁴ Date range possible

Attribute name	Tag	Type	Matching	User input	Return value displayed
Modalities in Study	(0008,0061)	O	Single Value	enter value	yes
Number of Patient Related Studies	(0020,1200)	O	Universal (Null)	-	no
Number of Patient Related Series	(0020,1202)	O	Universal (Null)	-	no
Number of Patient Related Instances	(0020,1204)	O	Universal (Null)	-	no
Number of Study Related Series	(0020,1206)	O	Universal (Null)	-	yes ¹
Number of Study Related Instances	(0020,1208)	O	Universal (Null)	-	no
Series level					
Series Instance UID	(0020,000E)	U	Single Value	enter value	yes
Series Number	(0020,0011)	R	Single Value	enter value	yes
Modality	(0008,0060)	R	Single Value	enter value	yes
Series Date	(0008,0021)	O	Universal (Null)	-	yes
Series Time	(0008,0031)	O	Universal (Null)	-	yes
Series Description	(0008,103E)	O	Wildcard (see Note 1)	enter value	yes
Body Part Examined	(0018,0015)	O	Single Value	enter value	yes
Performing Physician's Name	(0008,1050)	O	Wildcard (see Note 1)	enter value	yes
Request Attributes Sequence	(0040,0275)	O	-	-	yes
>Requested Procedure ID	(0040,1001)	O	Wildcard (see Note 1)	enter value	yes
>Scheduled Procedure Step ID	(0040,0009)	O	Wildcard (see Note 1)	enter value	yes
Performed Procedure Step Start Date	(0040,0244)	O	Range	enter value	yes
Performed Procedure Step Start Time	(0040,0245)	O	Range	enter value	yes
Number of Series Related Instances	(0020,1209)	O	Universal (Null)	-	yes
Instance Availability	(0008,0056)	O	Universal (Null)		
Image Level					
SOP Instance UID	(0008,0018)	U	Single Value	-	no
Instance Number	(0020,0013)	R	Universal (Null)	-	yes
SOP Class UID	(0008,0016)	O	Universal (Null)	-	no

¹ Implicitly visualized in the UI if no series search attributes have been entered

Attribute name	Tag	Type	Matching	User input	Return value displayed
Image Comments	(0020,4000)	O	Universal (Null)	-	yes
Number of Frames	(0028,0008)	O	Universal (Null)	-	yes
Content Date	(0008,0023)	O	Universal (Null)	-	yes
Content Time	(0008,0033)	O	Universal (Null)	-	yes

U = Unique Key, **R** = Required Key, **O** = Optional Key, - = not supported or applicable

Note 1: Always a "*" is appended to the user-supplied string

The Biograph Vision Search application supports a

- DIMSE C-CANCEL-FIND

if the user wishes to cancel a running Query request via the Biograph Vision user interface ("Cancel" button while a "Search..." is active).

The Query/Retrieve AE interprets following status codes:

Table 11: Status codes "Search"

Service Status	Meaning	Protocol Codes	Related Fields
Success	Matching is complete - No final Identifier is supplied	0000	None
Refused	Out of Resources	A700	(0000,0902)
Failed	Identifier does not match SOP Class	A900	(0000,0901) (0000,0902)
	Unable to process	Cxxx	(0000,0901) (0000,0902)
Cancel	Matching terminated due to Cancel request	FE00	None
Pending	Matches are continuing - Current Match is supplied and any Optional Keys were supported in the same manner as Required Keys	FF00	Identifier
	Matches are continuing - Warning that one or more Optional Keys were not supported for existence and/or matching for this identifier	FF01	Identifier

4.2.1.3.6 Activity – "Send Move Request"

4.2.1.3.6.1 Description and Sequencing of Activities

When selecting a data entry in the Query UI and activating the "Import" function, a retrieval request is passed to the Storage AE which issues a C-MOVE service according to the negotiated query model. (Activity – "Send Instances" describes the C-STORE service, which is generated by processing the C-MOVE service.)

The received image data are processed as described in the Storage class SCP descriptions.

The Storage AE will always insert its own AET as “Move Destination”.

4.2.1.3.6.2 Proposed Presentation Contexts

The Biograph Vision DICOM application will propose Presentation Contexts as shown in the following table:

Table 12: Proposed Presentation Contexts for Storage AE

Abstract Syntax		Transfer Syntax		Role	Extended
Name	UID	Name List	UID List		Negotiation
Patient Root Query/Retrieve Information Model - MOVE	1.2.840.10008.5.1.4.1.2.1.2	Implicit VR Little Endian Transfer Syntax	1.2.840.10008.1.2	SCU	See Note
		Explicit VR Little Endian Transfer Syntax	1.2.840.10008.1.2.1		
		Explicit VR Big Endian Transfer Syntax	1.2.840.10008.1.2.2		
Study Root Query/Retrieve Information Model - MOVE	1.2.840.10008.5.1.4.1.2.2.2	Implicit VR Little Endian Transfer Syntax	1.2.840.10008.1.2	SCU	See Note
		Explicit VR Little Endian Transfer Syntax	1.2.840.10008.1.2.1		
		Explicit VR Big Endian Transfer Syntax	1.2.840.10008.1.2.2		
Patient Study only Query/Retrieve Information Model - MOVE	1.2.840.10008.5.1.4.1.2.3.2	Implicit VR Little Endian Transfer Syntax	1.2.840.10008.1.2	SCU	See Note
		Explicit VR Little Endian Transfer Syntax	1.2.840.10008.1.2.1		
		Explicit VR Big Endian Transfer Syntax	1.2.840.10008.1.2.2		

Note: C-MOVE Extended Negotiation will be NOT supported by the SCU.

4.2.1.3.6.3 SOP specific Conformance for SOP Classes

All required keys will be provided in the retrieve request identifier, as defined in DICOM Standard.

The Move SCU interprets following status codes:

Table 13: C-MOVE (response) status codes

Service Status	Meaning	Protocol Codes	Related Fields
Success	Sub-operations Complete - No Failures or Warning	0000	(0000,1020) (0000,1021) (0000,1022) (0000,1023)
Refused	Out of Resources - Unable to calculate number of matches	A701	(0000,0902)
	Out of Resources - Unable to perform sub operations	A702	(0000,1020) (0000,1021) (0000,1022) (0000,1023)
	Move destination unknown	A801	(0000,0902)
Failed	Identifier does not match SOP Class	A900	(0000,0901) (0000,0902)
	Unable to process	Cxxx	(0000,0901) (0000,0902)
Cancel	Sub-operations terminated due to Cancel Indication	FE00	(0000,1020) (0000,1021) (0000,1022) (0000,1023)
Warning	Sub-operations Complete - One or more Failures of Warnings	B000	(0000,1020) (0000,1021) (0000,1022) (0000,1023)
Pending	Sub-operations are continuing	FF00	(0000,1020) (0000,1021) (0000,1022) (0000,1023)

4.2.1.4 Association Acceptance Policy

Please see Table 57 for AET and port number for association.

Associations will be rejected temporarily, when the network has been detected temporarily suspended/busy or when the maximum number of open associations has been reached. Associations will be rejected permanently when the calling AET is not trusted.

4.2.1.4.1 Activity – “Receive Verification Request”

4.2.1.4.1.1 Description and Sequencing of Activities

The Storage AE serves as an SCP of the Verification Service Class. If the Verification SCP accepts an association, it will respond to C-ECHO-RQs. If the Called AE Title does not match any pre-configured AE Title shared by SCP, the association will be rejected.

4.2.1.4.1.2 Accepted Presentation Contexts

The Storage AE will accept Presentation Contexts as shown in the following table:

Table 14: Acceptable Presentation Contexts for Storage AE and “Receive Verification Request”

Abstract Syntax		Transfer Syntax		Role	Extended Negotiation
Name	UID	Name List	UID List		
Verification	1.2.840.10008.1.1	Implicit VR Little Endian	1.2.840.10008.1.2	SCP	None
		Explicit VR Little Endian	1.2.840.10008.1.2.1		
		Explicit VR Big Endian	1.2.840.10008.1.2.2		

Acceptance of Presentation Context is depending on the proposal of the SCU. As Transfer Syntax Selection Policy, for a supported Abstract Syntax the first supported Transfer Syntax supported is taken from list of proposals and accepted.

4.2.1.4.1.3 SOP specific Conformance for SOP Classes

The Storage AE provides standard conformance to the Verification Service Class.

4.2.1.4.2 Activity – “Receive Instances”**4.2.1.4.2.1 Description and Sequencing of Activities**

The Storage AE will accept an association and will receive SOP Instances according to the listed presentation contexts on that association and will store the images to the local hard disk if the conformance check is performed successfully.

4.2.1.4.2.2 Accepted Presentation Contexts

The Biograph Vision DICOM application will accept Presentation Contexts as shown in the following table. Kindly refer Table 1 in “Conformance Statement Overview” for details:

Table 15: Acceptable Presentation Contexts for Storage AE and "Receive Instances"

Abstract Syntax	Transfer Syntax		Role	Extended Negotiation
Description	Name List	UID List		
Any image SOP Class detailed in "Table 1 - Network Services" section „Transfer“.	JPEG Lossy Extended (Process 2 & 4)	1.2.840.10008.1.2.4.51	SCP	None
	JPEG Lossless, Process 14 (selection value 1)	1.2.840.10008.1.2.4.70		
	JPEG Lossless, Non-Hierarchical (Process 14)	1.2.840.10008.1.2.4.57		
	JPEG Lossy Baseline (Process 1)	1.2.840.10008.1.2.4.50		
	RLE Lossless	1.2.840.10008.1.2.5		
	Explicit VR Little Endian	1.2.840.10008.1.2.1		
	Explicit VR Big Endian	1.2.840.10008.1.2.2		
	Implicit VR Little Endian	1.2.840.10008.1.2		
	JPEG 2000 Lossless	1.2.840.10008.1.2.4.90		
	JPEG 2000 Lossy	1.2.840.10008.1.2.4.91		
JPEG LS LOSSLESS	1.2.840.10008.1.2.4.80			
Any non-image SOP Class detailed in "Table 1 - Network Services" section „Transfer“.	Explicit VR Little Endian	1.2.840.10008.1.2.1	SCP	None
	Explicit VR Big Endian	1.2.840.10008.1.2.2		
	Implicit VR Little Endian	1.2.840.10008.1.2		
Private SOP Class as detailed in Chapter "Table 1 - Network Services" section „Transfer“.	Explicit VR Little Endian	1.2.840.10008.1.2.1	SCP	None
	Explicit VR Big Endian	1.2.840.10008.1.2.2		
	Implicit VR Little Endian	1.2.840.10008.1.2		

Note:

1. The retired "Ultrasound Image Storage (Retired)" and "Ultrasound Multi-frame Image Storage (Retired)" are converted to the non-retired "Ultrasound Image Storage" resp. "Ultrasound Multi-frame Image Storage" before storing them into the local database. The conversion creates new images, which implies new UIDs.
2. With RLE Lossless Transfer Syntax and JPEG Lossless, Process 14, Non-HIER Transfer Syntax the DICOM application will decompress the image before storing it into the database.
3. JPEG 2000 decompression supported only for import in connection with COSMOS workplace.

Acceptance of Presentation Context is depending on the proposal of the SCU. As Transfer Syntax Selection Policy, for a supported Abstract Syntax the first supported Transfer Syntax supported is taken from list of proposals and accepted. The list of supported Transfer Syntaxes within Presentation Contexts or Presentation Contexts with single Transfer Syntaxes is:

Table 16: List of supported Transfer Syntaxes

Number in List	DICOM Transfer Syntax
1	JPEG Lossy Extended
2	JPEG Lossless hierarchical
3	JPEG Lossy Baseline
4	RLE Lossless
5	Explicit VR Little Endian
6	Explicit VR Big Endian
7	Implicit VR Little Endian
8	JPEG 2000 Lossy
9	JPEG 2000 Lossless
10	JPEG Lossless Non-hierarchical
11	JPEG LS LOSSLESS

4.2.1.4.2.3 *SOP specific Conformance for SOP Classes*

The Biograph Vision application conforms to Storage Level 2 (Full).

Any Explicit VR Transfer Syntax is preferred to be used by the Storage SCU when sending Composite Image Instances to the Biograph Vision DICOM application.

If an image instance is received that is identified by a SOP Instance UID which is already used by an Instance stored in database, then the actual received image will be discarded. The existing Instance is not superseded.

Private attributes in sequence items will be removed during import into syngo.

Receiving of Enhanced CT and Enhanced MR images with concatenated data is not supported – it will fail on saving and object will not be present in the internal database. This is realized by checking the Concatenation UID (Tag ID: 0020, 9161) of Multi-Frame Functional Group, which will be set for Concatenated data.

After receiving the images of type Multi-frame Single Bit Secondary Capture Image, Multi-frame Grayscale Byte Secondary Capture Image, Multi-frame Grayscale Word Secondary Capture Image and Multi-frame True Color Secondary Capture Image, the SOP Class UID of received image is changed and stored as Secondary Capture Image (1.2.840.10008.5.1.4.1.1.7). The SOP Class UID will be stored as private attribute and while sending it SOP Class UID will be updated back to original.

Images received with compression Transfer Syntax will be decompressed before storing into the database.

With Implicit VR Little Endian Transfer Syntax, the Biograph Vision DICOM application will remove any Private Attributes not known to the application. Decision on removal of a Private Element is done if there is NO entry in the attribute-dictionary of the Biograph Vision DICOM application.

Therefore, any Explicit VR Transfer Syntax shall preferably be used by the Storage SCU's when sending Composite Image Instances to the Biograph Vision DICOM application.

Upon successfully receiving a C-STORE-RQ, the Storage AE receiver performs a check for valid DICOM object on the received image and available system resources. If this test succeeds, it returns the Status SUCCESS, otherwise one of the following status codes is returned and the association is aborted:

Table 17: Status codes "Receive Instances"

Code	Meaning
A700	Refused: This error status indicates a lack of Resources (e.g., not enough disk space) on the Biograph Vision modality.
A900	Invalid Dataset: An error occurred while processing the image, which makes it impossible to proceed. The image will not be stored, and the association is aborted.
0110	Processing Error: An error occurred while processing the image, which makes it impossible to proceed. Association is aborted.

Note: The image will be saved after sending the response. If during this operation an error occurs, the association will be aborted. This implies that a C-STORE-RSP with status SUCCESS does not mean that the image was successfully stored into the database.

The following sections will differentiate the attribute contents required for Image Viewing. The Biograph Vision DICOM application supports more formats for Storage of Images than for Viewing.

4.2.1.4.2.3.1 *Image Pixel Attribute Acceptance Criterion for Grayscale Images*

The Biograph Vision Multi-Modality Viewing application accepts the MONOCHROME1 and MONOCHROME2 photometric interpretation pixel format and graphic overlay with unsigned integer and 8 or 16 bits allocated. Accepted values:

Pixel plane

1. Samples per Pixel (0028,0002) = 1
2. Photometric Interpretation (0028,0004) = "MONOCHROME1"
3. Photometric Interpretation (0028,0004) = "MONOCHROME2"
4. Pixel Representation (0028,0103) = 0
5. Bits Allocated (0028,0100) = 8, 16
6. Bits Stored (0028,0101) = 8, 10, 12, 14, 15, 16
7. High Bit (0028,0102) = 7, 9, 11, 13, 14, 15
8. only Pixel Aspect Ratio (0028,0034) of 1:1 is supported

Overlay plane

9. Overlay Type (60xx,0040) = "G"
10. Bits Allocated (60xx,0100) = 16
11. Bit Position (60xx,0102) = 12, 13, 14, 15 (only bits above high bit permitted)
12. Graphic Overlay will be shifted to fill Overlay Planes from Bit 12 and consecutive.

Overlay plane

13. Overlay Type (60xx,0040) = "G"
14. Bits Allocated (60xx,0100) = 1
15. Bit Position (60xx,0102) = 0
16. Overlay Data (60xx,3000) = supported

The Biograph Vision Multi-Modality Viewing application accepts also the MONOCHROME1 and MONOCHROME2 photometric interpretation pixel format with binary 2's complement integer and 16 bits allocated. Accepted values:

Pixel plane

- Samples per Pixel (0028,0002) = 1
- Photometric Interpretation (0028,0004) = "MONOCHROME1"

- Photometric Interpretation (0028,0004) = "MONOCHROME2"
- Pixel Representation (0028,0103) = 1 (signed)
- Bits Allocated (0028,0100) = 16
- Bits Stored (0028,0101) = 16
- High Bit (0028,0102) = 15
- only Pixel Aspect Ratio (0028,0034) of 1:1 is supported

Overlay plane

- Overlay Type (60xx,0040) = "G"
- Bits Allocated (60xx,0100) = 1
- Bit Position (60xx,0102) = 0
- Overlay Data (60xx,3000) = supported
- For MOD LUT, both the linear LUT (Rescale Slope/Intercept) and the MOD LUT SQ are supported and considered when pixel data is displayed. However, there are two limitations. The MOD LUT SQ will be ignored in the following cases:
 - 8-Bit signed pixels
 - the pixel format is changed by the MOD LUT (e.g., 8bit -> 16bit)

If the MOD LUT SQ contains multiple LUTs, then only the first one is used.

For VOI LUT, both the linear LUT (Window Center/Width) and the VOI LUT SQ are supported (VOI LUT SQ with 8- or 16-bit LUT data)

But if both, a VOI LUT SQ and a linear MOD LUT, are specified within one image, then the value for Rescale Slope is restricted to 1.

If the VOI LUT SQ contains multiple LUTs, then only the first one is used by default. The other VOI LUTs is selectable.

Only Rectangular and Circular Shutter Shape is supported in this version. Images containing other Shutter Shapes will be displayed w/o shutter.

4.2.1.4.2.3.2 *Image Pixel Attribute Acceptance Criterion for Color Images Viewing*

The Biograph Vision Multi-Modality Viewing application supports the RGB color image description with the unsigned integer 24-bit color image plane pixel format. Accepted values:

- Samples per Pixel (0028,0002) = 3
- Photometric Interpretation (0028,0004) = "RGB"
- Pixel Representation (0028,0103) = 0
- Bits Allocated (0028,0100) = 8
- Bits Stored (0028,0101) = 8
- High Bit (0028,0102) = 7
- Planar Configuration (0028,0006) = 0 (pixel interleave) or 1 (plane interleave).

The Biograph Vision Multi-modality Viewing application supports the "Palette Color" color image description with the unsigned integer and 2's complement pixel format. Accepted values:

- Samples per Pixel (0028,0002) = 1
- Photometric Interpretation (0028,0004) = "PALETTE COLOR"
- Pixel Representation (0028,0103) = 0
- Bits Allocated (0028,0100) = 8 and Bits Stored (0028,0101) = 8
- Bits Allocated (0028,0100) = 16 and Bits Stored (0028,0101) = 16

- High Bit (0028,0102) = 7, 15
- Both 8-bit and 16-bit palettes are supported, but NO Segmented Palette Color LUTs.

The Biograph Vision Multi-modality Viewing application supports the YBR color image description with the unsigned integer pixel format. Accepted values:

- Samples per Pixel (0028,0002) = 3
- Photometric Interpretation (0028,0004) = "YBR_FULL" or "YBR_FULL_422"
- Pixel Representation (0028,0103) = 0
- Bits Allocated (0028,0100) = 8 and Bits Stored (0028,0101) = 8
- High Bit (0028,0102) = 7

If Biograph Vision software is making any persistent changes on a YBR image, the resulting new image will be saved with Photometric Interpretation = "RGB".

4.2.1.4.3 Activity – "Receive Reply to Initial Storage Commitment Request"

4.2.1.4.3.1 Description and Sequencing of Activities

The Storage AE supports the reverse role negotiation of the Storage Commitment Service Class at the SCU. After having sent a Storage Commitment Request the Storage AE, if configured to receive response on a separate association, closes the association and waits for an association request from the Storage Commitment SCP that wants to send the results. There is a configurable timeout giving the number of hours (h) and minutes (m) (by default 1h:0m) to wait for the corresponding commit response (N-EVENT-REPORT).

Reaction to received Notifications will be the same, independent whether they are received on the same association (see 4.2.1.3.4) or on a different association, as in the current activity:

Any incoming Notification will be checked for validity, that is, if the related Transaction UID is still part of the Pending Request Queue.

If the Notification is valid the related Instances are marked with the reported status. The over-all Commit Status of the higher Information Entities in the syngo database is derived from propagation of the States of all sub-ordinate Image entities included in a study.

The Status Flags directly affected by Storage Commitment results and indicated in the different entities of the Patient Browser list can be one of.

- "AC" or "SC" - Successful Commitment, "A" means archived to configured Archive destination, whereas "S" means sent to any other destination.
- "Af" or "Sf" - Commitment failed.
- "A?" or "S?" - Commitment request is sent, response is pending.

In case of failure the user must repeat the transfer of images to the Archive destination. Another Storage Commitment will be performed after sending is completed successfully.

Note: The flags A (Archived) and S (Sent) respectively only indicate the receipt of the images by remote AE. They do not indicate successful storage in the intended archive. The data may be lost if it is deleted by the sender e.g., by an auto delete mechanism and if it cannot be stored by the receiver.

Advise the service technician always to use 'storage commitment' if supported by sender and receiver of data.

Source of danger: Misleading/misinterpretation of the flags AC/SC

Flags "AC"/ "SC" depict receipt and storage on hard disk on the receiver side which may be not sufficient to fulfill the regulatory requirements of long-term archiving.

Consequence: Loss of data within the required period for retention.

Remedy: Sending data with the attributes AC or SC via network indicates a safe data transfer but does not fulfill the regulatory requirements of long-term archiving. Objects with the “committed” flag may be deleted by the user. Observe the regulatory requirements regarding the archiving procedure.

4.2.1.4.3.2 Accepted Presentation Contexts

The Storage AE will accept Storage Commitment Presentation Contexts as shown in the following table:

Table 18: Acceptable Presentation Contexts for Storage AE and “Receive Reply to Initial Storage Commitment Request”

Abstract Syntax	Transfer Syntax		Role	Extended Negotiation	
	Description	Name List			UID List
1.2.840.10008.1.20.1 Storage Commitment Push Model		Implicit VR Little Endian	1.2.840.10008.1.2	SCU	None
		Explicit VR Little Endian	1.2.840.10008.1.2.1		
		Explicit VR Big Endian	1.2.840.10008.1.2.2		

Acceptance of Presentation Context is depending on the proposal of the SCU. As Transfer Syntax Selection Policy, for a supported Abstract Syntax the first supported Transfer Syntax supported is taken from list of proposals and accepted.

4.2.1.4.3.3 SOP specific Conformance for SOP Classes

If the Commitment response (N-EVENT-REPORT) received has the status of “complete - failure exists”, the transaction is marked as failed, else the transaction is marked as “completed”. In both cases, a message is shown to the user.

The related status flags are set for the committed images in the local database.

The syngo DICOM application will not support the Storage Media File Set ID attributes.

4.2.1.4.4 Activity – “Receive Query Request”

4.2.1.4.4.1 Description and Sequencing of Activities

The Storage AE will respond to incoming query requests from a SCU with the query model Patient Root, Study Root and Patient/Study Only. Relational retrieve operation is not supported. The content records of the local database are used to match the incoming query keys and fill the related return keys. With a C-CANCEL-FIND request the running query can be canceled at any time.

Multiple C-FIND requests over the same association are supported.

4.2.1.4.4.2 Accepted Presentation Contexts

The Biograph Vision Query/Retrieve AE will accept Presentation Contexts as shown in the following table

Table 19: Acceptable Presentation Contexts for Storage AE and “Receive Query Request”

Abstract Syntax		Transfer Syntax		Role	Extended Negotiation
Name	UID	Name List	UID List		
Patient Root Query/Retrieve Information Model - FIND	1.2.840.10008.5.1.4.1.2.1.1	Implicit VR Little Endian Transfer Syntax	1.2.840.10008.1.2	SCP	See Note
		Explicit VR Little Endian Transfer Syntax	1.2.840.10008.1.2.1		

Abstract Syntax		Transfer Syntax		Role	Extended Negotiation
Name	UID	Name List	UID List		
		Explicit VR Big Endian Transfer Syntax	1.2.840.10008.1.2.2		
Study Root Query/Retrieve Information Model - FIND	1.2.840.10008.5.1.4.1.2.2.1	Implicit VR Little Endian Transfer Syntax	1.2.840.10008.1.2	SCP	See Note
		Explicit VR Little Endian Transfer Syntax	1.2.840.10008.1.2.1		
		Explicit VR Big Endian Transfer Syntax	1.2.840.10008.1.2.2		
Patient/Study Only Query/Retrieve Information Model - FIND	1.2.840.10008.5.1.4.1.2.3.1	Implicit VR Little Endian Transfer Syntax	1.2.840.10008.1.2	SCP	See Note
		Explicit VR Little Endian Transfer Syntax	1.2.840.10008.1.2.1		
		Explicit VR Big Endian Transfer Syntax	1.2.840.10008.1.2.2		

Note: C-FIND Extended Negotiation will not be supported by the SCP.

Acceptance of Presentation Context is depending on the proposal of the SCU. As Transfer Syntax Selection Policy, for a supported Abstract Syntax the first supported Transfer Syntax supported is taken from list of proposals and accepted.

4.2.1.4.4.3 SOP specific Conformance for SOP Classes

The Biograph Vision DICOM Query/Retrieve SCP supports hierarchical queries with all mandatory and some optional search keys.

The following six notes apply to the handling of attribute Patient's Name (0010,0010) as Query/Retrieve SCP. The syntactical structure of Patient's Name (0010,0010) attribute is as follows:

<single byte group>=<ideographic group>=<phonetic group>

Each group may have up to five components, which are separated by carets "^".

1. Matching of Patient's Name attribute (0010,0010) is done case insensitive.
2. If a search string matches the complete value of a data base object's Patient's Name, a match will be returned.
3. If a search string matches an individual group (single byte, ideographic or phonetic) of a data base object's Patient's Name, a match will be returned.
4. If a search string matches two consecutive groups of a data base object's Patient's Name, a match will be returned.
5. Redundant group separators "=" or component separators "^" are treated as insignificant for matching.
6. Leading and trailing blanks within a component or a group of Patient's Name (0010,0010) are treated as insignificant for matching.

Except for the attribute Patient's Name (0010,0010) any other query attribute contents will be treated Case Sensitive.

With wildcard queries the symbol "?" is treated as "*" by the C-FIND-SCP application. As a consequence the query string of "?abc*" will be processed as "*abc*".

If the value for the patient level unique key "Patient ID" is not known, it may be returned with zero length. The attribute "Image Comments" will not be included in the C-FIND-RSP, if it is not set in the DB, even if it was requested as return key in the related C-FIND-RQ.

Usage of Storage Media File Set ID, Retrieve AE Title with C-FIND-RSP message:

- The C-FIND SCP may return the DICOM attributes StorageMediaFileSetID (0088,0130) and StorageMediaFileSetUID (0088,0140) as empty or not at all. The Storage Media File Set ID - if existent - can be returned at Study/Series/Image Level. Only on Image Level, the values of ONLINE, NEARLINE or OFFLINE are returned to indicate the Storage Location of the related instance.

- The C-FIND SCP may return the DICOM attributes Retrieve AE Title (0008,0054) as empty or not at all. The Retrieve AE Title - if existent - can only be returned at Image Level (for Patient Root Information and Study Root Information models) or Study Level (for Patient/Study Only Information model).

Relational Queries are NOT supported.

A remote DICOM AE can cancel the running query by sending a C-CANCEL-FIND. Matches are possibly continuing (more C-FIND response with status PENDING) until the cancel operation has completed.

The supported attributes on the various levels of the three information models are listed in the tables of the following sections.

Table 20: Query/Retrieve SCP supported attributes

Attribute name	Tag	PR	SR	PSo	Matching
Patient Level (PR or PSo) or Study Level (SR)					
Patient's Name	(0010,0010)	R	R	R	Single Value, Wildcard, Universal
Patient ID	(0010,0020)	U	R	U	Single Value, Wildcard, Universal
Patient's Birth Date	(0010,0030)	O	O	O	Single Value, Range, Universal
Patient's Birth Time	(0010,0032)	O	O	O	Single Value, Range, Universal
Patient's Sex	(0010,0040)	O	O	O	Single Value, Wildcard, Universal
Ethnic Group	(0010,2160)	O	-	O	Single Value, Wildcard, Universal
Patient Comments	(0010,4000)	O	O	O	Wildcard, Universal
Number of Patient Related Studies	(0020,1200)	O	O	O	Universal
Number of Patient Related Series	(0020,1202)	O	O	O	Universal
Number of Patient Related Instances	(0020,1204)	O	O	O	Universal
Study Level					
Study Instance UID	(0020,000D)	U	U	U	Single Value, List of UIDs
Study ID	(0020,0010)	R	R	R	Single Value, Wildcard, Universal
Study Date	(0008,0020)	R	R	R	Single Value, Range, Universal
Study Time	(0008,0030)	R	R	R	Single Value, Range, Universal

Attribute name	Tag	PR	SR	PSo	Matching
Accession Number	(0008,0050)	R	R	R	Single Value, Wildcard, Universal
Referring Physician's Name	(0008,0090)	O	O	O	Single Value, Wildcard, Universal
Study Description	(0008,1030)	O	O	O	Single Value, Wildcard, Universal
Admitting Diagnosis Description	(0008,1080)	O	O	O	Single Value, Wildcard, Universal
Patient's Age	(0010,1010)	O	O	O	Single Value, Wildcard, Universal
Patient's Size	(0010,1020)	O	O	O	Single Value, Universal
Patient's Weight	(0010,1030)	O	O	O	Single Value, Universal
Occupation	(0010,2180)	O	O	O	Single Value, Wildcard, Universal
Additional Patient History	(0010,21B0)	O	O	O	Wildcard, Universal
Name of Physician reading the Study	(0008,1060)	O	O	O	Single Value, Wildcard, Universal
Modalities in Study	(0008,0061)	O	O	O	Multiple values, Universal
Number of Study Related Series	(0020,1206)	O	O	O	Universal
Number of Study Related Instances	(0020,1208)	O	O	O	Universal
Series Level					
Series Instance UID	(0020,000E)	U	U	-	Single Value, List of UIDs
Series Number	(0020,0011)	R	R	-	Single Value, Universal
Modality	(0008,0060)	R	R	-	Single Value, Wildcard, Universal
Laterality	(0020,0060)	O	O	-	Single Value, Wildcard, Universal
Body Part Examined	(0018,0015)	O	O	-	Single Value, Wildcard, Universal

Attribute name	Tag	PR	SR	PSo	Matching
Patient Position	(0018,5100)	O	O	-	Single Value, Wildcard, Universal
Smallest Pixel Value in Series	(0028,0108)	O	O	-	Single Value, Universal
Largest Pixel Value in Series	(0028,0109)	O	O	-	Single Value, Universal
Protocol Name	(0018,1030)	O	O	-	Single Value, Wildcard, Universal
Series Date	(0008,0021)	O	O	-	Single Value, Range, Universal
Series Time	(0008,0031)	O	O	-	Single Value, Range, Universal
Series Description	(0008,103E)	O	O	-	Single Value, Wildcard, Universal
Operator's Name	(0008,1070)	O	O	-	Single Value, Wildcard, Universal
Performing Physician's name	(0008,1050)	O	O	-	Single Value, Wildcard, Universal
Performed Procedure Step Start Date	(0040,0244)	O	O	-	Universal
Performed Procedure Step Start Time	(0040,0245)	O	O	-	Universal
Number of Series related Instances	(0020,1209)	O	O	-	Universal
Image or SR Document Level					
SOP Instance UID	(0008,0018)	U	U	-	Single Value, List of UIDs
Image Number	(0020,0013)	R	R	-	Single Value, Universal
Content Date	(0008,0023)	O	O	-	Single Value, Range, Universal
Content Time	(0008,0033)	O	O	-	Single Value, Range, Universal
Modality	(0008,0060)	O	O	-	Single Value, Wildcard, Universal
Image Comments	(0020,4000)	O	O	-	Universal

Attribute name	Tag	PR	SR	PSo	Matching
Referenced Request Sequence	(0040,A370)	O	O	-	Sequence matching
>Accession Number	((0008,0050)	O	O	-	Single value, Universal
>Requested Procedure ID	(0040,1000)	O	O	-	Single value, Universal
Concept Name Code Sequence	(0040,A043)	O	O	-	Sequence matching
>Code Value	(0008,0100)	O	O	-	Single Value, Wildcard, Universal
>Coding Scheme Designator	(0008,0102)	O	O	-	Single Value, Wildcard, Universal
>Coding Scheme Version	(0008,0103)	O	O	-	Single Value, Wildcard, Universal
>Code Meaning	(0008,0104)	O	O	-	Single Value, Wildcard, Universal
Template Identifier	(0040, DB00)	O	O	-	Single Value, Wildcard, Universal
Completion Flag	(0040, A491)	O	O	-	Single Value, Wildcard, Universal
Verification Flag	(0040, A493)	O	O	-	Single Value, Wildcard, Universal
Verifying Observer Sequence	(0040,A073)	O	O	-	Sequence matching
>Verifying Organization	(0040, A027)	O	O	-	Single Value, Wildcard, Universal
>Verifying Date Time	(0040, A030)	O	O	-	Single Value, Range, Universal
>Verifying Observer Name	(0040, A075)	O	O	-	Single Value, Wildcard, Universal
>Verifying Observer Identification Code Sequence	(0040, A088)	O	O	-	Sequence matching
>>Code Value	(0008,0100)	O	O	-	Single Value, Wildcard, Universal
>>Coding Scheme Designator	(0008,0102)	O	O	-	Single Value, Wildcard, Universal
>>Coding Scheme Version	(0008,0103)	O	O	-	Single Value, Wildcard, Universal

Attribute name	Tag	PR	SR	PSo	Matching
>>Code Meaning	(0008,0104)	O	O	-	Single Value, Wildcard, Universal

PR = Patient Root Information Model, SR = Study Root Information Model, PSo = Patient/Study Only Information Model

U = Unique Key, R = Required Key, O = Optional Key, - = not supported or applicable

The “Process Search Requests” activity can return the following status codes:

Table 21: Status Codes Process Search Request

Service Status	Meaning	Protocol Codes	Related Fields
Refused	Out of Resources	A700	(0000,0902)
Failed	Identifier does not match SOP Class	A900	(0000,0901) (0000,0902)
	Unable to process	C001	(0000,0901) (0000,0902)
Cancel	Matching terminated due to Cancel request	FE00	None
Success	Matching is complete - No final Identifier is supplied	0000	None
Pending	Matches are continuing - Current Match is supplied and any Optional Keys were supported in the same manner as Required Keys	FF00	Identifier
	Matches are continuing - Warning that one or more Optional Keys were not supported for existence and/or matching for this identifier	FF01	Identifier

4.2.1.4.5 Activity – “Receive Get Request”

4.2.1.4.5.1 Description and Sequencing of Activities

The associated Real-World activity is to respond to retrieve requests initiated from a foreign SCU. Relational retrieve operation is NOT supported.

Multiple C-GET requests over the same association are NOT supported.

4.2.1.4.5.2 Accepted Presentation Contexts

The Biograph Vision DICOM application will accept Presentation Contexts as shown in the following table:

Table 22: Acceptable Presentation Contexts for Storage AE and "Receive Get Request"

Abstract Syntax		Transfer Syntax		Role	Extended Negotiation
Name	UID	Name List	UID List		
Patient Root Query/Retrieve Information Model - GET	1.2.840.10008.5.1.4.1.2.1.3	Implicit VR Little Endian	1.2.840.10008.1.2	SCP	None
		Explicit VR Big Endian	1.2.840.10008.1.2.2		
		Explicit VR Little Endian	1.2.840.10008.1.2.1		
Study Root Query/Retrieve Information Model - GET	1.2.840.10008.5.1.4.1.2.2.3	Implicit VR Little Endian	1.2.840.10008.1.2	SCP	None
		Explicit VR Big Endian	1.2.840.10008.1.2.2		
		Explicit VR Little Endian	1.2.840.10008.1.2.1		
Patient/Study Only Query/Retrieve Information Model - GET	1.2.840.10008.5.1.4.1.2.3.3	Implicit VR Little Endian	1.2.840.10008.1.2	SCP	None
		Explicit VR Big Endian	1.2.840.10008.1.2.2		
		Explicit VR Little Endian	1.2.840.10008.1.2.1		

Note: C-GET Extended Negotiation will be NOT supported by the SCP.

Acceptance of Presentation Context is depending on the proposal of the SCU. As Transfer Syntax Selection Policy, for a supported Abstract Syntax the first supported Transfer Syntax supported is taken from list of proposals and accepted.

4.2.1.4.5.3 SOP specific Conformance for SOP Classes

Relational retrieve operation is not supported.

All unique keys must be supplied according to the selected Query/Retrieve Level. The related tables in the C-FIND SCP section will give information about "U" marked key attributes.

The C-STORE can only be performed to AEs that are configured in the Biograph Vision.

The "Receive Get Request" activity can return the following status codes:

Table 23: Status Codes "Receive Get Request"

Service Status	Meaning	Protocol Codes	Related Fields
Success	Sub-operations Complete - No Failures or Warning	0000	(0000,1020) (0000,1021) (0000,1022) (0000,1023)
Refused	Out of Resources - Unable to calculate number of matches	A701	(0000,0902)
	Out of Resources - Unable to perform suboperations	A702	(0000,1020) (0000,1021) (0000,1022) (0000,1023)

Service Status	Meaning	Protocol Codes	Related Fields
Failed	Identifier does not match SOP Class	A900	(0000,0901) (0000,0902)
	Unable to process	C001	(0000,0901) (0000,0902)
Cancel	Sub-operations terminated due to Cancel Indication	FE00	(0000,1020) (0000,1021) (0000,1022) (0000,1023)
Warning	Sub-operations Complete - One or more Failures of Warnings	B000	(0000,1020) (0000,1021) (0000,1022) (0000,1023)
Pending	Sub-operations are continuing	FF00	(0000,1020) (0000,1021) (0000,1022) (0000,1023)

4.2.1.4.6 Activity – “Receive Move Request”

4.2.1.4.6.1 Description and Sequencing of Activities

The associated Real-World activity is to respond to retrieve requests initiated from a foreign SCU. Relational retrieve operation is NOT supported.

Multiple C-MOVE requests over the same association are NOT supported.

4.2.1.4.6.2 Accepted Presentation Contexts

The Biograph Vision DICOM application will accept Presentation Contexts as shown in the following table:

Table 24: Acceptable Presentation Contexts for Storage AE and “Receive Move Request”

Abstract Syntax		Transfer Syntax		Role	Extended Negotiation
Name	UID	Name List	UID List		
Patient Root Query/Retrieve Information Model - MOVE	1.2.840.10008.5.1.4.1.2.1.2	Implicit VR Little Endian	1.2.840.10008.1.2	SCP	None
		Explicit VR Big Endian	1.2.840.10008.1.2.2		
		Explicit VR Little Endian	1.2.840.10008.1.2.1		
Study Root Query/Retrieve Information	1.2.840.10008.5.1.4.1.2.2.2	Implicit VR Little Endian	1.2.840.10008.1.2	SCP	None
		Explicit VR Big Endian	1.2.840.10008.1.2.2		
		Explicit VR Little Endian	1.2.840.10008.1.2.1		

Abstract Syntax		Transfer Syntax		Role	Extended Negotiation
Name	UID	Name List	UID List		
Model - MOVE					
Patient/Study Only Query/Retrieve Information Model - MOVE	1.2.840.10008.5.1.4.1.2.3.2	Implicit VR Little Endian	1.2.840.10008.1.2	SCP	None
		Explicit VR Big Endian	1.2.840.10008.1.2.2		
		Explicit VR Little Endian	1.2.840.10008.1.2.1		

Note: C-MOVE Extended Negotiation will be NOT supported by the SCP.

Acceptance of Presentation Context is depending on the proposal of the SCU. As Transfer Syntax Selection Policy, for a supported Abstract Syntax the first supported Transfer Syntax supported is taken from list of proposals and accepted.

4.2.1.4.6.3 SOP specific Conformance for SOP Classes

Relational retrieve operation is not supported.

All unique keys must be supplied according to the selected Query/Retrieve Level. The related tables in the C-FIND SCP section will give information about "U" marked key attributes.

The C-STORE can only be performed to AEs that are configured in the Biograph Vision.

The "Receive Move Request" activity can return the following status codes:

Table 25: Status Codes "Receive Move Request"

Service Status	Meaning	Protocol Codes	Related Fields
Success	Sub-operations Complete - No Failures or Warning	0000	(0000,1020) (0000,1021) (0000,1022) (0000,1023)
Refused	Out of Resources - Unable to calculate number of matches	A701	(0000,0902)
	Out of Resources - Unable to perform suboperations	A702	(0000,1020) (0000,1021) (0000,1022) (0000,1023)
Failed	Identifier does not match SOP Class	A900	(0000,0901) (0000,0902)
	Unable to process	C001	(0000,0901) (0000,0902)

Service Status	Meaning	Protocol Codes	Related Fields
Cancel	Sub-operations terminated due to Cancel Indication	FE00	(0000,1020) (0000,1021) (0000,1022) (0000,1023)
Warning	Sub-operations Complete - One or more Failures of Warnings	B000	(0000,1020) (0000,1021) (0000,1022) (0000,1023)
Pending	Sub-operations are continuing	FF00	(0000,1020) (0000,1021) (0000,1022) (0000,1023)

4.2.2 Print AE Specification

4.2.2.1 SOP Classes

For SOP Classes supported, please refer to “Table 1: Network Services” section “Print Management” in chapter 1 “Conformance Statement Overview”

4.2.2.2 Association Policy

4.2.2.2.1 General

Whenever a film is completely set up and printed by command or automatism, the job is prepared for processing. As soon as the queue is ready to process the job is activated and carried out according to the processing data. The related Print application will initiate an association to the print destination and process the printing of the related information.

The default PDU size from Biograph Vision will be 32 KB.

4.2.2.2.2 Number of Associations

The Biograph Vision DICOM Print application initiates one association at a time for print device configured.

4.2.2.2.3 Asynchronous Nature

The Biograph Vision DICOM implementation does not support asynchronous communication (multiple outstanding transactions over a single association).

4.2.2.2.4 Implementation Identifying Information

For Implementation Identifying Information please refer to “Table 3: Implementation Identifying Information” in the “Conformance Statement Overview”.

4.2.2.3 Association Initiation Policy

Triggered by the Print job queue the Print Management SCU establishes an association by using the DICOM association services. With the help of the N-GET request for the printer SOP Class the Status is determined before printing.

After the last film is printed from the queue, the Print application will leave open the association for another 60 seconds. If a new film job is ready for printing within this time limit, the job will be processed immediately over the association still open. If there is no new job, the association is closed.

During the "idle time" (no open association to printer) the Print application will issue a cyclic camera status request (using N-GET of Printer SOP Class) every 5 minutes.

4.2.2.3.1 Activity – “Send Verification Request”

4.2.2.3.1.1 Description and Sequencing of Activities

Triggered by the Biograph Vision Service UI, the Print AE attempts to initiate a new association for

- DIMSE C-ECHO

Service operation.

The Print AE serves as SCU of the Verification Service Class. A C-ECHO-RQ is initiated by the Service and Configuration SW environment whenever a "Verification" is requested. If an association to a remote Application Entity is successfully established, Verification with the configured AET is requested via the open association. If the C-ECHO Response from the remote Application contains a status other than "Success" this will be indicated in the service environment and the association is closed.

4.2.2.3.1.2 Proposed Presentation Contexts

The Storage AE will propose a Presentation Context as shown in the following table:

Table 26: Proposed Presentation Contexts for Print AE

Abstract Syntax		Transfer Syntax		Role	Extended Negotiation
Name	UID	Name List	UID List		
Verification	1.2.840.10008.1.1	Implicit VR Little Endian	1.2.840.10008.1.2	SCU	None
		Explicit VR Little Endian	1.2.840.10008.1.2.1		
		Explicit VR Big Endian	1.2.840.10008.1.2.2		

4.2.2.3.1.3 SOP specific Conformance for SOP Classes

The Print AE conforms to the definition of a Verification SCU in accordance with the DICOM Standard.

4.2.2.3.2 Activity – “Print Film”

4.2.2.3.2.1 Description and Sequencing of Activities

The film sheet is internally processed, converted to a STANDARD\1,1 page and then the page image is sent. Status is controlled by awaiting any N-EVENT message all through the transfer until the last image or film sheet is sent.

If the response from the remote application contains a status other than Success or Warning the association is aborted.

4.2.2.3.2.2 Proposed Presentation Contexts

The Biograph Vision DICOM application will propose Presentation Contexts as shown in the following table:

Table 27: Proposed Presentation Contexts for Print AE

Abstract Syntax		Transfer Syntax		Role	Extended Negotiation
Name	UID	Name List	UID List		
Basic Grayscale Print Management Meta SOP Class	1.2.840.10008.5.1.1.9	Implicit VR Little Endian Transfer Syntax	1.2.840.10008.1.2	SCU	None
		Explicit VR Little Endian Transfer Syntax	1.2.840.10008.1.2.1		
		Explicit VR Big Endian Transfer Syntax	1.2.840.10008.1.2.2		
Basic Color Print Management Meta SOP Class	1.2.840.10008.5.1.1.18	Implicit VR Little Endian Transfer Syntax	1.2.840.10008.1.2	SCU	None
		Explicit VR Little Endian Transfer Syntax	1.2.840.10008.1.2.1		
		Explicit VR Big Endian Transfer Syntax	1.2.840.10008.1.2.2		
Basic film session SOP Class	1.2.840.10008.5.1.1.1	Implicit VR Little Endian Transfer Syntax	1.2.840.10008.1.2	SCU	None
		Explicit VR Little Endian Transfer Syntax	1.2.840.10008.1.2.1		
		Explicit VR Big Endian Transfer Syntax	1.2.840.10008.1.2.2		
Basic film box SOP Class	1.2.840.10008.5.1.1.2	Implicit VR Little Endian Transfer Syntax	1.2.840.10008.1.2	SCU	None
		Explicit VR Little Endian Transfer Syntax	1.2.840.10008.1.2.1		
		Explicit VR Big Endian Transfer Syntax	1.2.840.10008.1.2.2		
Basic grayscale image box SOP Class	1.2.840.10008.5.1.1.4	Implicit VR Little Endian Transfer Syntax	1.2.840.10008.1.2	SCU	None
		Explicit VR Little Endian Transfer Syntax	1.2.840.10008.1.2.1		
		Explicit VR Big Endian Transfer Syntax	1.2.840.10008.1.2.2		
Basic color image box SOP Class	1.2.840.10008.5.1.1.4.1	Implicit VR Little Endian Transfer Syntax	1.2.840.10008.1.2	SCU	None
		Explicit VR Little Endian Transfer Syntax	1.2.840.10008.1.2.1		
		Explicit VR Big Endian Transfer Syntax	1.2.840.10008.1.2.2		
Printer SOP Class	1.2.840.10008.5.1.1.16	Implicit VR Little Endian Transfer Syntax	1.2.840.10008.1.2	SCU	None
		Explicit VR Little Endian Transfer Syntax	1.2.840.10008.1.2.1		
		Explicit VR Big Endian Transfer Syntax	1.2.840.10008.1.2.2		
Print Job SOP Class	1.2.840.10008.5.1.1.14	Implicit VR Little Endian Transfer Syntax	1.2.840.10008.1.2	SCU	None
		Explicit VR Little Endian Transfer Syntax	1.2.840.10008.1.2.1		

Abstract Syntax		Transfer Syntax		Role	Extended Negotiation
Name	UID	Name List	UID List		
		Explicit VR Big Endian Transfer Syntax	1.2.840.10008.1.2.2		
Presentation LUT SOP Class	1.2.840.10008.5.1.1.2.3	Implicit VR Little Endian Transfer Syntax	1.2.840.10008.1.2	SCU	None
		Explicit VR Little Endian Transfer Syntax	1.2.840.10008.1.2.1		
		Explicit VR Big Endian Transfer Syntax	1.2.840.10008.1.2.2		

4.2.2.3.2.3 SOP specific Conformance for SOP Classes

4.2.2.3.2.3.1 Meta SOP Classes

The Biograph Vision DICOM Print Management SCU conforms to the DICOM Basic Grayscale Print Management Meta SOP Class and Basic Color Print Management Meta SOP Class.

The application uses a setting platform to define the properties of the connected DICOM SCP, e.g.:

- maximum number of print jobs in the queue
- maximum number of print copies
- supported film sizes of the connected DICOM SCP
- supported film formats of the DICOM SCP
- lookup table definition.

The printing is only suspended in the case of a failure return status of the SCP.

4.2.2.3.2.3.2 Basic Film Session SOP Class

The Basic Film Session information object definition describes all the user defined parameter which are common for all the films of a film session. The Basic Film Session refers to one or more Basic Film Boxes and that are printed on one hardcopy printer.

The Biograph Vision DICOM Print application supports the following DIMSE Service Elements for the Basic Film Session SOP Class as SCU:

- N-CREATE
- N-DELETE

The Basic Film Session SOP Class N-CREATE-RQ (SCU) uses following attributes:

Table 28: Used Basic Film Session N-CREATE-RQ attributes

Attribute name	Tag	Usage SCU	Supported Values
Number of Copies	(2000,0010)	U	1
Medium Type	(2000,0030)	U	BLUE FILM CLEAR FILM PAPER
Film Destination	(2000,0040)	U	MAGAZINE PROCESSOR

The number of copies sent to the DICOM printer is always 1, the job is sent n times for n copies.

The Affected SOP Instance UID received with N-CREATE-RSP message from SCP will be kept internally and used for later requests (e.g., N-DELETE-RQ) on the Basic Film Session SOP Class - see table below:

Table 29: Attributes of the N-DELETE-RQ on the Basic Film Session SOP Class

Attribute name	Tag	Source of information
Requested SOP Instance UID	(0000,1000) -> (0000,1001)	Affected SOP Instance UID of N-CREATE-RSP on Basic Film Session

The N-DELETE-RQ on the Basic Film Session SOP Class is used to delete the complete Basic Film Session SOP Instance hierarchy.

The Basic Film Session SOP Class interprets the following status codes (from N-CREATE-RSP, N-DELETE-RSP messages):

Table 30: Basic Film Session SOP status

Service Status	Meaning	Protocol Codes
Failure	Film session SOP instances hierarchy does not contain film box SOP instances	C600
	Unable to create print job, print queue is full	C601
	Image size is larger than images box size	C603
Warning	Memory allocation not supported	B600
	Film session printing is not supported	B601
	Film box does not contain image box (empty page)	B602
Success	Film belonging to the film session are accepted for printing	0000

4.2.2.3.2.3.3 *Basic Film Box SOP Class*

The Basic Film Box information object definition describes all the user defined parameter of one film of the film session. The Basic Film Box information description defines the presentation parameters which are common for all images on a given sheet of film.

The Basic Film Box refers to one or more Image Boxes.

Supported as SCU are:

- N-CREATE
- N-ACTION
- N-DELETE

The Basic Film Box SOP Class N-CREATE-RQ message uses following attributes (the used values for each attribute depend on the DICOM Printer configuration within the Biograph Vision DICOM print management SCU):

Table 31: Used Film Box N-CREATE-RQ attributes

Attribute name	Tag	Usage SCU	Supported Values
Image Display Format	(2010,0010)	M	STANDARD\1,1
Referenced Film Session Sequence	(2010,0500)	M	
>Referenced SOP Class UID	(0008,1150)	M	1.2.840.10008.5.1.1.1.1
>Referenced SOP Instance UID	(0008,1155)	M	
Film Orientation	(2010,0040)	M	PORTRAIT LANDSCAPE
Film Size ID	(2010,0050)	M	8INX10IN 10INX12IN 10INX14IN 11INX14IN 14INX14IN 14INX17IN 24CMX24CM 24CMX30CM
Magnification Type	(2010,0060)	M	BILINEAR CUBIC NONE REPLICATE
Border Density	(2010,0100)	U	BLACK WHITE
Max Density	(2010,0130)	U	0 < Value
Min Density	(2010,0120)	U	0 < Value < 50
Illumination	(2010,015E)	U	0 < Value Required if Presentation LUT is present
Reflective Ambient Light	(2010,0160)	U	0 < Value Required if Presentation LUT is present
Referenced Presentation LUT Sequence	(2050,0500)	U	

M = Mandatory, **U** = User Option

The N-CREATE-RSP message from the Print SCP includes the Referenced Image Box Sequence with its SOP Class / Instance UID pairs which will be kept internally to be further used for the subsequent Basic Image Box SOP Class N-SET-RQ messages.

When all Image Boxes (including parameters) for the film sheet have been set, the Biograph Vision DICOM print manager will issue a N-ACTION-RQ message with the SOP Instance UID of the Basic Film Box (returned in N-CREATE-RSP of Basic Film Box SOP Class) and the Action Type ID of 1.

The affected SOP Instance UID received with N-CREATE-RSP message will be kept internally and used for later requests (e.g. N-DELETE-RQ) on the Basic Film Box SOP Class - see table below:

Table 32: Attributes of the N_DELETE-RQ on the Basic Film Session SOP Class

Attribute name	Tag	Source of information
Requested SOP Instance UID	(0000,1000) -> (0000,1001)	Affected SOP Instance UID of N-CREATE-RSP on Basic Film Box

The Basic Film Box SOP Class interprets the following status codes:

Table 33: Basic Film Box SOP status

Service Status	Meaning	Protocol Codes
Failure	Unable to create print job; print queue is full	C602
	Image size is larger than image box size	C603
Warning	Film box does not contain image box (empty page)	B603
	Requested MinDensity or MaxDensity outside of printer's operating range	B605
Success	Film accepted for printing	0000

4.2.3.2.3.4 *Basic Grayscale Image Box SOP Class*

The Basic Grayscale Image Box information object definition is the presentation of an image and image related data in the image area of a film. The Basic Image Box information describes the presentation parameters and image pixel data which apply to a single image of a sheet of film.

The Grayscale Image Box SOP Class uses only the N-SET-RQ with the following attributes

Table 34: Used Basic Grayscale Image Box N-SET attributes

Attribute name	Tag	Usage SCU	Supported Values
Image Position	(2020,0010)	M	1
Basic Grayscale Image Sequence	(2020,0110)	M	
>Samples per Pixel	(0028,0002)	M	1
>Photometric Interpretation	(0028,0004)	M	MONOCH-ROME2
>Rows	(0028,0010)	M	<Printer/Film config>
>Columns	(0028,0011)	M	<Printer/Film config>
>Pixel Aspect Ratio	(0028,0034)	M	(1:1)
>Bits Allocated	(0028,0100)	M	8,16
>Bits Stored	(0028,0101)	M	8,12

Attribute name	Tag	Usage SCU	Supported Values
>High Bit	(0028,0102)	M	7,11
>Pixel Representation	(0028,0103)	M	0
>Pixel Data	(7FE0,0010)	M	

M = Mandatory

The Grayscale Image Box SOP Class interprets following status codes:

Table 35: Basic Grayscale Image Box SOP status

Service Status	Meaning	Protocol Codes
Failure	Image contains more pixel than printer can print in Image box	C603
	Insufficient memory in printer to store the image	C605
Warning	Requested MinDensity or MaxDensity outside of printer’s operating range	B605
Success		0000

4.2.2.3.2.3.5 *Basic Color Image Box SOP Class*

The Basic Color Image Box information object definition is the presentation of an image and image related data in the image area of a film. The Basic Image Box information describes the presentation parameters and image pixel data which apply to a single image of a sheet of film.

The Color Image Box SOP Class uses only the N-SET-RQ with the following attributes

Table 36: Used Basic Color Image Box N-SET attributes

Attribute name	Tag	Usage SCU	Supported Values
Image Position	(2020,0010)	M	1
Basic Color Image Sequence	(2020,0111)	M	
>Samples per Pixel	(0028,0002)	M	3
>Photometric Interpretation	(0028,0004)	M	RGB
>Planar Configuration	(0028,0006)	M	0
>Rows	(0028,0010)	M	
>Columns	(0028,0011)	M	
>Pixel Aspect Ratio	(0028,0034)	M	
>Bits Allocated	(0028,0100)	M	8

Attribute name	Tag	Usage SCU	Supported Values
>Bits Stored	(0028,0101)	M	8
>High Bit	(0028,0102)	M	7
>Pixel Representation	(0028,0103)	M	0
>Pixel Data	(7FE0,0010)	M	

The Color Image Box SOP Class interprets following status codes:

Table 37: Basic Color Image Box SOP status

Service Status	Meaning	Protocol Codes
Failure	Image contains more pixel than printer can print in Image box	C603
	Insufficient memory in printer to store the image	C605
Warning	Image size larger than image box size.	B604
Success		0000

4.2.3.3.2.3.6 *Presentation LUT SOP Class*

The objective of the Presentation LUT is to realize image hardcopy printing tailored for specific modalities, applications, and user preferences.

The output of the Presentation LUT is Presentation Values (P-Values). P-Values are approximately related to human perceptual response. They are intended to facilitate common input for hardcopy. P-Values are intended to be independent of the specific class or characteristics of the hardcopy device.

Table 38: Attributes of the N_CREATE-RQ on the Presentation LUT SOP Class

Attribute name	Tag	Usage SCU	Supported Values
Presentation LUT Shape	(2050,0020)	U	IDENTITY

The affected SOP Instance UID received with N-CREATE-RSP message will be kept internally and is used for later requests on the Basic Film Box (N-CREATE-RQ) and on the Presentation LUT (N-DELETE-RQ) - see below.

Table 39: Attributes of the N_DELETE-RQ on the Presentation LUT SOP Class

Attribute name	Tag	Source of information
Requested SOP Instance UID	(0000,1000) -> (0000,1001)	Affected SOP Instance UID of N-CREATE-RSP on Presentation LUT

The Presentation LUT SOP Class interprets the following status codes:

Table 40: Attributes of the N_DELETE-RQ on the Presentation LUT SOP Class

Service Status	Meaning	Protocol Codes
Warning	Requested Min Density or Max Density outside the HCD's operating range. HCD will use its respective minimum or maximum density value instead.	B605
Success	Presentation LUT successfully created	0000

4.2.2.3.2.3.7 *Printer SOP Class*

The Printer SOP Class is the possibility to monitor the status of the hardcopy printer in a synchronous and an asynchronous way.

The SCU uses the mandatory N-EVENT-REPORT DIMSE service to monitor the changes of the printer status in an asynchronous way.

In both cases the following information is supported:

Table 41: Used Printer N-EVENT-REPORT

Event type name	Event	Attributes	Tag	Usage SCU
Normal	1			
Warning	2	Printer Status Info	(2110,0020)	U
Failure	3	Printer Status Info	(2110,0020)	U

U = User Option

Table 42: Mandatory Printer N-GET-RSP, N-EVENT-REPORT-RQ attributes

Attribute name	Tag	Usage SCP	Supported Values
Printer Status	(2110,0010)	M	NORMAL FAILURE WARNING
Printer Status Info	(2110,0020)	M	See tables in Annex for details.

M = Mandatory

Note: For a detailed description on how syngo reacts on different printer status messages, please refer to the Annex section.

4.2.2.3.2.3.8 *Print Job SOP Class*

The Print Job SOP Class is the possibility to monitor the execution of the print process.

The Biograph Vision DICOM Print application supports the optional N-EVENT-REPORT DIMSE service to receive the changes of the print job status in an asynchronous way.

It can receive events from the Print SCP asynchronously:

- N-EVENT-REPORT

Note: The underlying Biograph Vision DICOM Print AE does not support receiving of N-EVENT-REPORT messages from camera during open print sessions. This is typically configurable in the camera setup.

The following information is supported:

Table 43: Used Print Job N-EVENT-REPORT attributes

Event type name	Event	Attributes	Tag	Usage SCU
Normal	1	Execution Status Info	(2100,0030)	U
		Print Job ID	(2100,0010)	- (Print Queue Management SOP Class not supported)
		Film Session Label	(2000,0050)	U
		Printer Name	(2110,0030)	U
Printing	2	Execution Status Info	(2100,0030)	U
		Print Job ID	(2100,0010)	- (Print Queue Management SOP Class not supported)
		Film Session Label	(2000,0050)	U
		Printer Name	(2110,0030)	U
Done	3	Execution Status Info	(2100,0030)	U
		Print Job ID	(2100,0010)	- (Print Queue Management SOP Class not supported)
		Film Session Label	(2000,0050)	U
		Printer Name	(2110,0030)	U
Failure	4	Execution Status Info	(2100,0030)	U
		Print Job ID	(2100,0010)	- (Print Queue Management SOP Class not supported)
		Film Session Label	(2000,0050)	U
		Printer Name	(2110,0030)	U

U = User Option

Note: For a detailed description on how Biograph Vision reacts on different printer status messages, please refer to the Annex section.

4.2.2.3.3 Activity – “Get Printer Status Information”

4.2.2.3.3.1 Description and Sequencing of Activities

With no printing activity ongoing (“idle time”), the Biograph Vision DICOM Print SCU application will cyclically request the printer status to update the related printer state in the Printing UI.

4.2.2.3.3.2 Proposed Presentation Context

The Biograph Vision DICOM application will propose Presentation Contexts as shown in the following table:

Table 44: Proposed Presentation Contexts for Print AE

Presentation Context Table					
Abstract Syntax		Transfer Syntax		Role	Extended Negotiation
Name	UID	Name List	UID List		
Printer SOP Class	1.2.840.10008.5.1.1.16	Implicit VR Little Endian	1.2.840.10008.1.2	SCU	None
		Explicit VR Little Endian	1.2.840.10008.1.2.1		
		Explicit VR Big Endian	1.2.840.10008.1.2.2		

4.2.2.3.3.3 SOP Specific Conformance

The Printer SOP Class allows to monitor the status of the hardcopy printer in a synchronous and an asynchronous way.

The Print SCU AE application will cyclically “ask” the Printer (SCP) for its status synchronously:

N-GET as SCU

The following information is supported:

Table 45: Used Printer N-EVENT-REPORT attributes

Event-type Name	Event	Attributes	Tag	Usage SCU
Normal	1			
Warning	2	Printer Status Info	(2110,0020)	U
Failure	3	Printer Status Info	(2110,0020)	U

U = User Option

4.2.2.4 Association Acceptance Policy

N/A

4.2.3 Workflow AE Specification

The Modality Worklist SCU (patient registration in conjunction with the network application) requests that the remote SCP performs a match of all keys specified in the query against the information in its worklist database.

4.2.3.1 SOP Classes

The Biograph Vision Workflow AE provides Standard Conformance to the Verification SOP Class, the Modality Worklist Information Model – FIND SOP Class and to the Modality Performed Procedure Step SOP Class, as listed in “Table 1: Network Services” section “Workflow Management” of the Conformance Statement Overview.

4.2.3.2 Association Policy

4.2.3.2.1 General

The Workflow AE attempts to open an association for verification request whenever the "verification" function is activated during network configuration of a remote DICOM application.

For Modality Worklist, it is possible to configure a cyclic update of the modality scheduler database through a background worklist request with date/time and modality information.

In addition, the user can request worklist update with "Update Worklist". No duplicate entries will be added in the Scheduler DB. Entries are uniquely identified by the Study Instance UID (0020,000D) for the Requested Procedure and the SPS ID (0040,0009) in the SPS Sequence (0040,0100).

An interactive worklist query can be issued with search criteria entered in the patient-based Query dialog from the patient browser.

The default PDU size used will be 32 KB.

For Modality Performed Procedure Step, the creation of a MPPS Instance is done automatically by the Biograph Vision Workflow AE whenever a patient is registered for image acquisition through the Patient Registration dialog. Exception: In case of Emergency Patients the MPPS is created only when the user explicitly sends a corresponding message from the MPPS user interface.

Further updates on the MPPS data can be done interactively from the related MPPS user interface. The MPPS "Complete" or "Discontinued" states can be set manually from user interface or configured to be set automatically after examination is ended.

The default PDU size used will be 32 KB.

4.2.3.2.2 Number of Associations

The Biograph Vision Workflow AE initiates one association at a time to query worklist entry data.

The Biograph Vision Workflow AE initiates one association at a time to create or set MPPS instance.

4.2.3.2.3 Asynchronous Nature

The Biograph Vision Workflow AE does not support asynchronous communication (multiple outstanding transactions over a single association).

4.2.3.2.4 Implementation Identifying Information

The Biograph Vision software is using common Implementation Identifying Information for all network related AEs.

For detailed Application Context Name, Implementation Class UID and Implementation Version Name please refer to common Table 3: Implementation Identifying Information in the "Conformance Statement Overview".

4.2.3.3 Association Initiation Policy

The Workflow AE will cyclically query the worklist provider and by request from the patient registration interface. It establishes an association by using the

- C-FIND with Worklist information model

It is possible to configure multiple worklist providers but only one can be active at a time. The active worklist provider can be selected in the user settings.

The Workflow AE acts as a Service Class User (SCU) for the Modality Performed Procedure Step Service Class (to notify a RIS about status of a procedure while it is performed).

To do so, it will issue a:

- N-CREATE DIMSE according to the CREATE Modality Performed Procedure Step SOP Instance operation or a
- N-SET DIMSE to update the contents and state of the MPPS according to the SET Modality Performed Procedure Step Information operation.

It is possible to configure multiple MPPS providers but only one can be active at a time. The active MPPS provider can be selected in the user settings.

4.2.3.3.1 Activity – “Send Verification Request”

4.2.3.3.1.1 Description and Sequencing of Activities

Triggered by the Biograph Vision Service UI, the Workflow AE attempts to initiate a new association for

- DIMSE C-ECHO

Service operation.

The Workflow AE serves as SCU of the Verification Service Class. A C-ECHO-RQ is initiated by the Service and Configuration SW environment whenever a "Verification" is requested. If an association to a remote Application Entity is successfully established, Verification with the configured AET is requested via the open association. If the C-ECHO Response from the remote Application contains a status other than "Success" this will be indicated in the service environment and the association is closed.

4.2.3.3.1.2 Proposed Presentation Contexts

The Workflow AE will propose a Presentation Context as shown in the following table:

Table 46: Proposed Presentation Contexts for Workflow AE

Abstract Syntax		Transfer Syntax		Role	Extended Negotiation
Name	UID	Name List	UID List		
Verification	1.2.840.10008.1.1	Implicit VR Little Endian	1.2.840.10008.1.2	SCU	None
		Explicit VR Little Endian	1.2.840.10008.1.2.1		
		Explicit VR Big Endian	1.2.840.10008.1.2.2		

4.2.3.3.1.3 SOP specific Conformance for SOP Classes

The Workflow AE conforms to the definition of a Verification SCU in accordance with the DICOM Standard.

4.2.3.3.2 Activity – “Send Modality Worklist Query Request”

4.2.3.3.2.1 Description and Sequencing of Activities

A network application will perform worklist queries with the C-FIND request at regular intervals. In addition, it can be triggered by immediate request. The received worklist items will be compared with the contents of the local scheduler database. New items will be inserted into scheduler database.

After each broad query all RP/SPS that were cancelled or rescheduled to another modality at the RIS will be automatically removed from the scheduler DB if:

1. the Examination of this procedure has not been started or finished yet

2. the corresponding configuration item "Automatic removal of cancelled/rescheduled Request" was checked in the Service UI under DICOM / HIS/RIS Node

With "Get Worklist" in the patient-based Worklist Query dialog the entered attributes are used to form a worklist request identifier. With the response data the Patient Registration dialog can be updated to perform examination in advance. The response data are additionally placed in the scheduler database.

No automatic clean-up of the scheduler DB is performed after a Patient based Query since the worklist received does not give the complete list of all currently scheduled procedures for the modality.

4.2.3.3.2.2 Proposed Presentation Contexts

The Biograph Vision Workflow AE will propose Presentation Contexts as shown in the following table:

Table 47: Proposed Presentation Contexts for Workflow AE

Presentation Context Table – "Update Flag Information"				
Abstract Syntax	Transfer Syntax		Role	Extended Negotiation
Description	Name List	UID List		
1.2.840.10008.5.1.4.31 Modality Worklist Information Model - FIND	Explicit VR Little Endian	1.2.840.10008.1.2.1	SCU	None
	Explicit VR Big Endian	1.2.840.10008.1.2.2		
	Implicit VR Little Endian	1.2.840.10008.1.2		

4.2.3.3.2.3 SOP specific Conformance for SOP Classes

4.2.3.3.2.3.1 Search Key Attributes of the Worklist C-FIND (broad worklist queries)

The Biograph Vision DICOM Workflow AE supports "broad worklist queries" with all required search keys.

The following tables describe the "broad query" search keys that the SCU supports, which is a query for all tasks scheduled for the own modality or own modality application entity defined with the following search keys¹:

Table 48: Supported Broad Worklist Query Search Key Attributes

Attribute Name	Tag	Matching Key Type	Query Value
Scheduled Procedure Step			
Scheduled Procedure Step Sequence	(0040,0100)	R	
>Scheduled Station AE Title (It depends on user configuration (Options->Configuration-> Patient Registration) if the "own AET" is provided or not. Use the "HIS/RIS" tab card for configuration.)	(0040,0001)	R	<own AET> or <zero length>
>Schedule Procedure Step Start Date (It depends on user configuration (Options->Configuration-> Patient Registration) if the actual Date with a full-time range or an interactive input dialog for date/time specification is used.)	(0040,0002)	R	<act. Date>-<act. Date> or range from UI
>Schedule Procedure Step Start Time (It depends on user configuration (Options-	(0040,0003)	R	00.00-235959.00 or range from UI

¹ The worklist query will also contain additional(empty) optional DICOM defined attributes as valid for C-FIND-RQ. As a special extension in this version the query will send (0010,1002) Other Patient IDs Sequence. For return keys expected in C-FIND-RSP see 4.2.3.3.2.3.3

Attribute Name	Tag	Matching Key Type	Query Value
>Configuration-> Patient Registration) if the actual Date with a full-time range or an interactive input dialog for date/time specification is used.)			
>Modality (It depends on user configuration (Options->Configuration-> Patient Registration) if the "own Modality" is provided or not. Use the "HIS/RIS" tab card for configuration.)	(0008,0060)	R	<zero length> or <own Modality>

R = Required

4.2.3.3.2.3.2 Search Key Attributes of the Worklist C-FIND (narrow worklist queries)

The Biograph Vision DICOM Workflow AE supports “narrow worklist queries” with all required search keys. The following tables describe the “narrow query” search keys that the SCU supports.

Table 49: Search Key Attributes in a patient-based worklist query

Attribute name	Tag	Matching Key Type	query value
Scheduled Procedure Step			
Scheduled Procedure Step Sequence	(0040,0100)	R	
>Scheduled Performing Physician’s Name	(0040,0006)	R	inserted in UI or zero length
Requested Procedure			
Requested Procedure ID	(0040,1001)	O	inserted in UI or zero length
Imaging Service Request			
Accession Number	(0008,0050)	O	inserted in UI or zero length
Referring Physician’s Name	(0008,0090)	O	inserted in UI or zero length
Visit Status			
Current Patient Location	(0038,0300)	O	inserted in UI or zero length
Patient Identification			
Patient’s Name ¹	(0010,0010)	R	inserted in UI or zero length

¹ Please be aware that although in the UI there are different entries for First Name and Last Name of a patient these are combined into one query attribute. Querying just for the Last Name (without wildcard) or not providing a first letter for the First Name may prevent expected matches.

Attribute name	Tag	Matching Key Type	query value
Patient ID	(0010,0020)	R	inserted in UI or zero length

R = Required Key, O = Optional Key

For return keys expected in C-FIND-RSP see 4.2.3.3.2.3.3.

4.2.3.3.2.3.3 Return Key Attributes of the Worklist C-FIND-RSP

The Biograph Vision DICOM Workflow AE supports worklist queries with return key attributes of all types. The following tables describe the return keys that the SCU supports.

An "x" in the UI column will indicate that the attribute is visualized when browsing the Worklist results with Patient Browser and/or during Patient Registration. The Patient Browser display is additionally influenced by the related Browser configuration.

A tag in the IOD column will indicate that the related attribute is included into the SOP Instances of the IODs created during processing of this worklist request.

A tag in the MPPS column will indicate that the related attribute is included into the SOP Instances of the MPPS objects created during processing of this worklist request. (See also Table 53 and Table 55).

Table 50: Basic Worklist C-FIND-RSP Return Key Attributes

Attribute name	Tag	Return Key Type	UI	IOD	MPPS
SOP Common					
Specific Character Set ¹	(0008,0005)	1C	-	(0008,0005)	(0008,0005)
Scheduled Procedure Step					
Scheduled Procedure Step Sequence	(0040,0100)	1			
>Modality	(0008,0060)	1	x	(0008,0060)	(0008,0060)
>Requested Contrast Agent	(0032,1070)	2C	x	(0032,1070)	
>Scheduled Station AE Title (<i>"Scheduled Station AE Title" is taken as default for "Performed Station AE Title"</i>)	(0040,0001)	1	x		(0040,0241)
>Scheduled Procedure Step Start Date	(0040,0002)	1	x		
>Scheduled Procedure Step Start Time	(0040,0003)	1	x		
>Scheduled Procedure Step End Date	(0040,0004)	3	-		
>Scheduled Procedure Step End Time	(0040,0005)	3	-		
>Scheduled Performing Physician's Name (<i>"Scheduled Performing Physician's Name" is taken as default for "Performing Physician's Name"</i>)	(0040,0006)	1	x	(0008,1050)	(0008,1050)

¹ The Specific Character Set distributed via Modality Worklist by the hospital network shall reflect the global hospital context, e.g. a hospital with German context shall not restrict the worklist entries to ISO_IR 6 but supply a character set adequate to hold all German language text input.

Attribute name	Tag	Return Key Type	UI	IOD	MPPS
>Scheduled Procedure Step Description (<i>"Scheduled Procedure Step Description" is taken as default for "Performed Procedure Step Description"</i>)	(0040,0007)	1C	x	(0040,0007) (0040,0254)	(0040,0007) (0040,0254)
>Scheduled Protocol Code Sequence (<i>Uses Universal sequence Match</i>) (<i>"Scheduled Protocol Code Sequence" is taken as default for "Performed Pro-tocol Code Sequence"</i>)	(0040,0008)	1C	-	(0040,0008) (0040,0260)	(0040,0008) (0040,0260)
>>Code Value	(0008,0100)	1C	x		
>>Coding Scheme Designator	(0008,0102)	1C	x		
>>Coding Scheme Version	(0008,0103)	3	x		
>>Code Meaning	(0008,0104)	3	x		
>Scheduled Procedure Step ID (<i>"Scheduled Procedure Step ID" is taken as default for "Performed Procedure Step ID"</i>)	(0040,0009)	1	x	(0040,0009) (0040,0253)	(0040,0009) (0040,0253)
>Scheduled Station Name	(0040,0010)	2	x		
>Scheduled Procedure Step Location (<i>"Scheduled Procedure Step Location" is taken as default for "Performed Location"</i>)	(0040,0011)	2	x		(0040,0242) ¹
>Pre-Medication	(0040,0012)	2C	x		
>Scheduled Procedure Step Status	(0040,0020)	3	x		
>Comments on the Scheduled Procedure Step	(0040,0400)	3	-		
Requested Procedure					
Referenced Study Sequence (<i>Uses Universal sequence Match</i>)	(0008,1110)	2	-	(0008,1110)	(0008,1110)
>Referenced SOP Class UID	(0008,1150)	1C	-		
>Referenced SOP Instance UID	(0008,1155)	1C	-		
Study Instance UID	(0020,000D)	1	-	(0020,000D)	(0020,000D)
Requested Procedure Description	(0032,1060)	1C	x	(0032,1060)	(0032,1060)
Requested Procedure Code Sequence (<i>Uses Universal sequence Match</i>) (<i>"Requested Procedure Code Sequence" is taken as default for "Procedure Code Sequence"</i>)	(0032,1064)	1C	-	(0032,1032) (0032,1064)	(0032,1032)
>Code Value	(0008,0100)	1C	x		

¹ "Scheduled Procedure Step Location" is taken as default for "Performed Procedure Step Location"

Attribute name	Tag	Return Key Type	UI	IOD	MPPS
>Code Scheme Designator	(0008,0102)	1C	x		
>Code Scheme Version	(0008,0103)	3	x		
>Code Meaning	(0008,0104)	3	x		
Requested Procedure ID ("Requested Procedure ID" is taken as default for "Study ID")	(0040,1001)	1	x	(0040,1001) (0020,0010)	(0040,1001) (0020,0010)
Reason for the Requested Procedure	(0040,1002)	3	-		
Requested Procedure Priority	(0040,1003)	2	x		
Patient Transport Arrangements	(0040,1004)	2	-		
Requested Procedure Location	(0040,1005)	3	-		
Confidentiality Code	(0040,1008)	3	-		
Reporting Priority	(0040,1009)	3	-		
Names of Intended Recipients of results	(0040,1010)	3	-	(0008,1048)	
Requested Procedure Comments	(0040,1400)	3	x		
Imaging Service Request					
Accession Number	(0008,0050)	2	x	(0008,0050)	(0008,0050)
Referring Physician's Name	(0008,0090)	2	x	(0008,0090)	
Requesting Physician	(0032,1032)	2	x	(0032,1032)	(0032,1032)
Requesting Service	(0032,1033)	3	x	(0032,1033)	
Reason for the Imaging Service Request	(0040,2001)	3	-		
Issuing Date of Imaging Service Request	(0040,2004)	3	-		
Issuing Time of Imaging Service Request	(0040,2005)	3	-		
Placer Order Number / Imaging Service Request (Old tag (0040,2006) is retired and not used)	(0040,2016)	3	-		(0040,2016)
Filler Order Number / Imaging Service Request (Old tag (0040,2007) is retired and not used)	(0040,2017)	3	-		(0040,2017)
Order entered by...	(0040,2008)	3	-		
Order Enterer's Location	(0040,2009)	3	-		
Order Callback Phone Number	(0040,2010)	3	-		
Imaging Service Request Comments	(0040,2400)	3	x		
Visit Identification					
Institution Name	(0008,0080)	3	x	(0008,0080)	
Institution Address	(0008,0081)	3	-	(0008,0081)	
Institution Code Sequence (Uses universal sequence match)	(0008,0082)	3	-		

Attribute name	Tag	Return Key Type	UI	IOD	MPPS
>Code Value	(0008,0100)	1C			
>Code Scheme Designator	(0008,0102)	1C			
>Code Scheme Version	(0008,0103)	3			
>Code Meaning	(0008,0104)	3			
Admission ID	(0038,0010)	2	x		
Issuer of Admission ID	(0038,0011)	3	-		
Visit Status					
Visit Status ID	(0038,0008)	3	-		
Current Patient Location	(0038,0300)	2	x		
Patient's Institution Residence	(0038,0400)	3	-		
Visit Comments	(0038,4000)	3	-		
Visit Relationship					
Referenced Study Sequence <i>(Uses universal sequence match)</i>	(0008,1110)	3	-		
>Referenced SOP Class UID	(0008,1150)	1C	-		
>Referenced SOP Instance UID	(0008,1155)	1C	-		
Referenced Patient Sequence <i>(Uses universal sequence match)</i>	(0008,1120)	2	-		(0008,1120)
>Referenced SOP Class UID	(0008,1150)	1C	-		
>Referenced SOP Instance UID	(0008,1155)	1C	-		
Visit Admission					
Referring Physician's Name	(0008,0090)	2	x	(0008,0090)	
Referring Physician's Address	(0008,0092)	3	-		
Referring Physician's Phone Numbers	(0008,0094)	3	-		
Admitting Diagnoses Description	(0008,1080)	3	x	(0008,1080)	
Admitting Diagnosis Code Sequence	(0008,1084)	3			
>Code Value	(0008,0100)	1C			
>Code Scheme Designator	(0008,0102)	1C			
>Code Scheme Version	(0008,0103)	3			
>Code Meaning	(0008,0104)	3			
Route of Admissions	(0038,0016)	3	-		
Admitting Date	(0038,0020)	3	-		
Admitting Time	(0038,0021)	3	-		

Attribute name	Tag	Return Key Type	UI	IOD	MPPS
Patient Identification					
Patient's Name	(0010,0010)	1	x	(0010,0010)	(0010,0010)
Patient ID	(0010,0020)	1	x	(0010,0020)	(0010,0020)
Issuer of Patient ID	(0010,0021)	3	-	(0010,0021)	
Other Patient IDs	(0010,1000)	3	x	(0010,1000)	
Other Patient Names	(0010,1001)	3	x	(0010,1001)	
Other Patient IDs Sequence	(0010,1002)	3	x	(0010,1002)	
>Patient ID	(0010,0020)	3	X	(0010,0020)	
>Issuer of Patient ID	(0010,0021)	3	X	(0010,0021)	
>Type of Patient ID	(0010,0022)	3	X	(0010,0022)	
Patient's Birth Name	(0010,1005)	3	-	(0010,1005)	
Patient's Mother's Birth Name	(0010,1060)	3	-	(0010,1060)	
Medical Record Locator	(0010,1090)	3	-	(0010,1090)	
Patient Demographic					
Patients Birth Date	(0010,0030)	2	x	(0010,0030)	(0010,0030)
Patients Birth Time	(0010,0032)	3	-	(0010,0032)	
Patient's Sex	(0010,0040)	2	x	(0010,0040)	(0010,0040)
Patient's Insurance Plan Code Sequence (Uses universal sequence match)	(0010,1050)	3	-	(0010,1050)	
>Code Value	(0008,0100)	1C			
>Code Scheme Designator	(0008,0102)	1C			
>Code Scheme Version	(0008,0103)	3			
>Code Meaning	(0008,0104)	3			
Patient's Age	(0010,1010)	3	x	(0010,1010)	
Patient's Size	(0010,1020)	3	x	(0010,1020)	
Patient's Weight	(0010,1030)	2	x	(0010,1030)	
Patient's Address	(0010,1040)	3	x	(0010,1040)	
Military Rank	(0010,1080)	3	x	(0010,1080)	
Branch of Service	(0010,1081)	3	-	(0010,1081)	
Country of Residence	(0010,2150)	3	-	(0010,2150)	
Region of Residence	(0010,2152)	3	-	(0010,2152)	
Patient's Telephone Numbers	(0010,2154)	3	-	(0010,2154)	
Ethnic Group	(0010,2160)	3	x	(0010,2160)	
Occupation	(0010,2180)	3	-	(0010,2180)	

Attribute name	Tag	Return Key Type	UI	IOD	MPPS
Patient's Religious Preference	(0010,21F0)	3	-	(0010,21F0)	
Patient Comments	(0010,4000)	3	x	(0010,4000)	
Patient Data Confidentiality Constraint Description	(0040,3001)	2	x	(0040,3001)	
Patient Medical					
Medical Alerts	(0010,2000)	2	x	(0010,2000)	
Contrast Allergies	(0010,2110)	2	x	(0010,2110)	
Pregnancy Status	(0010,21C0)	2	x	(0010,21C0)	
Smoking Status	(0010,21A0)	3	x	(0010,21A0)	
Last Menstrual Date	(0010,21D0)	3	x	(0010,21D0)	
Additional Patient History	(0010,21B0)	3	x	(0010,21B0)	
Special Needs	(0038,0050)	2	x	(0038,0050)	
Patient State	(0038,0500)	2	x	(0038,0500)	
Patient Relationship					
Referenced Study Sequence <i>(Uses universal sequence match)</i>	(0008,1110)	3	-		
>Referenced SOP Class UID	(0008,1150)	1C	-		
>Referenced SOP Instance UID	(0008,1155)	1C	-		
Referenced Visit Sequence <i>(Uses universal sequence match)</i>	(0008,1125)	3	-		
>Referenced SOP Class UID	(0008,1150)	1C	-		
>Referenced SOP Instance UID	(0008,1155)	1C	-		
Referenced Patient Alias Sequence <i>(Uses universal sequence match)</i>	(0038,0004)	3	-		
>Referenced SOP Class UID	(0008,1150)	1C	-		
>Referenced SOP Instance UID	(0008,1155)	1C	-		

4.2.3.3.2.3.4 Status Codes of the Worklist C-FIND-RSP

The Worklist SCU interprets the following status codes:

Table 51: Status Codes "Update Worklist"

Service Status	Meaning	Error Codes	Related Fields
Refused	Out of Resources	A700	(0000,0902)
Failed	Identifier does not match SOP Class	A900	(0000,0901)

Service Status	Meaning	Error Codes	Related Fields
			(0000,0902)
	Unable to process	Cxxx	(0000,0901) (0000,0902)
Cancel	Matching terminated due to Cancel request	FE00	None
Success	Matching is complete - No final Identifier is supplied	0000	None
Pending	Matches are continuing - Current Match is supplied and any Optional Keys were supported in the same manner as Required Keys	FF00	Identifier
	Matches are continuing - Warning that one or more Optional Keys were not supported for existence and/or matching for this identifier	FF01	Identifier

4.2.3.3.3 Activity – “Create Modality Performed Procedure”

4.2.3.3.3.1 Description and Sequencing of Activities

A patient is registered by the Patient Registration “Exam” action. From this event the trigger to create a MPPS Instance is derived. The related Instance is then immediately communicated to the configured RIS system. An association is established and the MPPS Instance is sent.

4.2.3.3.3.2 Proposed Presentation Contexts

The Biograph Vision DICOM application will propose Presentation Contexts as shown in the following table:

Table 52: Proposed Presentation Contexts for Workflow AE

Abstract Syntax		Transfer Syntax		Role	Extended Negotiation
Name	UID	Name List	UID List		
Modality Performed Procedure Step	1.2.840.10008.3.1.2.3.3	Implicit VR Little Endian	1.2.840.10008.1.2	SCU	None
		Explicit VR Little Endian	1.2.840.10008.1.2.2		
		Explicit VR Big Endian	1.2.840.10008.1.2.1		

4.2.3.3.3.3 SOP specific Conformance for SOP Classes

Attributes used for the Performed Procedure Step N-CREATE

The DICOM Modality Performed Procedure Step SCU informs the remote SCP when the examination of a scheduled procedure step will be performed (i.e., the patient is registered). The N-CREATE message is sent when the examination is started with successful registration of patient data. The following table describes the supported attributes for a N-CREATE message.

Table 53: Performed Procedure Step N-CREATE Attributes

Attribute name	Tag	Required Type	Value
SOP Common			
Specific Character Set	(0008,0005)	1C	from MWL or created
Performed Procedure Step Relationship			
Scheduled Step Attribute Sequence	(0040,0270)	1	
>Study Instance UID	(0020,000D)	1	from MWL or created
>Referenced Study Sequence	(0008,1110)	2	from MWL or zero length
>>Referenced SOP Class UID	(0008,1150)	1C	
>>Referenced SOP Instance UID	(0008,1155)	1C	
>Accession Number	(0008,0050)	2	from MWL or user input
>Placer Order Number / Imaging Service Request	(0040,2016)	3	from MWL or zero length
>Filler Order Number / Imaging Service Request	(0040,2017)	3	from MWL or zero length
>Requested Procedure ID	(0040,0001)	2	from MWL or user input
>Requested Procedure Description	(0032,1060)	2	from MWL or zero length
>Scheduled Procedure Step ID	(0040,0009)	2	from MWL or zero length
>Scheduled Procedure Step Description	(0040,0007)	2	from MWL or zero length
>Scheduled Protocol Code Sequence	(0040,0008)	2	from MWL or zero length
>>Code Value	(0008,0100)	1C	
>>Coding Scheme Designator	(0008,0102)	1C	
>>Code Scheme Version	(0008,0103)	3	
>>Code Meaning	(0008,0104)	3	
Patient's Name	(0010,0010)	2	from MWL or user input
Patient ID	(0010,0020)	2	from MWL or user input or created
Patient's Birth Date	(0010,0030)	2	from MWL or user input
Patient's Sex	(0010,0040)	2	from MWL or user input
Referenced Patient Sequence	(0008,1120)	2	from MWL or zero length

Attribute name	Tag	Required Type	Value
>Referenced SOP Class UID	(0008,1150)	1C	
>Referenced SOP Instance UID	(0008,1155)	1C	
Performed Procedure Step Information			
Performed Procedure Step ID	(0040,0253)	1	from SPS ID or created
Performed Station AE Title	(0040,0241)	1	own AE Title
Performed Station Name	(0040,0242)	2	own hostname
Performed Location	(0040,0243)	2	from SPS Location or zero length
Performed Procedure Step Start Date	(0040,0244)	1	created
Performed Procedure Step Start Time	(0040,0245)	1	created
Performed Procedure Step Status	(0040,0252)	1	IN PROGRESS
Performed Procedure Step Description	(0040,0254)	2	from SPS Description or zero length
Performed Procedure Type Description	(0040,0255)	2	zero length
Procedure Code Sequence	(0008,1032)	2	from Requested Procedure Code or zero length
>Code Value	(0008,0100)	1C	
>Code Scheme Designator	(0008,0102)	1C	
>Code Scheme Version	(0008,0103)	3	
>Code Meaning	(0008,0104)	3	
Performed Procedure Step End Date	(0040,0250)	2	zero length
Performed Procedure Step End Time	(0040,0251)	2	zero length
Image Acquisition Results			
Modality	(0008,0060)	1	CT
Study ID	(0020,0010)	2	from Requested Procedure ID or created
Performed Protocol Code Sequence	(0040,0260)	2	from Scheduled Protocol Code Sequence or <zero length>
>Code Value	(0008,0100)	1C	
>Coding Scheme Designator	(0008,0102)	1C	

Attribute name	Tag	Required Type	Value
>Coding Scheme Version	(0008,0103)	3	
>Code Meaning	(0008,0104)	3	
Performed Series Sequence	(0040,0340)	2	
>Performing Physician's Name	(0008,1050)	2C	from MWL or user input
>Operator's Name	(0008,1070)	2C	User input
>Series Instance UID	(0020,000E)	1C	created
>Series Description	(0008,103E)	2C	<zero length>
>Retrieve AE Title	(0008,0054)	2C	<zero length>
>Protocol Name	(0018,1030)	1C	from organ program
>Referenced Image Sequence	(0008,1140)	2C	<zero length>
>Referenced Non-Image Composite SOP Instance Sequence	(0040,0220)	2C	<zero length>
Radiation Dose (retired, but still supported)			
Anatomic Structure, Space or Region Sequence	(0008,2229)	3	<zero length>
Total Time of Fluoroscopy	(0040,0300)	3	<zero length>
Total Number of Exposures	(0040,0301)	3	<zero length>
Distance Source to Detector	(0018,1110)	3	<zero length>
Distance Source to Entrance	(0040,0306)	3	<zero length>
Entrance Dose	(0040,0302)	3	<zero length>
Entrance Dose in mGy	(0040,8302)	3	<zero length>
Exposed Area	(0040,0303)	3	<zero length>
Image and Fluoroscopy Area Dose Product	(0018,115E)	3	<zero length>
Comments on Radiation Dose	(0040,0310)	3	<zero length>

Attribute name	Tag	Required Type	Value
Exposure Dose Sequence	(0040,030E)	3	<zero length>
Billing and Material Management Code			
Billing Procedure Step Sequence	(0040,0320)	3	<zero length>
Film Consumption Sequence	(0040,0321)	3	
>Number of Films	(2100,0170)	3	<zero length>
>Medium Type	(2000,0030)	3	<zero length>
>Film Size ID	(2010,0050)	3	<zero length>
Billing Supplies and Devices Sequence	(0040,0324)	3	
>Billing Item Sequence	(0040,0296)	3	<zero length>
>Quantity Sequence	(0040,0293)	3	
>>Quantity	(0040,0294)	3	<zero length>
>>Measuring Units Sequence	(0040,0295)	3	<zero length>

Status Codes of the Performed Procedure Step N-CREATE

The Performed Procedure Step SCU interprets the following status values:

Table 54: N-SET Response Status

Service Status	Meaning	Status Codes (0000,0900)
Failure	Processing Failure	0110
	No such attribute	0105
	Invalid attribute value	0106
	Duplicate SOP Instance	0111
	No such SOP Instance	0112
	No such SOP Class	0118
	Class instance conflict	0119
	Missing attribute	0120
	Missing attribute value	0121
	Resource limitation	0213
Success	MPPS Instance created	0000

4.2.3.3.4 Activity – “Update Modality Performed Procedure”

4.2.3.3.4.1 Description and Sequencing of Activities

With the MPPS UI the status of the MPPS Instance can be set to “COMPLETED” or “DISCONTINUED”. During performance of the procedure the status will remain “IN PROGRESS”.

4.2.3.3.4.2 Proposed Presentation Contexts

For " Update Modality Performed Procedure " the same Presentation Contexts as with “Create Modality Performed Procedure” are proposed.

4.2.3.3.4.3 SOP specific Conformance for SOP Classes

Attributes used for the Performed Procedure Step N-SET

The Biograph Vision DICOM performed procedure step SCU informs the remote SCP about the performed examination and its status. The N-Set message is sent once for each reconstruction of acquisition data with status "IN PROGRESS". The N-SET message is sent on user input with status "COMPLETED" or "DISCONTINUED", respectively. This is intended to be used when the examination is finished with status "COMPLETED" or when the examination could not be completed with status "DISCONTINUED" (already sent automatically when examination is ended via End Exam and no acquisition was done). The following table describes the supported attributes for a N-SET message.

Table 55: Performed Procedure Step N-SET Attributes

Attribute name	Tag	Required Type	Value
Performed Procedure Step Information			
Performed Procedure Step Status	(0040,0252)	3	IN PROGRESS or COMPLETED or DISCONTINUED (see above)
Performed Procedure Step Description	(0040,0254)	3	from SPS Description or user input
Procedure Code Sequence	(0008,1032)	3	from Requested Procedure Code or empty on user change (see IHE Technical Framework Y3, App. C Note 6)
>Code Value	(0008,0100)	1C	
>Coding Scheme Designator	(0008,0102)	1C	
>Coding Scheme Version	(0008,0103)	3	
>Code Meaning	(0008,0104)	3	
Performed Procedure Step End Date	(0040,0250)	1	created or zero length
Performed Procedure Step End Time	(0040,0251)	1	created or zero length

Attribute name	Tag	Required Type	Value
Comments on the Performed Procedure Steps	(0040,0280)	3	user input
Image Acquisition Results			
Performed Protocol Code Sequence	(0040,0260)	3	from Scheduled Protocol Code SQ or user input
>Code Value	(0008,0100)	1C	
>Coding Scheme Designator	(0008,0102)	1C	
>Coding Scheme Version	(0008,0103)	3	
>Code Meaning	(0008,0104)	3	
Performed Series Sequence	(0040,0340)	1	
>Performing Physician's Name	(0008,1050)	2C	from MWL or user input [empty if Study Split is used]
>Protocol Name	(0018,1030)	1C	name of Scan Protocol (Siemens standard or user defined) [dummy if Study Split is used]
>Operator's Name	(0008,1070)	2C	user input [empty if Study Split is used]
>Series Instance UID	(0020,000E)	1C	created [dummy if Study Split is used]
>Series Description	(0008,103E)	2C	range name with generated reconstruction information or user input [empty if Study Split is used]
>Retrieve AE Title	(0008,0054)	2C	from Storage Commitment RSP or zero length
>Referenced Image Sequence	(0008,1140)	2C	created [empty if Study Split is used]
>>Referenced SOP Class UID	(0008,1150)	1C	
>>Referenced SOP Instance UID	(0008,1155)	1C	

Attribute name	Tag	Required Type	Value
>Referenced Standalone SOP Instance Sequence	(0040,0220)	2C	zero length
Radiation Dose (retired, but still supported)			
Total Number of Exposures	(0040,0301)	3	
Entrance Dose in mGy	(0040,8302)	3	accumulated over complete procedure step
Image and Fluoroscopy Area Dose Product	(0018,115E)	3	accumulated over complete procedure step (dGy*cm2)
Exposure Dose Sequence ¹	(0040,030E)	3	one item for each irradiation event (acquisition or fluoro)
>Radiation Mode	(0018,115A)	3	
>KVP	(0018,0060)	3	peak KV used for this event (KV)
>X-ray Tube Current in μ A	(0018,8151)	3	tube current used for this event
>Exposure Time	(0018,1150)	3	time of x-ray in ms for this event
>Filter Type	(0018,1160)	3	"WEDGE_2" "WEDGE_3" "WEDGE_2_3" "SN_DE" "FLAT" "AU_DESF" "SN_DESF" "AUSN_DESF" or combinations of "WEDGE_*" and "SN_DE"
>Comments on Radiation Dose	(0040,0310)	3	additional acquisition specific information (Entrance Dose, Dose Area Product, X-Ray Filter, etc.) as text
>CTDIVol ²	(0018,9345)	2C	
>CTDI Phantom Type Code Sequence ²	(0018,9346)	3	created

¹ This sequence added is not part of this module as per DICOM standard. Support for this sequence in this module is additional and is not conforming to DICOM standard.

² As per the DICOM standard this attribute is not a part of the Exposure Dose Sequence.

Attribute name	Tag	Required Type	Value
>>Code Value ¹	(0008,0100)	1	
>>Coding Scheme Designator ¹	(0008,0102)	1	
>>Code Meaning ¹	(0008,0104)	1	
>Private Creator ¹	(0019,00xx)		SIEMENS CT DOSE
>Dose Length Product ¹	(0019,xx10)		
>Comments On Radiation Dose	(0040,0310)	3	e.g.: Topogram: kV=120 mAs=95 CTDIvol=0.13 DLP=3 PhantomType=32cm
>Organ Dose ¹	(0040,0316)	3	
Billing and Material Management Code			
Film Consumption Sequence	(0040,0321)	3	
>Number of Films	(2100,0170)	3	
>Medium Type	(2000,0030)	3	
>Film Size ID	(2010,0050)	3	
Billing Supplies and Devices Sequence	(0040,0324)	3	user input in Examination Card (example values below) or MPPS window
>Billing Item Sequence	(0040,0296)	3	
>>Code Value	(0008,0100)	1C	e.g., contrast media code
>>Code Scheme Designator	(0008,0102)	1C	e.g., contrast media catalog
>>Code Meaning	(0008,0104)	1C	e.g., contrast media name
>Quantity Sequence	(0040,0293)	1C	
>>Quantity	(0040,0294)	3	e.g., volume of contrast media

¹ As per the DICOM standard this attribute is not a part of the Exposure Dose Sequence.

Attribute name	Tag	Required Type	Value
>>Measuring Units Sequence	(0040,0295)	3	
>>>Code Value	(0008,0100)	1C	e.g., cm3
>>>Code Scheme Designator	(0008,0102)	1C	e.g., UCUM
>>>Code Scheme Version	(0008,0103)	1C	e.g., 1.4
>>>Code Meaning	(0008,0104)	1C	e.g., cm3

Status Codes of the Performed Procedure Step N-SET

The Performed Procedure Step SCU interprets the following status values:

Table 56: N-SET Response Status

Service Status	Meaning	Status Codes (0000,0900)
Failure	Processing Failure: Performed Procedure Step Object may no longer be updated	0110
	No such attribute	0105
	Invalid attribute value	0106
	No such SOP Instance	0112
	Invalid object instance	0117
	No such SOP Class	0118
	Class instance conflict	0119
	Missing attribute value	0121
	Resource limitation	0213
Success	MPPS instance set	0000

Performed Procedure Step ID sometimes has to be generated locally, e.g. for Unscheduled case.

The attribute "Performed Procedure Step ID" (0040,0235) will be encoded based on "YYYYMMDDHHMMSS". This date and time are based on the time when the first image is acquired. The "Performed Procedure Step ID" stays the same for all acquired or derived images as long as the patient is re-registered. A re-registered patient with a new study or new series within the existing study will get a newly assigned "Performed Procedure Step ID".

4.2.3.4 Association Acceptance Policy

N/A

4.3 Network Interfaces

4.3.1 Physical Network Interface

The DICOM Interface of Biograph Vision provides DICOM TCP/IP Network Communication Support and uses the TCP/IP protocol stack from the operating system. It uses the MergeCOM subroutine library. All available Ethernet interfaces are supported.

4.3.2 Additional Protocols

N/A

4.3.3 IPv4 and IPv6 Support

syngo supports the transfer of the DICOM images over the network nodes and workstations using IPv4 and optionally IPv6 protocols using Transfer/Send to features.

Exporting of the images to a network shared folder using Export to offline feature using IPv4 and optionally using IPv6 protocols.

4.4 Configuration

4.4.1 AE Title / Presentation Address Mapping

4.4.1.1 Local AE Titles

According to the DICOM Standard, the AET string can be up to 16 characters long and must not contain any extended characters, only 7-bit ASCII characters (excluding Control Characters).

Note: The current implementation of Biograph Vision does not allow Spaces and special characters (like &<> ") in the AE title string.

Change of the default AE Titles chosen by the system can be performed in the Service UI under "Configuration / DICOM / General" item - first page.

Table 57: Default AET Characteristics

Application Entity		Default AE Title	TCP/IP Port
Storage AE	Verification SCU	<i>RANDOM_STR</i> (if unencrypted) <i>RANDOM_STR_S</i> (if encrypted)	-
	Verification SCP		104 (fixed, unencrypted) 2762 (fixed, encrypted)
	Storage SCU		-
	Storage SCP		104 (fixed, unencrypted) 2762 (fixed, encrypted)
	Storage Commitment SCU		-
	Query/Retrieve SCU		-
	Query/Retrieve SCP		104 (fixed, unencrypted)

			2762 (fixed, encrypted)
Print AE	Print SCU	RANDOM_STR	-
Workflow AE	Worklist SCU	RANDOM_STR	-
	MPPS SCU		-

Port 2762 is used for Secure DICOM Communication and Port 104 is used for Unsecure DICOM Communication. There are two AETs for Storage SCP, Verification SCP and Query/Retrieve SCP. *RANDOM_STR* denotes the random AET value is randomly generated. *RANDOM_STR_S* denotes random AET value for Secure DICOM communication.

4.4.1.2 Remote AE Title/Presentation Address Mapping

When "trusted host functionality" is enabled, all external AE Titles must be configured to be able to communicate with Biograph Vision.

For each remote AE the following data and capabilities can be configured:

Table 58: Remote AE Configuration Items

Remote AE configuration item	Comment
Host Name	As defined in the network domain. This has to be configured also for any DICOM AE that wishes to connect to SCP services of .
TCP/IP address	As defined in the network domain. This has to be configured also for any DICOM AE that wishes to connect to SCP services of .
Logical Name	Name for the AE used in the user interfaces of the applications.
AE Title	AET, as provided by network administration
Port Number	Port Number, as provided by network administration
Supports Enhanced Data	Configures capability of remote node to handle DICOM Enhanced data (e.g. Enhanced CT Image). Default value is "unchecked".
If Storage Service support is checked	
Transfer Syntax	Selection of uncompressed transfer Syntaxes supported by remote AE
Compression	Selection of additional compression Syntaxes supported for remote AE
Default Node	"First default"/" second default"/ ["no default"] - activating this feature will show "Send to <logical name>" in the Transfer tool menu for quick access.
Preference Node	When checked, the remote AE will be assigned to a keyboard shortcut key.
Archive Node	When checked, sending to remote AET will set status of a(archived), else s(sent) is indicated.
Default Archive	When checked, the remote AE will be listed as default archive in User interfaces.
Graphics in Pixel Data	When checked, the DICOM overlay will not be encoded in attribute (60xx,3000) Overlay Data, but masked in the "unused bits" of the pixel data (only for uncompressed transfer syntaxes). For backwards compatibility with legacy AE.
Select Storage Commitment node	Select a previously configured node as target for Storage Commitment when sending DICOM objects to the configured AE. Default is the same node as to which the Objects are sent.
Select Storage Commitment AET	Select AET that corresponds to the above selected node that receives the Storage Commitment request. Default is the above specified "AE Title".

Remote AE configuration item	Comment
SC Result in same association	When checked the DICOM application will await the Storage Commitment N-EVENT-REPORT on the same association. Default is "not checked" (= different association).
SC result timeout	Timeout in hours and minutes to wait at the open association. Default: 01:00 (hour:minutes).
Support Asynchronous Transfer	Use asynchronous mode for sending/receiving DICOM objects. Default is "not checked".
Maximum Operation Performed and Invoked	Window size if asynchronous mode is "checked", i.e. maximum operations performed/invoked. Default: 10.
If Storage Commitment Service support is checked	
N/A	The related Storage Commitment configuration is either in the Storage section of the same AET or different AET (in case the current AET is only Storage Commitment Provider).
If Query Service support is checked	
provides DICOM Query model	The Query models supported by this AET can be selected. When possible, the STUDY ROOT Information model should preferably be configured
If Retrieve Service support is checked	
N/A	Checking Retrieve support for an AET is the only needed configuration item. This will allow access to the "Import" feature in the Query result browser.
If Modality Worklist Service support is checked	
Query Waiting time	The time to wait for the C-FIND-RSP after sending the C-FIND-RQ (default 20 sec.)
Max Query Match Number	The maximum number of entries accepted in one worklist (default is 200)
Query Interval	The time between two C-FIND-RQ to the Hospital Information system (default is 60 min, minimum is 3 min, maximum is 1440 min i.e., 24 hours)
Automatic removal of canceled/rescheduled Requests	Checking this item will remove all unused entries from the scheduler list prior to inserting the worklist responses with each query.

4.4.2 Parameters

System parameters can be changed in the Service UI under "Configuration / DICOM / General" item.

Table 59: General parameter settings and timeouts

Parameters					
General Time-out Values					
Parameter	Configurable	Default Value [sec]	Min [sec]	Max [sec]	Comment
Accepting/Rejecting an Association Request	Yes	60	15	600	Wait for an Association Request or wait for a Peer to shut down the Association
Association Open	Yes	60	15	600	Wait for a reply to an Association

Parameters					
Request					Accept Request
Association Close Request	Yes	60	15	600	Wait for a reply to an Association Release Request
Accepting a Message over Network	Yes	60	15	600	Wait for a Network Write to be accepted
Waiting for Data between TCP/IP Packets	Yes	60	15	600	Wait for Data between TCP/IP packets
Response from Remote Node for Storage/Query/Retrieve	Yes	600	15	600	Time between Service Request and Service Response
Accept network connect	Yes	60	15	600	
General Transfer Setting					
Simultaneous DICOM associations	Yes	10	1	10	Number of simultaneous associations running.
Maximum PDU Size	Yes	32kByte	4kByte	1MByte	Proposed PDU size, each selectable value is doubled from previous, starting with 4kB. Additionally for optimization for some networks 28kByte are provided.
AE Specific Parameters (local)					
Update worklist in background	Yes	off			Get worklist updates automatically, not just manually
Ask for time range in manual update	Yes	off			User defined time range possible in manual worklist update
Update worklist in background	Yes	off			Get worklist updates automatically, not just manually
Time range	Yes	Today			Previous and following days can be added for broad worklist update
Modality (worklist)	Yes	CT			Modality value to use in broad worklist update
AET (worklist)	Yes	Local Site AET			Scheduled Station AE Title value to use in broad worklist update
From RIS	Yes	Set in Service			RIS (WL SCP) node to be used for worklist update
MPPS node	Yes	Set in Service			MPPS node to be used for MPPS messages
WLOFF	Yes	off			Do not send worklist update requests

For **remote AE specific** configurable parameters see Table 58: Remote AE Configuration Items.

5 Media Interchange

5.1 Implementation Model

5.1.1 Application Data Flow Diagram

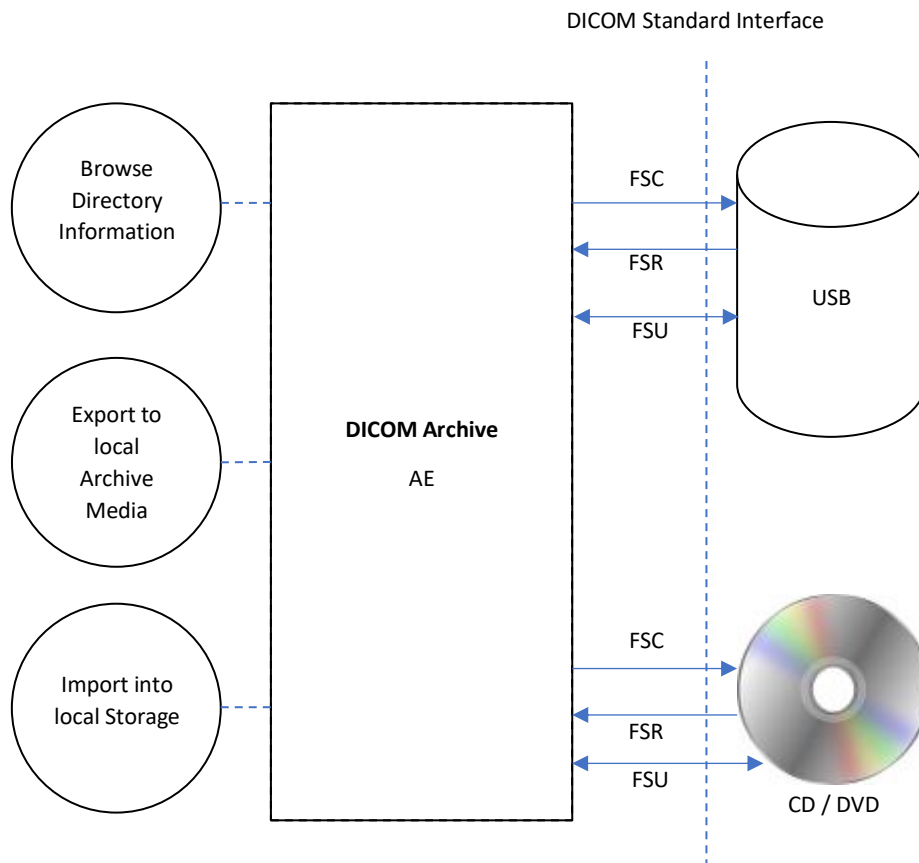

Figure 8: Media Interchange Application Data Flow Diagram

The DICOM Archive AE will serve as an interface to the CD-R/DVD/USB offline medium device.

The DICOM Archive AE will support the 120mm CD-R, DVD medium.

Note: For Export on DVD only media of type DVD-R are supported.

The FSU role will update new SOP Instances only to media with pre-existing File-sets conforming to the Application Profiles supported.

The contents of the DICOMDIR will temporarily be stored in Archive-Database. All SOP Classes defined in Table 1: Network Services are supported for the Import/Export functionality.

5.1.2 Functional Definitions of AEs

The Biograph Vision DICOM Offline Media Storage application consists of the DICOM Archive application entity serving all interfaces to access offline media. The DICOM Archive application is capable of

- creating a new File-set onto an unwritten medium (Export to...)
- updating an existing File-set by writing new SOP Instances onto the medium (Export to...)
- importing SOP Instances from the medium onto local storage
- reading the File-set’s DICOMDIR information temporarily into database and pass it to display applications.

5.1.3 Sequencing of Real World Activities

The DICOM Archive AE will not perform transfers until the Directory information of the DICOMDIR is completely read in and displayed in the Browser.

When performing updates, the SOP instances are checked for existence before updating. Duplicate instances will be avoided.

5.1.4 File Meta Information for Implementation Class and Version

The Biograph Vision software is using some common Implementation Identifying Information for Networking and Media Interchange.

For detailed Implementation Class UID and Implementation Version Name within File Meta Information, please refer to common Table 3: Implementation Identifying Information in the “Conformance Statement Overview”.

For File Meta Information Version, please see the following table.

Table 60 : File Meta Information Version – Media Interchange

File Meta Information Version	00\01
--------------------------------------	-------

5.2 AE Specifications

5.2.1 DICOM Archive – Specification

The DICOM Archive AE provides Standard conformance to Media Storage Service Class (Interchange Option).

Details are listed in following Table:

Table 61 : Application profiles, Activities, and Roles for DICOM Archive

Application Profiles Supported	Real-World Activity	Role	SC Option
PRI-SYNGO-CD	Browse Directory Information	FSR	Interchange
PRI-SYNGO-DVD	Import into local Storage	FSR	Interchange
PRI-SYNGO-USB ¹	Export to local Archive Media	FSC, FSU	Interchange
AUG-GEN-CD ²			
AUG-GEN-DVD-JPEG ³			

¹ The USB Support is possible when the USB is enabled with Browser support in the Local service page.

² With no Private SOP Class used, the PRI-SYNGO-CD/DVD/USB profile definitions are appropriate to describe the augmentation of the related STD Profiles

³ With no Private SOP Class used, the PRI-SYNGO-CD/DVD/USB profile definitions are appropriate to describe the augmentation of the related STD Profiles

Application Profiles Supported	Real-World Activity	Role	SC Option
AUG-GEN-USB-JPEG ¹			
STD-GEN-CD	Browse Directory Information	FSR	Interchange
STD-GEN-DVD-JPEG	Import into local Storage	FSR	Interchange
STD-GEN-DVD-J2K			
STD-GEN-USB-JPEG			
STD-GEN-USB-J2K			

On syngo-based products the Private syngo Profile (e.g. PRI-SYNGO-CD) will be preferably used by the system. The General-Purpose Interchange Profiles (STD-GEN-xxx) will be supported with read capability of the related media. More specific standard profiles like those in Ultrasound Class of Application Profiles (STD-US), CT and MR Image Profiles (STD-CTMR-xxx), Basic Cardiac X-Ray Angiographic Studies on CD-R Media Profile (STD-XABC-CD) and 1024 X-Ray Angiographic Profiles (STD-XA1K-xxx) will be supported with read capability of the related media in as far as they form a subset of more general PRI-SYNGO-xxx Profiles.

5.2.1.1 File Meta Information for the Application Entity

There is no Source Application Entity Title in use for the DICOM Archive AE, corresponding optional File Meta Information attribute will not be written.

5.2.1.2 Real-World Activities

5.2.1.2.1 Activity "Browse Directory Information"

The DICOM Archive AE acts as FSR using the interchange option when requested to read the media directory.

The DICOM Archive AE will read the DICOMDIR and insert those directory entries that are valid for the application profiles supported into a local database. The database can then be used for browsing media contents.

Note: Icon Image Sequence is also supported in DICOMDIR. But only those Icon Images with Bits Allocated (0028,0100) equal to 8 and size of 64x64 or 128x128 pixels are imported into database and are visible in the Browser.

5.2.1.2.1.1 Media Storage Application Profile

See Table 61 : Application profiles, Activities, and Roles for DICOM Archive in section 5.2.1 for the Application Profiles listed that invoke this Application Entity for the Browse Directory Information activity.

For all listed profiles, Basic Directory IOD with Explicit VR Little Endian Uncompressed Transfer Syntax is supported to read the media directory.

5.2.1.2.2 Activity: Import into local Storage

The DICOM Archive application acts as FSR using the interchange option when being requested to read SOP Instances from the medium into the local storage.

The SOP Instance(s) selected from the media directory will be copied into the local storage. Only SOP Instances, that are valid for the application profile supported and are listed as supported by the Storage AE Conformance section (Network DCS, 4.2.1), can be retrieved from Media Storage.

¹ With no Private SOP Class used, the PRI-SYNGO-CD/DVD/USB profile definitions are appropriate to describe the augmentation of the related STD Profiles

5.2.1.2.2.1 Media Storage Application Profile

See Table 61 : Application profiles, Activities, and Roles for DICOM Archive” in section 5.2.1 for the Application Profiles listed that invoke this Application Entity for the Import into Local Storage activity.

For media conforming to the STD-GEN-CD Profile the following SOP Classes will be supported as FSR:

Table 62: STD-GEN-CD profile supported SOP Classes

Information Object Definition / SOP Class UID	Transfer Syntax UID
Any image SOP Class detailed in “Table 1: Network Services” section „Transfer (Image SOP Class)“.	Explicit VR Little Endian Uncompressed 1.2.840.10008.1.2.1
Any image SOP Class detailed in “Table 1: Network Services” section „Transfer (Non-Image SOP Class)“.	Explicit VR Little Endian Uncompressed 1.2.840.10008.1.2.1

For media conforming to the STD-GEN-DVD-JPEG, STD-GEN-USB-JPEG, STD-GEN-DVD-J2K, STD-GEN-USB-J2K Profile the following SOP Classes will be supported as FSR:

Table 63: STD-GEN-DVD-JPEG, STD-GEN-USB-JPEG STD-GEN-DVD-J2K, STD-GEN-USB-J2K profile supported SOP Classes

Information Object Definition / SOP Class UID	Transfer Syntax UID
Any image SOP Class detailed in “Table 1: Network Services” section „Transfer (Image SOP Class)“.	Explicit VR Little Endian Uncompressed 1.2.840.10008.1.2.1
	JPEG Lossless Process 14 (selection value 1) 1.2.840.10008.1.2.4.70
	JPEG Lossy (baseline or extended) 1.2.840.10008.1.2.4.50 1.2.840.10008.1.2.4.51
	JPEG 2000 Lossless 1.2.840.10008.1.2.90
	JPEG 2000 1.2.840.10008.1.2.91
	Any image SOP Class detailed in “Table 1: Network Services” section „Transfer (Non-Image SOP Class)“.

5.2.1.2.3 Activity: Export to local Archive Media

The DICOM Archive application acts as FSU (for media with existing DICOM file-set) or FSC (media not initialized) using the interchange option when requested to copy SOP Instances from the local storage to local Archive Medium.

The DICOM Archive application will receive a list of SOP Instances to be copied to the local archive medium. According to the state of the medium inserted (new medium, Medium with DICOM file-set) the validity of the SOP Instances according to the applicable profile is checked. Only valid SOP Instances are accepted.

The DICOM Archive application will not finalize the medium.

With the resizing feature of the Biograph Vision DICOM application, a copy of images in Cardiac Format (512x512, 8Bit) can be written onto medium.

5.2.1.2.3.1 Media Storage Application Profile

See Table 61 : Application profiles, Activities, and Roles for DICOM Archive” in section 5.2.1 for the Application Profiles listed that invoke this Application Entity for the Export to Local Archive Media activity.

The Biograph Vision DICOM application does not claim conformance to STD application profiles as FSC or FSU, because there is no way to restrict exported IODs to Standard IODs only. Augmented profiles are available as FSC/FSU handling Standard Extended IODs (see 5.3.1).

5.3 Augmented and Private Application Profiles

5.3.1 Augmented Application Profiles

5.3.1.1 AUG-GEN-CD

5.3.1.1.1 SOP Class Augmentations

The STD-GEN-CD profile is augmented by support of Standard Extended SOP Classes corresponding to the supported Standard SOP Classes.

This is mainly relevant for objects created by the system. These will typically belong to Standard Extended SOP Classes, as documented in the Annex.

Restriction to export with uncompressed Transfer Syntax is supported by corresponding configuration item.

The operator is also supported to retain the AUG-GEN-CD profile by default configuration to exclude Private SOP Class from implicit export. It is only by deliberate explicit action that private profile media will be created (see Private Application Profiles).

5.3.1.1.2 Directory Augmentations

For extensions to the Directory, please see the definitions in corresponding PRI-SYNGO Application Profile Class (5.3.2.3.3).

Within the AUG-GEN-CD profile, private attributes will not be present in DICOMDIR because no Private SOP Class instances are written to the medium.

5.3.1.1.3 Other Augmentations

Not applicable.

5.3.1.2 AUG-GEN-DVD-JPEG

5.3.1.2.1 SOP Class Augmentations

The STD-GEN-DVD-JPEG profile is augmented by support of Standard Extended SOP Classes corresponding to the supported Standard SOP Classes.

This is mainly relevant for objects created by the system. These will typically belong to Standard Extended SOP Classes, as documented in the Annex.

Restriction to export with uncompressed Transfer Syntax, lossless or lossy JPEG is supported by corresponding configuration item. Only following Transfer Syntaxes will be supported for AUG-GEN-DVD-JPEG:

Table 64: AUG-GEN-DVD-JPEG profile supported SOP Classes

Information Object Definition / SOP Class UID	Transfer Syntax UID
Any image SOP Class detailed in “Table 1: Network Services” section „Transfer (Image SOP Class)“.	Explicit VR Little Endian Uncompressed 1.2.840.10008.1.2.1

Information Object Definition / SOP Class UID	Transfer Syntax UID
	JPEG Lossless Process 14 (selection value 1) 1.2.840.10008.1.2.4.70 JPEG Lossy (baseline or extended) 1.2.840.10008.1.2.4.50 1.2.840.10008.1.2.4.51
Any image SOP Class detailed in “Table 1: Network Services” section „Transfer (Non-Image SOP Class)“.	Explicit VR Little Endian Uncompressed 1.2.840.10008.1.2.1

The operator is supported to retain the AUG-GEN-DVD-JPEG profile by default configuration to exclude Private SOP Class from implicit export. It is only by deliberate explicit action that private profile media will be created (see Private Application Profiles).

5.3.1.2.2 Directory Augmentations

For extensions to the Directory, please see the definitions in corresponding PRI-SYNGO Application Profile Class (5.3.2.3.3).

Within the AUG-GEN-DVD-JPEG profile, private attributes will not be present in DICOMDIR because no Private SOP Class instances are written to the medium.

5.3.1.2.3 Other Augmentations

Not applicable.

5.3.1.3 AUG-GEN-USB-JPEG

5.3.1.3.1 SOP Class Augmentations

The STD-GEN-USB-JPEG profile is augmented by support of Standard Extended SOP Classes corresponding to the supported Standard SOP Classes.

This is mainly relevant for objects created by the system. These will typically belong to Standard Extended SOP Classes, as documented in the Annex.

Restriction to export with uncompressed Transfer Syntax, lossless or lossy JPEG is supported by corresponding configuration item. Only following Transfer Syntaxes will be supported for AUG-GEN-USB-JPEG:

Table 65: AUG-GEN-USB-JPEG profile supported SOP Classes

Information Object Definition / SOP Class UID	Transfer Syntax UID
Any image SOP Class detailed in “Table 1: Network Services” section „Transfer (Image SOP Class)“.	Explicit VR Little Endian Uncompressed 1.2.840.10008.1.2.1 JPEG Lossless Process 14 (selection value 1) 1.2.840.10008.1.2.4.70 JPEG Lossy (baseline or extended) 1.2.840.10008.1.2.4.50 1.2.840.10008.1.2.4.51
Any image SOP Class detailed in “Table 1: Network Services” section „Transfer (Non-Image SOP Class)“.	Explicit VR Little Endian Uncompressed 1.2.840.10008.1.2.1

The operator is supported to retain the AUG-GEN-USB-JPEG profile by default configuration to exclude Private SOP Class from implicit export. It is only by deliberate explicit action that private profile media will be created (see Private Application Profiles).

5.3.1.3.2 Directory Augmentations

For extensions to the Directory, please see the definitions in corresponding PRI-SYNGO Application Profile Class (5.3.2.3.3).

Within the AUG-GEN-CD profile, private attributes will not be present in DICOMDIR because no Private SOP Class instances are written to the medium.

5.3.1.3.3 Other Augmentations

Not applicable.

5.3.2 Private Application Profiles

This section will contain a syngo specific Application Profile Class. The Structure of this Application Profile is defined in Part 11 of the DICOM Standard.

It is needed to describe the requirements for Offline Media Storage of the Siemens private IOD (CSA Non-Image IOD).

5.3.2.1 Class and Profile Identification

This document defines an Application Profile class for "syngo¹" based modalities or applications.

The identifier for this class shall be PRI-SYNGO. This class is intended to be used for interchange of extended and private Information Objects via CD-R, DVD-R or USB offline media between dedicated acquisition or workstation modalities built from a common syngo architecture.

The specific application profiles in this class are shown in the table below:

Table 66: syngo private Application Profile

Application Profile	Identifier	Description
syngo System on CD-R	PRI-SYNGO-CD	Handles interchange of Composite SOP Instances and privately defined SOP Instances (Siemens Non-Image IOD)
syngo System on DVD-R	PRI-SYNGO-DVD	Handles interchange of Composite SOP Instances and privately defined SOP Instances (Siemens Non-Image IOD)
syngo System on USB (If Browser support is configured in Local service page of Biograph Vision)	PRI-SYNGO-USB	Handles interchange of Composite SOP Instances and privately defined SOP Instances (Siemens Non-Image IOD)

Equipment claiming conformance for this syngo Application Profile Class shall make a clear statement on handling of the private defined SOP Instances.

5.3.2.2 Clinical Context

This application profile facilitates the interchange of original acquired and derived images and private data related to them. Typical media interchange would be from in-lab acquisition equipment to dedicated workstations and archive systems with specific extensions to handle the private data objects (in both directions).

¹ 'syngo' is a registered trademarks of Siemens Healthineers

Additionally, images used to prepare procedures, multi-modality images (e.g. integrated US) and images derived from primary diagnostic images, such as annotations, quantitative analysis images, reference images, screen capture images may be interchanged via this profile.

5.3.2.2.1 Roles and Service Class Options

This Application Profile uses the Media Storage Service Class defined in PS 3.4 with the Interchange Option. The Application Entity shall support one or more of the roles of File Set Creator (FSC), File Set Reader (FSR), and File Set Updater (FSU), defined in PS3.10.

5.3.2.2.1.1 File Set Creator

The Application Entity acting as File Set Creator generates a File Set under the PRI-SYNGO Application Profiles.

File Set Creators shall be able to generate the Basic Directory SOP Class in the DICOMDIR file with all the subsidiary Directory Records related to the Image SOP Classes and Private SOP Classes stored in the File Set.

In case of the PRI-SYNGO-CD and PRI-SYNGO-DVD profile, the FSC shall offer the ability to allow multi-session (additional information may be subsequently added to the disc). For both profiles a multi-session media can be finalized.

Note:

A multiple volume (a logical volume that can cross multiple physical media) is not supported by this Application Profile Class. If a set of Files, e.g., a Study, cannot be written entirely on one CD-R, the FSC will create multiple independent DICOM File Sets such that each File Set can reside on a single CD-R medium controlled by its individual DICOMDIR file. The user of the FSC can opt to use written labels on the discs to reflect that there is more than one disc for this set of files (e.g. a study).

5.3.2.2.1.2 File Set Reader

The role of the File Set Reader shall be used by Application Entities which receive the transferred File Set. File Set Readers shall be able to read all the defined SOP Instance files defined for the specific Application Profiles to which a conformance claim is made, using all the defined Transfer Syntaxes.

5.3.2.2.1.3 File Set Updater

The role of the File Set Updater shall be used by Application Entities, which receive a transferred File Set and update it by the addition of processed information.

File Set Updaters shall be able to read and update the DICOMDIR file. File Set Updaters do not have to read the image/private information objects. File Set Updaters shall be able to generate any of the SOP Instance files defined for the specific Application Profiles to which a conformance claim is made, and to read and update the DICOMDIR file.

In case of the PRI-SYNGO-CD and PRI-SYNGO-DVD profile, the FSU shall offer the ability to allow multi-session (additional information can be subsequently added to the disc).

Note (for CD-R and DVD-R)

If the disc has not been finalized, the File Set Updater will be able to update information assuming there is enough space on the disc to write a new DICOMDIR file, the information, and the fundamental CD-R/DVD-R control structures. CD-R/DVD-R control structures are the structures that inherent to CD-R/DVD-R standards; see PS 3.12

5.3.2.3 PRI-SYNGO Profiles

5.3.2.3.1 SOP Classes and Transfer Syntaxes

These Application Profiles are based on the Media Storage Service Class with the Interchange Option. In the table below Transfer Syntax UID "RLE Lossless" applies only for decompression.

Table 67: SOP Classes and Transfer Syntax

Information Object Definitions	SOP Class UID	Transfer Syntax and UID	FSC	FSR	FSU
Basic Directory	1.2.840.10008.1.3.10	Explicit VR Little Endian Uncompressed 1.2.840.10008.1.2.1	M	M	M
Computed Radiology Image	1.2.840.10008.5.1.4.1.1.1	Explicit VR Little Endian Uncompressed 1.2.840.10008.1.2.1	M	M	O
		JPEG Lossless Process 14 (selection value 1) 1.2.840.10008.1.2.4.70	O	M	O
		Explicit VR Big Endian Uncompressed 1.2.840.10008.1.2.2	O	M	O
		JPEG Lossy (baseline or extended) 1.2.840.10008.1.2.4.50 1.2.840.10008.1.2.4.51	O	O	O
		RLE Lossless 1.2.840.10008.1.2.5	O	O	O
		JPEG 2000 Lossless 1.2.840.10008.1.2.90	O	O	O
		JPEG 2000 Lossy 1.2.840.10008.1.2.91	O	O	O
Digital X-Ray Image - For Presentation	1.2.840.10008.5.1.4.1.1.1.1	Explicit VR Little Endian Uncompressed 1.2.840.10008.1.2.1	M	M	O
		JPEG Lossless Process 14 (selection value 1) 1.2.840.10008.1.2.4.70	O	M	O
		Explicit VR Big Endian Uncompressed 1.2.840.10008.1.2.2	O	M	O
		JPEG Lossy (baseline or extended) 1.2.840.10008.1.2.4.50 1.2.840.10008.1.2.4.51	O	O	O
		RLE Lossless 1.2.840.10008.1.2.5	O	O	O
		JPEG 2000 Lossless 1.2.840.10008.1.2.90	O	O	O
		JPEG 2000 Lossy 1.2.840.10008.1.2.91	O	O	O
Digital X-Ray Image - For Processing	1.2.840.10008.5.1.4.1.1.1.1.1	Explicit VR Little Endian Uncompressed 1.2.840.10008.1.2.1	M	M	O
		JPEG Lossless Process 14 (selection value 1) 1.2.840.10008.1.2.4.70	O	M	O
		Explicit VR Big Endian Uncompressed 1.2.840.10008.1.2.2	O	M	O
		JPEG Lossy (baseline or extended) 1.2.840.10008.1.2.4.50 1.2.840.10008.1.2.4.51	O	O	O
		RLE Lossless	O	O	O

		1.2.840.10008.1.2.5			
Digital Mammography X-Ray Image - For Presentation	1.2.840.10008.5.1.4.1.1.1.2	Explicit VR Little Endian Uncompressed 1.2.840.10008.1.2.1	M	M	O
		JPEG Lossless Process 14 (selection value 1) 1.2.840.10008.1.2.4.70	O	M	O
		Explicit VR Big Endian Uncompressed 1.2.840.10008.1.2.2	O	M	O
		JPEG Lossy (baseline or extended) 1.2.840.10008.1.2.4.50 1.2.840.10008.1.2.4.51	O	O	O
		JPEG Lossless 1.2.840.10008.1.2.90	O	O	O
		JPEG Lossy 1.2.840.10008.1.2.91	O	O	O
		RLE Lossless 1.2.840.10008.1.2.5	O	O	O
Digital Mammography X-Ray Image - For Processing	1.2.840.10008.5.1.4.1.1.1.2.1	Explicit VR Little Endian Uncompressed 1.2.840.10008.1.2.1	M	M	O
		JPEG Lossless Process 14 (selection value 1) 1.2.840.10008.1.2.4.70	O	M	O
		Explicit VR Big Endian Uncompressed 1.2.840.10008.1.2.2	O	M	O
		JPEG Lossy (baseline or extended) 1.2.840.10008.1.2.4.50 1.2.840.10008.1.2.4.51	O	O	O
		RLE Lossless 1.2.840.10008.1.2.5	O	O	O
Digital Intra-Oral X-Ray Image - For Presentation	1.2.840.10008.5.1.4.1.1.1.3	Explicit VR Little Endian Uncompressed 1.2.840.10008.1.2.1	M	M	O
		JPEG Lossless Process 14 (selection value 1) 1.2.840.10008.1.2.4.70	O	M	O
		Explicit VR Big Endian Uncompressed 1.2.840.10008.1.2.2	O	M	O
		JPEG Lossy (baseline or extended) 1.2.840.10008.1.2.4.50 1.2.840.10008.1.2.4.51	O	O	O
		RLE Lossless 1.2.840.10008.1.2.5	O	O	O
		JPEG Lossless 1.2.840.10008.1.2.90	O	O	O
		JPEG Lossy 1.2.840.10008.1.2.91	O	O	O
Digital Intra-Oral X-Ray Image - For Processing	1.2.840.10008.5.1.4.1.1.1.3.1	Explicit VR Little Endian Uncompressed 1.2.840.10008.1.2.1	M	M	O
		JPEG Lossless Process 14 (selection value 1)	O	M	O

		1.2.840.10008.1.2.4.70			
		Explicit VR Big Endian Uncompressed 1.2.840.10008.1.2.2	O	M	O
		JPEG Lossy (baseline or extended) 1.2.840.10008.1.2.4.50 1.2.840.10008.1.2.4.51	O	O	O
		RLE Lossless 1.2.840.10008.1.2.5	O	O	O
CT Image	1.2.840.10008.5.1.4.1.1.2	Explicit VR Little Endian Uncompressed 1.2.840.10008.1.2.1	M	M	O
		JPEG Lossless Process 14 (selection value 1) 1.2.840.10008.1.2.4.70	O	M	O
		Explicit VR Big Endian Uncompressed 1.2.840.10008.1.2.2	O	M	O
		JPEG Lossy (baseline or extended) 1.2.840.10008.1.2.4.50 1.2.840.10008.1.2.4.51	O	O	O
		RLE Lossless 1.2.840.10008.1.2.5	O	O	O
		JPEG 2000 Lossless 1.2.840.10008.1.2.90	O	O	O
		JPEG 2000 Lossy 1.2.840.10008.1.2.91	O	O	O
Enhanced CT Image	1.2.840.10008.5.1.4.1.1.2.1	Explicit VR Little Endian Uncompressed 1.2.840.10008.1.2.1	M	M	O
		JPEG Lossless Process 14 (selection value 1) 1.2.840.10008.1.2.4.70	O	M	O
		JPEG Lossless, Process 14, Non-HIER 1.2.840.10008.1.2.4.57	-	M	-
		Explicit VR Big Endian Uncompressed 1.2.840.10008.1.2.2	O	M	O
		JPEG Lossy (baseline or extended) 1.2.840.10008.1.2.4.50 1.2.840.10008.1.2.4.51	O	O	O
		RLE Lossless 1.2.840.10008.1.2.5	O	O	O
		JPEG 2000 Lossless 1.2.840.10008.1.2.4.90	O	O	O
Ultrasound Multi-frame image (retired)	1.2.840.10008.5.1.4.1.1.3	JPEG 2000 Lossy 1.2.840.10008.1.2.4.91	O	O	O
		Explicit VR Little Endian Uncompressed 1.2.840.10008.1.2.1	-	M	-
		JPEG Lossless Process 14 (selection value 1) 1.2.840.10008.1.2.4.70	-	M	-
		Explicit VR Big Endian Uncompressed	-	M	-

		1.2.840.10008.1.2.2			
		JPEG Lossy (baseline or extended) 1.2.840.10008.1.2.4.50 1.2.840.10008.1.2.4.51	-	M	-
		RLE Lossless 1.2.840.10008.1.2.5	-	M	-
		JPEG 2000 Lossless 1.2.840.10008.1.2.90	-	M	-
		JPEG 2000 Lossy 1.2.840.10008.1.2.91	-	M	-
Ultrasound Multi-frame image	1.2.840.10008.5.1.4.1.1.3.1	Explicit VR Little Endian Uncompressed 1.2.840.10008.1.2.1	M	M	O
		JPEG Lossless Process 14 (selection value 1) 1.2.840.10008.1.2.4.70	O	M	O
		Explicit VR Big Endian Uncompressed 1.2.840.10008.1.2.2	O	M	O
		JPEG Lossy (baseline or extended) 1.2.840.10008.1.2.4.50 1.2.840.10008.1.2.4.51	O	O	O
		RLE Lossless 1.2.840.10008.1.2.5	O	M	O
MR Image	1.2.840.10008.5.1.4.1.1.4	Explicit VR Little Endian Uncompressed 1.2.840.10008.1.2.1	M	M	O
		JPEG Lossless Process 14 (selection value 1) 1.2.840.10008.1.2.4.70	O	M	O
		Explicit VR Big Endian Uncompressed 1.2.840.10008.1.2.2	O	M	O
		JPEG Lossy (baseline or extended) 1.2.840.10008.1.2.4.50 1.2.840.10008.1.2.4.51	O	O	O
		RLE Lossless 1.2.840.10008.1.2.5	O	O	O
		JPEG 2000 Lossless 1.2.840.10008.1.2.90	O	O	O
		JPEG 2000 Lossy 1.2.840.10008.1.2.90	O	O	O
Enhanced MR Image	1.2.840.10008.5.1.4.1.1.4.1	Explicit VR Little Endian Uncompressed 1.2.840.10008.1.2.1	M	M	O
		JPEG Lossless Process 14 (selection value 1) 1.2.840.10008.1.2.4.70	O	M	O
		JPEG Lossless, Process 14, Non-HIER 1.2.840.10008.1.2.4.57	-	M	-
		Explicit VR Big Endian Uncompressed 1.2.840.10008.1.2.2	O	M	O
		JPEG Lossy (baseline or extended)	O	O	O

		1.2.840.10008.1.2.4.50 1.2.840.10008.1.2.4.51			
		RLE Lossless 1.2.840.10008.1.2.5	O	O	O
		JPEG 2000 Lossless 1.2.840.10008.1.2.4.90	O	O	O
		JPEG 2000 Lossy 1.2.840.10008.1.2.4.91	O	O	O
Ultrasound Image (retired)	1.2.840.10008.5.1.4.1.1.6	Explicit VR Little Endian Uncompressed 1.2.840.10008.1.2.1	-	M	-
		JPEG Lossless Process 14 (selection value 1) 1.2.840.10008.1.2.4.70	-	M	-
		Explicit VR Big Endian Uncompressed 1.2.840.10008.1.2.2	-	M	-
		JPEG Lossy (baseline or extended) 1.2.840.10008.1.2.4.50 1.2.840.10008.1.2.4.51	-	M	-
		RLE Lossless 1.2.840.10008.1.2.5	-	M	-
		JPEG 2000 Lossless 1.2.840.10008.1.2.90	-	M	-
		JPEG 2000 Lossy 1.2.840.10008.1.2.91	-	M	-
Ultrasound Image	1.2.840.10008.5.1.4.1.1.6.1	Explicit VR Little Endian Uncompressed 1.2.840.10008.1.2.1	M	M	O
		JPEG Lossless Process 14 (selection value 1) 1.2.840.10008.1.2.4.70	O	M	O
		Explicit VR Big Endian Uncompressed 1.2.840.10008.1.2.2	O	M	O
		JPEG Lossy (baseline or extended) 1.2.840.10008.1.2.4.50 1.2.840.10008.1.2.4.51	O	O	O
		RLE Lossless 1.2.840.10008.1.2.5	O	M	O
		JPEG 2000 Lossless 1.2.840.10008.1.2.90	O	M	O
		JPEG 2000 Lossy 1.2.840.10008.1.2.91	O	M	O
Secondary Capture Image	1.2.840.10008.5.1.4.1.1.7	Explicit VR Little Endian Uncompressed 1.2.840.10008.1.2.1	M	M	O
		JPEG Lossless Process 14 (selection value 1) 1.2.840.10008.1.2.4.70	O	M	O
		Explicit VR Big Endian Uncompressed 1.2.840.10008.1.2.2	O	M	O
		JPEG Lossy (baseline or extended) 1.2.840.10008.1.2.4.50 1.2.840.10008.1.2.4.51	O	O	O

		RLE Lossless 1.2.840.10008.1.2.5	O	O	O
		JPEG 2000 Lossless 1.2.840.10008.1.2.90	O	O	O
		JPEG 2000 Lossy 1.2.840.10008.1.2.91	O	O	O
Multi-frame Single Bit Secondary Capture Image	1.2.840.10008.5.1.4.1.1.7.1	Explicit VR Little Endian Uncompressed 1.2.840.10008.1.2.1	M	M	O
		JPEG Lossless Process 14 (selection value 1) 1.2.840.10008.1.2.4.70	O	M	O
		JPEG Lossless, Process 14, Non-HIER 1.2.840.10008.1.2.4.57	-	M	-
		Explicit VR Big Endian Uncompressed 1.2.840.10008.1.2.2	O	M	O
		JPEG Lossy (baseline or extended) 1.2.840.10008.1.2.4.50 1.2.840.10008.1.2.4.51	O	O	O
		RLE Lossless 1.2.840.10008.1.2.5	O	O	O
		JPEG 2000 Lossless 1.2.840.10008.1.2.4.90	O	O	O
		JPEG 2000 Lossy 1.2.840.10008.1.2.4.91	O	O	O
		Multi-frame Grayscale Byte Secondary Capture Image	1.2.840.10008.5.1.4.1.1.7.2	Explicit VR Little Endian Uncompressed 1.2.840.10008.1.2.1	M
JPEG Lossless Process 14 (selection value 1) 1.2.840.10008.1.2.4.70	O			M	O
JPEG Lossless, Process 14, Non-HIER 1.2.840.10008.1.2.4.57	-			M	-
Explicit VR Big Endian Uncompressed 1.2.840.10008.1.2.2	O			M	O
JPEG Lossy (baseline or extended) 1.2.840.10008.1.2.4.50 1.2.840.10008.1.2.4.51	O			O	O
RLE Lossless 1.2.840.10008.1.2.5	O			O	O
JPEG 2000 Lossless 1.2.840.10008.1.2.4.90	O			O	O
JPEG 2000 Lossy 1.2.840.10008.1.2.4.91	O			O	O
Multi-frame Grayscale Word Secondary Capture Image	1.2.840.10008.5.1.4.1.1.7.3	Explicit VR Little Endian Uncompressed 1.2.840.10008.1.2.1	M	M	O
		JPEG Lossless Process 14 (selection value 1) 1.2.840.10008.1.2.4.70	O	M	O
		JPEG Lossless, Process 14, Non-HIER 1.2.840.10008.1.2.4.57	-	M	-

		Explicit VR Big Endian Uncompressed 1.2.840.10008.1.2.2	O	M	O
		JPEG Lossy (baseline or extended) 1.2.840.10008.1.2.4.50 1.2.840.10008.1.2.4.51	O	O	O
		RLE Lossless 1.2.840.10008.1.2.5	O	O	O
		JPEG 2000 Lossless 1.2.840.10008.1.2.4.90	O	O	O
		JPEG 2000 Lossy 1.2.840.10008.1.2.4.91	O	O	O
Multi-frame True Color Secondary Capture Image	1.2.840.10008.5.1.4.1.1.7.4	Explicit VR Little Endian Uncompressed 1.2.840.10008.1.2.1	M	M	O
		JPEG Lossless Process 14 (selection value 1) 1.2.840.10008.1.2.4.70	O	M	O
		JPEG Lossless, Process 14, Non-HIER 1.2.840.10008.1.2.4.57	-	M	-
		Explicit VR Big Endian Uncompressed 1.2.840.10008.1.2.2	O	M	O
		JPEG Lossy (baseline or extended) 1.2.840.10008.1.2.4.50 1.2.840.10008.1.2.4.51	O	O	O
		RLE Lossless 1.2.840.10008.1.2.5	O	O	O
		JPEG 2000 Lossless 1.2.840.10008.1.2.4.90	O	O	O
		JPEG 2000 Lossy 1.2.840.10008.1.2.4.91	O	O	O
12-Lead ECG	1.2.840.10008.5.1.4.1.1.9.1.1	Explicit VR Little Endian Uncompressed 1.2.840.10008.1.2.1	M	M	O
		Explicit VR Big Endian Uncompressed 1.2.840.10008.1.2.2	O	M	O
General ECG	1.2.840.10008.5.1.4.1.1.9.1.2	Explicit VR Little Endian Uncompressed 1.2.840.10008.1.2.1	M	M	O
		Explicit VR Big Endian Uncompressed 1.2.840.10008.1.2.2	O	M	O
Ambulatory ECG	1.2.840.10008.5.1.4.1.1.9.1.3	Explicit VR Little Endian Uncompressed 1.2.840.10008.1.2.1	M	M	O
		Explicit VR Big Endian Uncompressed 1.2.840.10008.1.2.2	O	M	O

Hemodynamic Waveform	1.2.840.10008.5.1.4.1.1.9.2.1	Explicit VR Little Endian Uncompressed 1.2.840.10008.1.2.1	M	M	O
		Explicit VR Big Endian Uncompressed 1.2.840.10008.1.2.2	O	M	O
Basic Cardiac Electrophysiology Waveform	1.2.840.10008.5.1.4.1.1.9.3.1	Explicit VR Little Endian Uncompressed 1.2.840.10008.1.2.1	M	M	O
		Explicit VR Big Endian Uncompressed 1.2.840.10008.1.2.2	O	M	O
Basic Voice Audio Waveform	1.2.840.10008.5.1.4.1.1.9.4.1	Explicit VR Little Endian Uncompressed 1.2.840.10008.1.2.1	M	M	O
		Explicit VR Big Endian Uncompressed 1.2.840.10008.1.2.2	O	M	O
X-Ray Angiographic Image	1.2.840.10008.5.1.4.1.1.12.1	Explicit VR Little Endian Uncompressed 1.2.840.10008.1.2.1	M	M	O
		JPEG Lossless Process 14 (selection value 1) 1.2.840.10008.1.2.4.70	O	M	O
		Explicit VR Big Endian Uncompressed 1.2.840.10008.1.2.2	O	M	O
		JPEG Lossy (baseline or extended) 1.2.840.10008.1.2.4.50 1.2.840.10008.1.2.4.51	O	O	O
		RLE Lossless 1.2.840.10008.1.2.5	O	M	O
		JPEG 2000 Lossless 1.2.840.10008.1.2.90	O	M	O
		JPEG 2000 Lossy 1.2.840.10008.1.2.91	O	M	O
X-Ray Radio-fluoroscopic Image	1.2.840.10008.5.1.4.1.1.12.2	Explicit VR Little Endian Uncompressed 1.2.840.10008.1.2.1	M	M	O
		JPEG Lossless Process 14 (selection value 1) 1.2.840.10008.1.2.4.70	O	M	O
		Explicit VR Big Endian Uncompressed 1.2.840.10008.1.2.2	O	M	O
		JPEG Lossy (baseline or extended) 1.2.840.10008.1.2.4.50 1.2.840.10008.1.2.4.51	O	O	O
		RLE Lossless 1.2.840.10008.1.2.5	O	M	O
		JPEG 2000 Lossless 1.2.840.10008.1.2.90	O	M	O
		JPEG 2000 Lossless	O	M	O

		1.2.840.10008.1.2.91			
Nuclear Medicine Image	1.2.840.10008.5.1.4.1.1.20	Explicit VR Little Endian Uncompressed 1.2.840.10008.1.2.1	M	M	O
		JPEG Lossless Process 14 (selection value 1) 1.2.840.10008.1.2.4.70	O	M	O
		Explicit VR Big Endian Uncompressed 1.2.840.10008.1.2.2	O	M	O
		JPEG Lossy (baseline or extended) 1.2.840.10008.1.2.4.50 1.2.840.10008.1.2.4.51	O	O	O
		RLE Lossless 1.2.840.10008.1.2.5	O	O	O
		JPEG 2000 Lossless 1.2.840.10008.1.2.90	O	O	O
		JPEG 2000 Lossless 1.2.840.10008.1.2.91	O	O	O
Spatial Registration	1.2.840.10008.5.1.4.1.1.66.1	Explicit VR Little Endian Uncompressed 1.2.840.10008.1.2.1	M	M	O
		Explicit VR Big Endian Uncompressed 1.2.840.10008.1.2.2	O	M	O
Spatial Fiducials	1.2.840.10008.5.1.4.1.1.66.2	Explicit VR Little Endian Uncompressed 1.2.840.10008.1.2.1	M	M	O
		Explicit VR Big Endian Uncompressed 1.2.840.10008.1.2.2	O	M	O
Basic Text SR	1.2.840.10008.5.1.4.1.1.88.11	Explicit VR Little Endian Uncompressed 1.2.840.10008.1.2.1	M	M	O
		Explicit VR Big Endian Uncompressed 1.2.840.10008.1.2.2	O	M	O
Enhanced SR	1.2.840.10008.5.1.4.1.1.88.22	Explicit VR Little Endian Uncompressed 1.2.840.10008.1.2.1	M	M	O
		Explicit VR Big Endian Uncompressed 1.2.840.10008.1.2.2	O	M	O
Comprehensive SR	1.2.840.10008.5.1.4.1.1.88.33	Explicit VR Little Endian Uncompressed 1.2.840.10008.1.2.1	M	M	O
		Explicit VR Big Endian Uncompressed 1.2.840.10008.1.2.2	O	M	O
Mammography CAD SR	1.2.840.10008.5.1.4.1.1.88.50	Explicit VR Little Endian Uncompressed 1.2.840.10008.1.2.1	M	M	O
		Explicit VR Big Endian Uncompressed 1.2.840.10008.1.2.2	O	M	O
Key Object Selection Document	1.2.840.10008.5.1.4.1.1.88.59	Explicit VR Little Endian Uncompressed 1.2.840.10008.1.2.1	M	M	O

		Explicit VR Big Endian Uncompressed 1.2.840.10008.1.2.2	O	M	O
Chest CAD SR	1.2.840.10008.5.1.4.1.1.88.65	Explicit VR Little Endian Uncompressed 1.2.840.10008.1.2.1	M	M	O
		Explicit VR Big Endian Uncompressed 1.2.840.10008.1.2.2	O	M	O
X-Ray Radiation Dose SR	1.2.840.10008.5.1.4.1.1.88.67	Explicit VR Little Endian Uncompressed 1.2.840.10008.1.2.1	M	M	O
		Explicit VR Big Endian Uncompressed 1.2.840.10008.1.2.2	O	M	O
Positron Emission Tomography Image	1.2.840.10008.5.1.4.1.1.128	Explicit VR Little Endian Uncompressed 1.2.840.10008.1.2.1	M	M	O
		JPEG Lossless Process 14 (selection value 1) 1.2.840.10008.1.2.4.70	O	M	O
		Explicit VR Big Endian Uncompressed 1.2.840.10008.1.2.2	O	M	O
		JPEG Lossy (baseline or extended) 1.2.840.10008.1.2.4.50 1.2.840.10008.1.2.4.51	O	O	O
		RLE Lossless 1.2.840.10008.1.2.5	O	O	O
		JPEG 2000 Lossless 1.2.840.10008.1.2.90	O	O	O
		JPEG 2000 Lossy 1.2.840.10008.1.2.91	O	O	O
RT Image	1.2.840.10008.5.1.4.1.1.481.1	Explicit VR Little Endian Uncompressed 1.2.840.10008.1.2.1	M	M	O
		JPEG Lossless Process 14 (selection value 1) 1.2.840.10008.1.2.4.70	O	M	O
		Explicit VR Big Endian Uncompressed 1.2.840.10008.1.2.2	O	M	O
		JPEG Lossy (baseline or extended) 1.2.840.10008.1.2.4.50 1.2.840.10008.1.2.4.51	O	O	O
		RLE Lossless 1.2.840.10008.1.2.5	O	O	O
		JPEG 2000 Lossless 1.2.840.10008.1.2.90	O	O	O
		JPEG 2000 Lossy 1.2.840.10008.1.2.91	O	O	O
RT Dose	1.2.840.10008.5.1.4.1.1.481.2	Explicit VR Little Endian Uncompressed 1.2.840.10008.1.2.1	M	M	O
		Explicit VR Big Endian Uncompressed	O	M	O

		1.2.840.10008.1.2.2			
RT Structure Set	1.2.840.10008.5.1.4.1.1.481.3	Explicit VR Little Endian Uncompressed 1.2.840.10008.1.2.1	M	M	O
		Explicit VR Big Endian Uncompressed 1.2.840.10008.1.2.2	O	M	O
RT Beams Treatment Record	1.2.840.10008.5.1.4.1.1.481.4	Explicit VR Little Endian Uncompressed 1.2.840.10008.1.2.1	M	M	O
		Explicit VR Big Endian Uncompressed 1.2.840.10008.1.2.2	O	M	O
RT Plan	1.2.840.10008.5.1.4.1.1.481.5	Explicit VR Little Endian Uncompressed 1.2.840.10008.1.2.1	M	M	O
		Explicit VR Big Endian Uncompressed 1.2.840.10008.1.2.2	O	M	O
RT Brachy Treatment Record	1.2.840.10008.5.1.4.1.1.481.6	Explicit VR Little Endian Uncompressed 1.2.840.10008.1.2.1	M	M	O
		Explicit VR Big Endian Uncompressed 1.2.840.10008.1.2.2	O	M	O
RT Treatment Summary Record	1.2.840.10008.5.1.4.1.1.481.7	Explicit VR Little Endian Uncompressed 1.2.840.10008.1.2.1	M	M	O
		Explicit VR Big Endian Uncompressed 1.2.840.10008.1.2.2	O	M	O
RT Ion Plan	1.2.840.10008.5.1.4.1.1.481.8	Explicit VR Little Endian Uncompressed 1.2.840.10008.1.2.1	M	M	O
		Explicit VR Big Endian Uncompressed 1.2.840.10008.1.2.2	O	M	O
RT Ion Beams Treatment Record	1.2.840.10008.5.1.4.1.1.481.9	Explicit VR Little Endian Uncompressed 1.2.840.10008.1.2.1	M	M	O
		Explicit VR Big Endian Uncompressed 1.2.840.10008.1.2.2	O	M	O
CSA Non-Image	1.3.12.2.1107.5.9.1	Explicit VR Little Endian Uncompressed 1.2.840.10008.1.2.1	O	M	O

FSC, FSR, FSU - denote the requirement for those roles

O - Optional
M - Mandatory

5.3.2.3.2 Physical Media Formats

The PRI-SYNGO-CD Profile requires the 120mm CD-R physical media with the ISO/IEC 9660 Media Format, as defined in PS3.12.

The PRI-SYNGO-DVD Profile requires the 120mm DVD-R physical media with the UDF 2.01 Media Format, as defined in PS3.12.

The PRI-SYNGO-USB Profile requires the USB of any size. There is no application implemented size limit to the USB device. MS Windows supported file systems can be used (FAT32, exFAT, NTFS). A (pre-)formatted medium is required.

5.3.2.3.3 Directory Information in DICOMDIR

Conforming Application Entities shall include in the DICOMDIR File the Basic Directory IOD containing Directory Records at the Patient and subsidiary levels appropriate to the SOP Classes in the File Set. All DICOM files in the File Set incorporating SOP instances defined for the specific Application Profile shall be referenced by Directory Records.

Note:

DICOMDIRs with no directory information are not allowed by this Application Profile.

Privately defined IODs will be referenced by "PRIVATE" Directory Records.

5.3.2.3.3.1 Basic Directory IOD Specification

This Application Profile makes use of optional attributes of the Basic Directory IOD to support recognition of Patient’s Storage Service request results in spanning multiple volumes (file sets). Therefore, the File Set Descriptor File can be used and is then referenced by optional Basic Directory IOD attributes. If existent, the specified Descriptor File may be used by FSR applications. Any FSU, FSC shall make a clear statement if the Descriptor File mechanism is used according to the specialization defined in this Application Profile.

The Descriptor Files shall have the following contents:

One single line without any control characters and according to the Basic Character Set having the following defined text:

"MULTIVOLUME: xx of yy"

xx, yy are replaced by the actual number of the volume (xx) and the total number of volumes in the set (yy).

If used, the Descriptor File shall have the File ID "README" and reside in the same directory level as the DICOMDIR. It is referenced by the attribute [0004,1141] File Set Descriptor File ID having the defined contents of "README".

5.3.2.3.3.2 Additional Keys

File Set Creators and Updaters are required to generate the mandatory elements specified in PS 3.3, Annex F of the DICOM Standard. Table below: PRI-SYNGO-CD Additional DICOMDIR Keys specifies the additional associated keys. At each directory record level other additional data elements can be added, but it is not required that File Set Readers be able to use them as keys. Refer to the Basic Directory IOD in PS 3.3.

Table 68: DICOMDIR keys

Attribute Name	Tag	Directory Record Level	Type	Notes
Patient’s Birth Date	(0010,0030)	PATIENT	2C	required, if present in SOP Instance
Patient’s Sex	(0010,0040)	PATIENT	2C	required, if present in SOP Instance
Series Date	(0008,0021)	SERIES	3	
Series Time	(0008,0031)	SERIES	3	
Institution Name	(0008,0080)	SERIES	2C	required, if present in SOP Instance
Institution Address	(0008,0081)	SERIES	2C	required, if present in SOP Instance
Series Description	(0008,103E)	SERIES	3	
Performing Physician’s Name	(0008,1050)	SERIES	2C	required, if present in SOP Instance
Image Type	(0008,0008)	IMAGE	1C	required, if present in SOP Instance
SOP Class UID	(0008,0016)	IMAGE	3	

SOP Instance UID	(0008,0018)	IMAGE	3	
Content Date	(0008,0023)	IMAGE	3	
Content Time	(0008,0033)	IMAGE	3	
Referenced Image Sequence	(0008,1140)	IMAGE	1C	required, if present in SOP Instance
> Referenced SOP Class UID	(0008,1150)			
> Referenced SOP Instance UID	(0008,1155)			
Image Position (Patient)	(0020,0032)	IMAGE	2C	required, if present in SOP Instance
Image Orientation (Patient)	(0020,0037)	IMAGE	2C	required, if present in SOP Instance
Frame of Reference UID	(0020,0052)	IMAGE	2C	required, if present in SOP Instance
Rows	(0028,0010)	IMAGE	3	
Columns	(0028,0011)	IMAGE	3	
Pixel Spacing	(0028,0030)	IMAGE	1C	C
Calibration Image	(0050,0004)	IMAGE	2C	required, if present in SOP Instance
Icon Image Sequence	(0088,0200)	IMAGE	3	required for Image SOP Classes
> Samples per Pixel	(0028,0002)			1
> Photometric Interpretation	(0028,0004)			MONOCHROME2
> Rows	(0028,0010)			128 for XA IOD, 64 otherwise
> Columns	(0028,0011)			128 for XA IOD, 64 otherwise
> Bits Allocated	(0028,0100)			8
> Bits Stored	(0028,0101)			8
> High Bit	(0028,0102)			7
> Pixel Representation	(0028,0103)			0 (unsigned)
> Pixel Data	(7FE0,0010)			Icon Image pixel data
Curve Number	(0020,0024)	CURVE	1C	required, if present in SOP Instance

Private Directory Records are supported by this Application Profile Class at the following level: IMAGE

The PRIVATE Directory Records will have required elements in addition to the mandatory elements specified in PS 3.3.

The following table will list the additional required keys for PRIVATE Directory Records.

Table 69: DICOMDIR keys for CSA Non-Image

Attribute Name	Tag	Directory Record Level	Type	Notes
Private Record UID	(0004,1432)	PRIVATE	1	See Table 192Table 192: Extensions to the Basic Directory for Siemens Non-Image Objects
SOP Class UID	(0008,0016)	PRIVATE	1C	required, if present in SOP Instance

SOP Instance UID	(0008,0018)	PRIVATE	1C	required, if present in SOP Instance
Image Type	(0008,0008)	PRIVATE	3	identification characteristics
Acquisition Date	(0008,0022)	PRIVATE	3	
Acquisition Time	(0008,0032)	PRIVATE	3	
Acquisition Number	(0020,0012)	PRIVATE	3	
CSA Data Type	(0029,xx08)	PRIVATE	1	Private Creator Identifier = SIEMENS CSA NON-IMAGE
CSA Data Version	(0029,xx09)	PRIVATE	3	Private Creator Identifier = SIEMENS CSA NON-IMAGE

5.3.2.3.3 *Icon Image Sequence*

Directory Records of type SERIES or IMAGE may include Icon Images. The Icon Image Pixel data shall be as specified in PS 3.3 "Icon Image Key Definition", and restricted such, that Bits Allocated (0028,0100) and Bits Stored (0028,0101) shall be equal to 8, and Rows (0028,0010) and Columns (0028, 0011) shall be equal to 128 for XA Images and 64 for all other images. The Photometric interpretation (0028,0004) shall always be restricted to "MONOCHROME2".

PRIVATE Directory Records will not contain Icon Image information.

5.3.2.3.4 **Other Parameters**

This section defines other parameters common to all specific Application Profiles in the PRI-SYNGO class which need to be specified in order to ensure interoperable media interchange.

5.3.2.3.4.1 *Multiframe JPEG Format*

The JPEG encoding of pixel data shall use Interchange Format (with table specification) for all frames

5.4 **Media Configuration**

5.4.1 **Auto-Labeling**

Please refer to most recent Service / Configuration documentation of Biograph Vision for activating the auto-labeling of CD/DVD media to avoid the label inquiry dialog when using automatic media export. The auto-labeling can be activated with the "Viewer on CD" feature being implicitly checked or not.

5.4.2 **Compression**

Please refer to most recent Instruction for User documentation of Biograph Vision for activating the permitted Transfer Syntax of images written to CD/DVD/USB media. It is possible to configure uncompressed / lossless compressed / lossy compressed range of Transfer Syntaxes. JPEG 2000 based compression is not supported for export to media (FSC/FSU), as documented earlier.

If lossy compression is configured, a quality factor must be provided. A value in the range from 1 to 99 is possible.

5.4.3 **Private SOP Class export**

Implicit export of Private SOP Class CSA Non-Image can be activated or deactivated. Default is Deactivated. This will support to generate media conforming to Augmented Application Profiles instead of Private Application Profiles, unless objects of Private SOP Class are really wanted on the medium.

5.4.4 Browser support for USB device

It is only when Browser support is configured for external USB device that it is processed as a DICOM medium and available in Browser UI. Otherwise, it is just an offline file storage location.

6 Transformation of DICOM to CDA

N/A

7 Support of Character Sets

The Biograph Vision DICOM application supports the following character sets as defined in the four tables below:

Table 70: Single-Byte Character Sets without Code Extension

Character Set Description	Defined Term	ISO registration number	Character Set
Default repertoire	none	ISO-IR 6	ISO 646:
Latin alphabet No. 1	ISO_IR 100	ISO-IR 100	Supplementary set
		ISO-IR 6	ISO 646:
Latin alphabet No. 2	ISO_IR 101	ISO-IR 101	Supplementary set
		ISO-IR 6	ISO 646
Latin alphabet No. 3	ISO_IR 109	ISO-IR 109	Supplementary set
		ISO-IR 6	ISO 646
Latin alphabet No. 4	ISO_IR 110	ISO-IR 110	Supplementary set
		ISO-IR 6	ISO 646
Cyrillic	ISO_IR 144	ISO-IR 144	Supplementary set
		ISO-IR 6	ISO 646
Arabic	ISO_IR 127	ISO-IR 127	Supplementary set
		ISO-IR 6	ISO 646
Greek	ISO_IR 126	ISO-IR 126	Supplementary set
		ISO-IR 6	ISO 646
Hebrew	ISO_IR 138	ISO-IR 138	Supplementary set
		ISO-IR 6	ISO 646
Latin alphabet No. 5	ISO_IR 148	ISO-IR 148	Supplementary set
		ISO-IR 6	ISO 646
Japanese	ISO_IR 13	ISO-IR 13	JIS X 0201: Katakana
		ISO-IR 14	JIS X 0201: Romaji

Table 71: Single-Byte Characters Sets with Code Extension

Character Set Description	Defined Term	Standard for Code Extension	ESC sequence	ISO registration number	Character Set
Default repertoire	ISO 2022 IR 6	ISO 2022	ESC 02/08 04/02	ISO-IR 6	ISO 646
Latin alphabet No.1	ISO 2022 IR 100	ISO 2022	ESC 02/13 04/01	ISO-IR 100	Supplementary set
		ISO 2022	ESC 02/08 04/02	ISO-IR 6	ISO 646
Latin alphabet No.2	ISO 2022 IR 101	ISO 2022	ESC 02/13 04/02	ISO-IR 101	Supplementary set
		ISO 2022	ESC 02/08 04/02	ISO-IR 6	ISO 646
Latin alphabet No.3	ISO 2022 IR 109	ISO 2022	ESC 02/13 04/03	ISO-IR 109	Supplementary set
		ISO 2022	ESC 02/08 04/02	ISO-IR 6	ISO 646
Latin alphabet No.4	ISO 2022 IR 110	ISO 2022	ESC 02/13 04/04	ISO-IR 110	Supplementary set
		ISO 2022	ESC 02/08 04/02	ISO-IR 6	ISO 646
Cyrillic	ISO 2022 IR 144	ISO 2022	ESC 02/13 04/12	ISO-IR 144	Supplementary set
		ISO 2022	ESC 02/08 04/02	ISO-IR 6	ISO 646
Arabic	ISO 2022 IR 127	ISO 2022	ESC 02/13 04/07	ISO-IR 127	Supplementary set
		ISO 2022	ESC 02/08 04/02	ISO-IR 6	ISO 646
Greek	ISO 2022 IR 126	ISO 2022	ESC 02/13 04/06	ISO-IR 126	Supplementary set
		ISO 2022	ESC 02/08 04/02	ISO-IR 6	ISO 646
Hebrew	ISO 2022 IR 138	ISO 2022	ESC 02/13 04/08	ISO-IR 138	Supplementary set
		ISO 2022	ESC 02/13 04/02	ISO-IR 6	ISO 646
Latin alphabet No. 5	ISO 2022 IR 148	ISO 2022	ESC 02/13 04/13	ISO-IR 148	Supplementary set
		ISO 2022	ESC 02/13 04/02	ISO-IR 6	ISO 646
Japanese	ISO 2022 IR 13	ISO 2022	ESC 02/13 04/09	ISO-IR 13	JIS X 0201: Katakana
		ISO 2022	ESC 02/13 04/10	ISO-IR 14	JIS X 0201-1976: Romaji

Table 72: Multi-Byte Character Set without Code Extension

Character Set Description	Defined Term	ISO registration number	Character Set
Unicode	ISO_IR 192	ISO 10646	Unicode in UTF-8
Chinese	GB18030	GB18030	GB 18030-2000 (China Association for Standardization)

Table 73: Multi-Byte Character Sets with Code Extension

Character Set Description	Defined Term	Standard for Code Extension	ESC sequence	ISO registration number	Character Set
Japanese	ISO 2022 IR 87	ISO 2022	ESC 02/04 04/02	ISO-IR 87	JIS X 0208: Kanji
	ISO 2022 IR 159	ISO 2022	ESC 02/04 02/08 04/04	ISO-IR 159	JIS X 0212: Supplementary Kanji set
Chinese ¹	ISO 2022 IR 58	ISO 2022	ESC 02/04 04/01	ISO-IR 58	GB2312-80 (China Association for Standardization)

When there is a mismatch between the Specific Character Set tag (0008,0005) and the characters in an IOD received by the system, then the following measures are taken to make the characters DICOM conform:

- Try to import with ISO_IR 100. If ISO_IR 100 fails, convert each illegal character to a '?'.¹

There are now three categories of character sets which have to be differentiated because of their different encoding formats:

- Conventional ISO character sets: ISO_IR 6, ISO 2022 IR 6, ISO_IR 100, etc., encoded in ISO 2022
- ISO_IR 192 encoded in UTF-8
- GB18030 encoded in GB18030

It is not possible to recognize the following mismatches automatically on receiving or importing:

- An attribute value is encoded in ISO_IR 192 ↔ (0008,0005) contains a conventional ISO character set as primary character set
- An attribute value is encoded in GB18030 ↔ (0008,0005) contains a conventional ISO character set as primary character set
- An attribute value is encoded in ISO 2022 ↔ (0008,0005) contains ISO_IR 192
- An attribute value is encoded in ISO 2022 ↔ (0008,0005) contains GB18030

An IOD that contains one of the above-mentioned inconsistencies is not DICOM conformant. As these kinds of inconsistencies cannot be recognized by the system, the IOD will not be rejected but the character data might be corrupted.

Configuration of Character Sets to be used for creation of IODs is possible as a default for local patient registration. Modality Worklist can send a different Character Set for an entry, this will override configured value.

¹ This Character Set is an extension of DICOM for the Chinese language.

Character Sets are not mapped to others or converted after initial definition, e.g. on registration or after receiving DICOM data. Only in case character set with code extension is initially defined, extensions are possible.
Presentation of characters to the user is widely based on MS Windows capability to display the character.

8 Security

Biograph Vision conforms to the IHE Basic Security Integration Profile that is used for the DICOM Communication. Biograph Vision allows the use of either a conventional (non-secure) DICOM communication or a secure DICOM communication.

For secure DICOM communication Biograph Vision application uses Transport Layer Protocol (Protocol version TLS v1.2 is enabled by default and the protocol versions TLS Protocol v1.1 and TLS v1.0 are disabled by default). Following features are supported for the secure DICOM communication. The port in which Biograph Vision act as SCP for secure DICOM communication is 2762 (fixed). The port in which Biograph Vision act as SCP for unsecure DICOM communication is 104 (fixed). By default, unsecure mode is not available.

The following security profile are done in Biograph Vision using TLS protocols

- Secure authentication of node
- Integrity and confidentiality of transmitted data.
- Generation of audit trail records access control and user authentication.

8.1 Security Profiles

Biograph Vision conforms to the Basic TLS Secure Transport Connection Profile even though the Basic TLS Secure Transport Connection Profile has been retired by DICOM.

The software initiates the TLS connections and accepts TLS connections with Storage commitment. Biograph Vision provides a configuration panel by which local systems can configure the certificate that needs to bind for DICOM communication. Secure communication is a “mode of operation” of Biograph Vision supported by the implementation of the DICOM Basic TLS Secure Transport Connection Profile. This functionality will be used by the nodes that can authenticate each other before they exchange DICOM information. For secure communication the TLS protocol is used which provides message authentication, integrity and confidentiality. Biograph Vision supports TLS Protocol v1.2 by default and TLS Protocol v1.1 and TLS Protocol v1.0 are disabled by default. By enabling the service configuration disabled protocols TLS Protocol v1.1 and TLS Protocol v1.0 are enabled and used for secure DICOM communication.

Biograph Vision supports X.509 certificates. The type of X.509 certificates that are supported in Biograph Vision are

- 1) Self-Signed certificate
- 2) Certificate for which chain building (Trusted chain building, Trusted CA) is possible.

The following TLS certification checks will be done (TLS Handshake). The machine (either server or client) that will send its certificate will:

- Choose the certificate according to Common Name (CN), if the Biograph Vision self-signed is used. If customer specific certificate needs to be used, then Serial Number of the certificate is used for choosing the certificate.

The server verifies

- that the client certificate is X.509 certificate which is not tampered with
- that the client certificate is in the list of trusted certificates (Trust Chain Building)
- that the client certificate is not in the revoked list.
- that the client certificate is not expired (present time is between “Valid From” and “Valid To” fields of X.509 certificate)
- that the client certificate has the correct purpose (at least the client authentication purpose).

The client verifies

- that the server certificate is a X.509 certificate which is not tampered with
- that the server certificate is in the list of trusted certificates (Trust Chain Building)
- that the server certificate is not in the revoked list.
- that the server certificate is not expired (present time is between “Valid From” and “Valid To” fields of X.509 certificate)
- that the server certificate has the correct purpose (at least the server authentication purpose).

In addition, the following validation is done at Biograph Vision side

- 1) 'Direct certificate validation' for self-signed certificate, i.e., the self-signed certificate of the remote node must be present in the 'Trusted Root Certificate' Store Certificate received from peer have multiple X.509 certificates within the TLS Handshake.
- 2) Biograph Vision can receive X.509 certificate chain (Full certificate chain, Partial certificate chain or only End certificate) in the TLS handshake from peer. For all the cases for successful Trust chain Building all the certificates shall be installed in the Windows certificate Store of the Local Machine. i.e., All the intermediates must be imported to Intermediate Certificate Authorities→Certificates and the root certificate must be imported to the Trusted Root Certificates→Certificates.

The X.509 certificate imported and used for DICOM communication

1. must have purpose set for Client and Server Authentication.
2. must be exportable to generate the certificate file and private key file.

If intermediate and root X.509 certificates are present, then the intermediate certificate must be imported to Intermediate Certificate Authorities→Certificates. The root certificate must be imported to the Trusted Root Certificates→Certificates.

By default, Biograph Vision communicates with the cipher suites defined by Windows. By default, with the Biograph Vision installations following SCHANNEL registries are set with the following values. Based on these values the Biograph Vision supported suites are decided.

CIPHERS REGISTRIES

HKLM\SYSTEM\CurrentControlSet\Control\SecurityProviders\SCHANNEL\Ciphers\triple DES 168\Enabled with value 0x0

HKLM\SYSTEM\CurrentControlSet\Control\SecurityProviders\SCHANNEL\Ciphers\AES 128\Enabled with value 0xFFFFFFFF

HKLM\SYSTEM\CurrentControlSet\Control\SecurityProviders\SCHANNEL\Ciphers\AES 256\Enabled with value 0xFFFFFFFF

HASHES REGISTRIES

HKLM\SYSTEM\CurrentControlSet\Control\SecurityProviders\SCHANNEL\Hashes\SHA\Enabled with value 0x0a

HKLM\SYSTEM\CurrentControlSet\Control\SecurityProviders\SCHANNEL\Hashes\SHA256\Enabled with value 0xFFFFFFFF

HKLM\SYSTEM\CurrentControlSet\Control\SecurityProviders\SCHANNEL\Hashes\SHA384\Enabled with value 0xFFFFFFFF

KEY EXCHANGE ALGORITHM

HKLM\SYSTEM\CurrentControlSet\Control\SecurityProviders\SCHANNEL\KeyExchangeAlgorithms\PKCS\Enabled with value 0x0

HKLM\SYSTEM\CurrentControlSet\Control\SecurityProviders\SCHANNEL\KeyExchangeAlgorithms\Diffie-Hellman\Enabled with value 0xFFFFFFFF

HKLM\SYSTEM\CurrentControlSet\Control\SecurityProviders\SCHANNEL\KeyExchangeAlgorithms\ECDH\Enabled with value 0xFFFFFFFF

In addition, the PROTOCOLS registries entries are set with the following values with Biograph Vision installation.

HKEY_LOCAL_MACHINE\SYSTEM\CurrentControlSet\Control\SecurityProviders\SCHANNEL\Protocols\TLS 1.0\Client\Enabled 0x0 (Biograph Vision acting as SCU)

HKEY_LOCAL_MACHINE\SYSTEM\CurrentControlSet\Control\SecurityProviders\SCHANNEL\Protocols\TLS 1.0\Server\Enabled 0x0 (Biograph Vision acting as SCP)

HKEY_LOCAL_MACHINE\SYSTEM\CurrentControlSet\Control\SecurityProviders\SCHANNEL\Protocols\TLS 1.1\Client\Enabled 0x0 (Biograph Vision acting as SCU)

HKEY_LOCAL_MACHINE\SYSTEM\CurrentControlSet\Control\SecurityProviders\SCHANNEL\Protocols\TLS 1.1\Server\Enabled 0x0 (Biograph Vision acting as SCP)

HKEY_LOCAL_MACHINE\SYSTEM\CurrentControlSet\Control\SecurityProviders\SCHANNEL\Protocols\TLS 1.2\Client\Enabled 0xFFFFFFFF (Biograph Vision acting as SCU)

HKEY_LOCAL_MACHINE\SYSTEM\CurrentControlSet\Control\SecurityProviders\SCHANNEL\Protocols\TLS 1.2\Server\Enabled 0xFFFFFFFF (Biograph Vision acting as SCP)

NOTE:

- 1) For disabling the weaker ciphers, Hashes, Key exchange algorithms and protocols the registry entry 'Enabled' for the corresponding ciphers, Hashes, Key exchange algorithms and protocols in windows SCHANNEL (HKEY_LOCAL_MACHINE\SYSTEM\CurrentControlSet\Control\SecurityProviders\SCHANNEL) must be set as 0x0. The value other than 0xffffffff / 0xFFFFFFFF for 'Enabled' registry will be considered as Disabled.
- 2) In addition, for disabling Protocols TLS v1.0, TLS v1.1 and TLS v1.2 TLS the Windows SCHANNEL registry 'DisabledbyDefault' for the protocol registry entry must be set to 0x00000001. If this registry is set to 0x0 then it is considered as enabled.
- 3) The Ciphers (Triple DES, AES 128 and AES 256), Hashes (SHA, SHA 256, SHA 384), Key Exchange algorithms (PKCS, Diffie-Hellman, ECDH) and Protocols (TLS v1.2, TLS v1.1 and TLS v1.0) are proposed for DICOM secure communication based on the configuration. The other protocols, Hashes, Key Exchange algorithms and ciphers are not checked and proposed.

With the Biograph Vision installation, the weaker cipher suites which are supported earlier will not be supported. i.e. the cipher suites TLS_RSA_WITH_AES_128_CBC_SHA and TLS_RSA_WITH_3DES_EDE_CBC_SHA. This will have an interoperability issue to older Biograph Vision systems / systems that is using these cipher suites only. In order to overcome this interoperability issue a single configuration is provided in the service page to enable/disable the Hashes, Ciphers, Key Exchange algorithms and Protocols.

- 4) Support for NULL Cipher (TLS_RSA_WITH_NULL_SHA) is not there. The secure communication is FIPS mode enabled

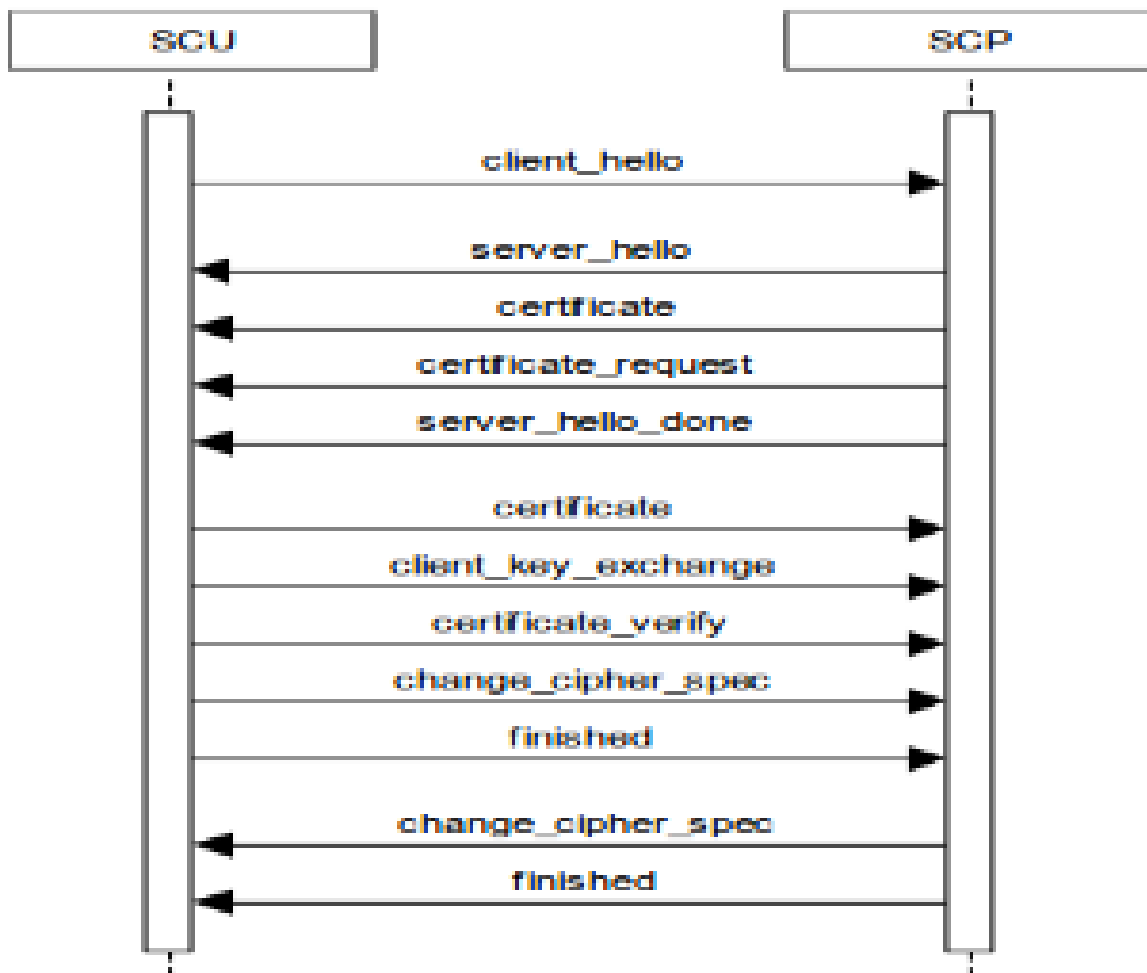

Figure 9: TLS Handshake Message Protocol

8.2 Association Level Security

It is possible to configure whether the SCP will only answer to known AETs or to any AET.

8.3 Application-Level Security

- User must login with own password
- For configuration and Maintenance, Service Technician must login with a separate password.

8.4 Media storage attribute confidentiality

8.4.1 De-identification

Biograph Vision provides a functionality to export the DICOM data to configured offline directories (Local Path / Network path / USB). The minimized data can be exported where the Patient Identification parameters like Patient's Name, Patient ID etc., are removed or replaced as per the Table below.

Table 74: DICOM Attributes behavior in case of export to offline with option "Personal identifier minimized"

Attribute Name	DICOM Tag	VR	Type	Value
Patient's Name	(0010,0010)	PN	2	Dummy Name – User specific
Patient ID	(0010,0020)	LO	2	"Anonymous" – Hard coded value
Patient's Birth Date	(0010,0030)	DA	2	empty
Patient's Birth Time	(0010,0032)	TM	3	removed
Patient's Sex	(0010,0040)	CS	2	Other (O)
Other Patient IDs	(0010,1000)	LO	3	removed
Other Patient Names	(0010,1001)	PN	3	removed
Patient's Birth Name	(0010,1005)	PN	3	removed
Patient's Address	(0010,1040)	LO	3	removed
Patient's Mother's Birth Name	(0010,1060)	PN	3	removed
Patient's Telephone Numbers	(0010,2154)	SH	3	removed
SOP Instance UID	(0008,0018)	UI	1	new value to be generated
Referenced Patient Sequence	(0008,1120)	SQ	3	removed
Instance Creator UID	(0008,0014)	UI	3	removed
Accession Number	(0008,0050)	SH	2	empty
Institution Name	(0008,0080)	LO	3	removed
Institution Address	(0008,0081)	ST	3	removed
Referring Physician's Name	(0008,0090)	PN	2	empty
Referring Physician's Address	(0008,0092)	ST	3	removed
Referring Physician's Telephone Numbers	(0008,0094)	SH	3	removed

Attribute Name	DICOM Tag	VR	Type	Value
Station Name	(0008,1010)	SH	3	removed
Study Description	(0008,1030)	LO	3	removed
Series Description	(0008,103E)	LO	3	removed
Institutional Department Name	(0008,1040)	LO	3	removed
Physician(s) of Record	(0008,1048)	PN	3	removed
Performing Physician(s) Name	(0008,1050)	PN	3	removed
Name of Physician(s) Reading Study	(0008,1060)	PN	3	removed
Operators' Name	(0008,1070)	PM	3	removed
Admitting Diagnoses Description	(0008,1080)	LO	3	removed
Referenced SOP Instance UID	(0008,1155)	UI	1C	new value to be generated
Related Series Sequence	(0008,1250)	SQ	3	new value to be generated
Derivation Description	(0008,2111)	ST	3	new value to be generated
Patient's Age	(0010,1010)	AS	3	removed
Patient's Size	(0010,1020)	DS	3	removed
Patient's Weight	(0010,1030)	DS	3	removed
Medical Record Locator	(0010,1090)	LO	3	removed
Ethnic Group	(0010,2160)	SH	3	removed
Occupation	(0010,2180)	SH	3	removed
Additional Patient's History	(0010,21B0)	LT	3	removed
Patient Comments	(0010,4000)	LT	3	removed
Device Serial Number	(0018,1000)	LO	3	removed
Protocol Name	(0018,1030)	LO	3	removed
Study Instance UID	(0020,000D)	UI	1	new value to be generated
Series Instance UID	(0020,000E)	UI	1	new value to be generated
Study ID	(0020,0010)	SH	2	empty
Frame of Reference UID	(0020,0052)	UI	1	new value to be generated
Synchronization Frame of Reference UID	(0020,0200)	UI	1	new value to be generated
Image Comments	(0020,4000)	LT	3	removed

Attribute Name	DICOM Tag	VR	Type	Value
Request Attribute Sequence	(0040,0275)	SQ	3	removed
UID	(0040, A124)	UI	1c	new value to be generated
Content Sequence	(0040, A730)	SQ	1c	new value to be generated
Storage Media File-set UID	(0088,0140)	UI	1	new value to be generated
Referenced Frame of Reference UID	(3006,0024)	UI	1c	new value to be generated
Related Frame of Referenced UID	(3006,00C2)	UI	1c	new value to be generated
3D registration Matrix Data Info	(0029, 1010)	OB	n/a	XML file contents (UID value referred needs to be updated with new value)

syngo provides two type of data minimization: Default profile and Service profile. A modality registry configuration 'DISABLE_OFFLINE_SERVICE_ANONYMIZATION' is provided to select the type of data minimization. The Biograph Vision application sets the value of the registry to 1 and hence Default profile is used.

In Default profile, the data integrity and consistency are maintained for the new value generated for the DICOM attribute of VR type UI. i.e., For example, if the new value is set for the Study Instance UID and if the value is referred in Frame of Reference UID the value must be reused. This ensures the consistency of the data. (With Service profile, the data integrity would not be maintained.)

9 Annexes

9.1 IOD Contents

9.1.1 Created SOP Instance(s)

The following SOP instances are created by Biograph Vision (details regarding each are in the sections below):

- 9.1.1.2 CT Image IOD
- 9.1.1.3 Secondary Capture Image IOD
- 9.1.1.4 X-Ray Radiation Dose SR IOD
- 9.1.1.5 Radiopharmaceutical Radiation Dose SR IOD
- 9.1.1.6 Comprehensive SR IOD
- 9.1.1.7 CSA Non-Image IOD
- 9.1.1.8 Positron Emission Tomography Image IOD
- 9.1.1.9 Encapsulated PDF IOD

Throughout the following sections, the tables use a number of abbreviations. The abbreviations used in the “Presence” column are

- VNAP: Value is Not Always Present. Attribute is sent zero length if no value is present.
- ANAP: Attribute Not Always Present.
- ALWAYS: Attribute and Value are always present.
- EMPTY: Attribute is sent zero length.

The abbreviations used in the “Source” Column are

- MWL: The attribute value is copied from Modality Worklist.
- USER: The attribute value is entered by the user.
- AUTO: The attribute value is generated by the system.
- CONFIG: The attribute value is obtained by configuration
- MPPS: The attribute value is copied from Performed Procedure Step.

A specific additional abbreviation used in the “Module” Column of IOD Module tables is

- (P): The listed module has been defined private.

9.1.1.1 Common Modules

The following modules are common for multiple IODs. If a module does use such common module, then it will reference the following sub-chapters and tables.

9.1.1.1.1 Module Patient (Common for CT Image, SC Image, SR, CSA Non-Image)

Table 75 The table in this section lists all attributes that are supported in the Patient Module for the IODs:

- CT Image
- Secondary Capture Image
- X-Ray Radiation Dose SR
- Radiopharmaceutical Radiation Dose SR
- Comprehensive SR
- CSA Non-Image

Table 75: Patient Module Attributes

Attribute Name	Tag	VR	Source	Value	Presence	Comments
Patient's Name	(0010,0010)	PN	MWL, USER, AUTO		ALWAYS	1)
Patient ID	(0010,0020)	LO	MWL, USER, AUTO		ALWAYS	1)
Issuer of Patient ID	(0010,0021)	LO	MWL		ANAP	
Patient's Birth Date	(0010,0030)	DA	MWL, USER		VNAP	Format: YYYYMMDD
Patient's Sex	(0010,0040)	CS	MWL, USER	M,F,O	VNAP	
Referenced Patient Sequence	(0008,1120)	SQ	MWL		ANAP	
> Referenced SOP Class UID	(0008,1150)	UI	MWL		ALWAYS	
> Referenced SOP Instance UID	(0008,1155)	UI	MWL		ALWAYS	
Other Patient IDs (RETIRED)	(0010,1000)	LO	MWL		ANAP	

1) In case of "emergency patient" the attributes Patient ID and Patient Name are filled with a device generated value which contains a timestamp.

9.1.1.1.2 Module General Study (Common for CT Image, SC Image, SR, CSA Non-Image)

Table 76 The table in this section lists all attributes that are supported in the General Study Module for the IODs:

- CT Image
- Secondary Capture Image
- X-Ray Radiation Dose SR
- Radiopharmaceutical Radiation Dose SR
- Comprehensive SR
- CSA Non-Image

Table 76: General Study Module Attributes

Attribute Name	Tag	VR	Source	Value	Presence	Comments
Study Instance UID	(0020,000D)	UI	MWL, AUTO	From MWL or "1.3.12.2.1107.5.1.4." +UID	ALWAYS	
Study Date	(0008,0020)	DA	AUTO		ALWAYS	Local date when study was created
Study Time	(0008,0030)	TM	AUTO		ALWAYS	Format: hhmmss.nnnnnn
Referring Physician's Name	(0008,0090)	PN	MWL		VNAP	
Study ID	(0020,0010)	SH	MWL, AUTO		VNAP	
Accession Number	(0008,0050)	SH	MWL		VNAP	
Study Description	(0008,1030)	LO	MWL, AUTO, CONFIG		ANAP	
Physician(s) of Record	(0008,1048)	PN	MWL		ANAP	
Requesting Service	(0032,1033)	LO	MWL		ANAP	
Referenced Study Sequence	(0008,1110)	SQ	MWL		ANAP	
>Referenced SOP Class UID	(0008,1150)	UI	MWL		ALWAYS	
>Referenced SOP Instance UID	(0008,1155)	UI	MWL		ALWAYS	
Procedure Code Sequence	(0008,1032)	SQ	MWL		ANAP	
>Code Value	(0008,0100)	SH	MWL		ALWAYS	
>Coding Scheme Designator	(0008,0102)	SH	MWL		ALWAYS	
>Code Meaning	(0008,0104)	LO	MWL		ALWAYS	

9.1.1.1.3 Module Patient Study (Common for CT Image, SC Image, SR, CSA Non-Image)

Table 77 The table in this section lists all attributes that are supported in the Patient Study Module for the IODs:

- CT Image
- Secondary Capture Image

- X-Ray Radiation Dose SR
- Radiopharmaceutical Radiation Dose SR
- Comprehensive SR
- CSA Non-Image

Table 77: Patient Study Module Attributes

Attribute Name	Tag	VR	Source	Value	Presence	Comments
Patient's Age	(0010,1010)	AS	AUTO		ALWAYS	Calc from birthdate and current date/time
Patient's Size	(0010,1020)	DS	MWL		ANAP	
Patient's Weight	(0010,1030)	DS	MWL		ANAP	in kg
Pregnancy Status	(0010,21C0)	US	MWL	1,2,3,4	ANAP	
Additional Patient History	(0010,21B0)	LT	MWL		ANAP	

9.1.1.1.4 CSA Image Header Module (private; for CT Image, SC Image, CSA Non-Image)

The table in this section contains private Attributes that are supported in the CSA Image Header Module for the IODs:

- CT Image
- Secondary Capture Image
- CSA Non-Image

Table 78: CSA Image Header Module

Attribute Name	Tag	Private Creator Identifier	VR	Source	Value	Presence	Comments
CSA Image Header Type	(0029,xx08)	SIEMENS CSA HEADER	CS	AUTO	NUM 4, SOM 7	ALWAYS	CSA Image Header identification characteristics. Defined Terms: NUM 4 = NUMARIS/4 SOM 7 = Somaris/7 or Biograph Vision
CSA Image Header Version	(0029,xx09)	SIEMENS CSA HEADER	LO	AUTO		ALWAYS	Version of CSA Image Header Info (0029,xx10) format.
CSA Image Header Info	(0029,xx10)	SIEMENS CSA HEADER	OB	AUTO		ALWAYS	Manufacturer Model dependent information.

9.1.1.1.5 CSA Series Header Module (private; for CT Image, SC Image)

The table in this section contains private Attributes that are supported in the CSA Series Header Module for the IODs:

- CT Image
- Secondary Capture Image

Table 79: CSA Series Header Module

Attribute Name	Tag	Private Creator Identifier	VR	Source	Value	Presence	Comments
CSA Series Header Type	(0029,xx18)	SIEMENS CSA HEADER	CS	AUTO	NUM 4, SOM 7	ANAP	CSA Series Header identification characteristics. Defined Terms: NUM 4 = NUMARIS/4 SOM 7 = Somaris/7
CSA Series Header Version	(0029,xx19)	SIEMENS CSA HEADER	LO	AUTO		ANAP	Version of CSA Series Header Info (0029,xx20) format.
CSA Series Header Info	(0029,xx20)	SIEMENS CSA HEADER	OB	AUTO		ANAP	Manufacturer Model dependent information.

9.1.1.1.6 MEDCOM Header Module (private; for CT Image, SC Image)

The table in this section contains private Attributes that are supported in the MEDCOM Header Module for the IODs:

- CT Image
- Secondary Capture Image

Table 80: MEDCOM Header Module

Attribute Name	Tag	Private Creator Identifier	VR	Source	Value	Presence	Comments
MedCom Header Type	(0029,xx08)	SIEMENS MEDCOM HEADER	CS	AUTO	MEDCOM 1	ANAP	MedCom Header identification characteristics. Present if MedCom Header Info (0029,xx10) present.
MedCom Header Version	(0029,xx09)	SIEMENS MEDCOM HEADER	LO	AUTO		ANAP	Version of MedCom Header Info (0029,xx10) format. Present if MEDCOM Header Info (0029,xx10) present.
MedCom Header Info	(0029,xx10)	SIEMENS MEDCOM HEADER	OB	AUTO		ANAP	Manufacturer model dependent information. The value of the attribute MedCom Header Info

Attribute Name	Tag	Private Creator Identifier	VR	Source	Value	Presence	Comments
							(0029,xx10) can be build up in each user defined format.
MedCom History Information	(0029,xx20)	SIEMENS MEDCOM HEADER	OB	AUTO		ANAP	MedCom defined Patient Registration history information.
PMTF Information 1	(0029,xx31)	SIEMENS MEDCOM HEADER	LO	AUTO		ANAP	Transformation Information
PMTF Information 2	(0029,xx32)	SIEMENS MEDCOM HEADER	UL	AUTO		ANAP	Transformation Information
PMTF Information 3	(0029,xx33)	SIEMENS MEDCOM HEADER	UL	AUTO		ANAP	Transformation Information
PMTF Information 4	(0029,xx34)	SIEMENS MEDCOM HEADER	CS	AUTO		ANAP	Transformation Information
Application Header Sequence	(0029,xx40)	SIEMENS MEDCOM HEADER	SQ	AUTO		ANAP	Sequence of Application Header Items. Zero or more Items shall be included in this sequence. Encoded as a sequence of items.
>Application Header Type	(0029,xx41)	SIEMENS MEDCOM HEADER	CS	AUTO		ANAP	Application Header identification characteristics. Present if Sequence is sent.
>Application Header ID	(0029,xx42)	SIEMENS MEDCOM HEADER	LO	AUTO		ANAP	Identification of an application header.
>Application Header Version	(0029,xx43)	SIEMENS MEDCOM HEADER	LO	AUTO		ANAP	Version of Application Header Info (0029,xx43) format.
>Application Header Info	(0029,xx44)	SIEMENS MEDCOM HEADER	OB	AUTO		ANAP	Application dependent information.
Workflow Control Flags	(0029,xx50)	SIEMENS MEDCOM HEADER	LO	AUTO		ANAP	Eight free definable flags.

Attribute Name	Tag	Private Creator Identifier	VR	Source	Value	Presence	Comments
Archive Management Flag Keep Online	(0029,xx51)	SIEMENS MEDCOM HEADER	CS	AUTO	00, 01	ANAP	Flag to control remote archive management system to keep the image always online (also when already archived). Enumerated Values: 00 = remote control not required 01 = keep image online.
Archive Management Flag Do Not Archive	(0029,xx52)	SIEMENS MEDCOM HEADER	CS	AUTO	00, 01	ANAP	Flag to control remote archive management system not to archive the related image. Enumerated Values: 00 = remote control not required 01 = don't archive image.
Image Location Status	(0029,xx53)	SIEMENS MEDCOM HEADER	CS	AUTO	ONLINE, NEARLINE, OFFLINE, INVALID	ANAP	Image location status to control retrieving. Defined Terms: ONLINE = retrieving has to be done as usual NEARLINE = move request to SCP and delay according to value of Estimated Retrieve Time (0029,xx54) OFFLINE = invoking a retrieve operation initiates an operator request INVALID = invoking a retrieve operation would always result in an error.
Estimated Retrieve Time	(0029,xx54)	SIEMENS MEDCOM HEADER	DS	AUTO		ANAP	Estimated retrieve time in seconds. A value less than zero (< 0) indicates location is OFFLINE or INVALID.
Data Size of Retrieved Images	(0029,xx55)	SIEMENS MEDCOM HEADER	DS	AUTO		ANAP	Data size of images in MByte.
Siemens Link Sequence	(0029,xx70)	SIEMENS MEDCOM HEADER	SQ	AUTO		ANAP	Sequence of Link items. Each item identifies the location of the location of one missing tag. One or more items can be located in this sequence.

Attribute Name	Tag	Private Creator Identifier	VR	Source	Value	Presence	Comments
Referenced Tag	(0029,xx71)	SIEMENS MEDCOM HEADER	AT	AUTO		ANAP	The referenced tag. The value of this tag is in the Child Data Object (CDO). If present, currently it is always Pixel Data (7FE0,0010).
Referenced Tag Type	(0029,xx72)	SIEMENS MEDCOM HEADER	CS	AUTO		ANAP	The value representation (type) of the missing tag (e.g. OW). Enumerated values are all DICOM defined Value Representations.
Referenced Value Length	(0029,xx73)	SIEMENS MEDCOM HEADER	UL	AUTO		ANAP	The length of the referenced tag value in bytes.
Referenced Object Device Type	(0029,xx74)	SIEMENS MEDCOM HEADER	CS	AUTO	SHMEM, SDM, LOID, FILE	ANAP	The Device Type that stores the Child Data Object (CDO) with the referenced tag value. Currently it should be "SHMEM". In future, "SDM", "LOID" or "FILE" are also imaginable. Defined Terms are SHMEM = Shared Memory SDM = Series Data Management LOID = Database FILE
Referenced Object Device Location	(0029,xx75)	SIEMENS MEDCOM HEADER	OB	AUTO		ANAP	The Location of the device that stores the Child Data Object (CDO) with the referenced tag value. For the "SHMEM" case, it is the shared memory directory. Can be empty, then the default directory will be taken. In future, for "SDM" this will be the SDM_ID, for FILE it will be the directory name and for "LOID" it will be the database name.
Referenced Object ID	(0029,xx76)	SIEMENS MEDCOM HEADER	OB	AUTO		ANAP	The ID of the object that contains the Child Data Object (CDO) with the referenced tag value. In case of "SHMEM", it is the shared memory ID.

Attribute Name	Tag	Private Creator Identifier	VR	Source	Value	Presence	Comments
							In future, for "SDM" this will be a Sirius OID, for "FILE" the file name, for "DB" the LOID.
Series Work Flow Status	(0029,xx60)	SIEMENS MEDCOM HEADER2	LO	AUTO	com, rea, ver	ANAP	Biograph Vision Patient Browser specific flags used for clinical work: - com = completed - rea = read - ver = verified

9.1.1.1.7 MEDCOM OOG Module (private; for CT Image, SC Image)

The table in this section contains private Attributes that are supported in the MEDCOM Object Oriented Graphics (OOG) Module for the IODs:

- CT Image
- Secondary Capture Image

This module is used when object graphics is drawn on the image and need to be stored as graphic object properties (Line, Circle, Rectangle, Arrow, and so on). Given the condition that the module contents was not removed by other modalities, the graphic objects remain re-animatable if such an image was transferred and is then retrieved back.

Table 81: MEDCOM OOG Module

Attribute Name	Tag	Private Creator Identifier	VR	Source	Value	Presence	Comments
MedCom OOG Type	(0029,xx08)	SIEMENS MEDCOM OOG	CS	AUTO	MEDCOM OOG 1, MEDCOM OOG 2	ANAP	MEDCOM Object Oriented Graphics (OOG) identification characteristics. Present if module is present.
MedCom OOG Version	(0029,xx09)	SIEMENS MEDCOM OOG	LO	AUTO		ANAP	Version of MEDCOM OOG Info (0029,xx10) format.
MedCom OOG Info	(0029,xx10)	SIEMENS MEDCOM OOG	OB	AUTO		ANAP	MEDCOM Object Oriented Graphics (OOG) data.

The graphics objects are also stored in one Image overlay plane for compatibility with other products, which don't support the MedCom OOG module. Any system which does not support this MedCom OOG module has to remove these private attributes when modifying the image overlay plane content.

9.1.1.1.8 syngo Report Data (private; for SC Image, SR)

The module contains private Attributes that are supported in *syngo* reports for the IODs:

- Secondary Capture Image
- X-Ray Radiation Dose SR
- Radiopharmaceutical Radiation Dose SR
- Comprehensive SR

This module is used when *syngo* report data are added to DICOM SR and DICOM SC Image objects.

Table 82: syngo Report Data

Attribute Name	Tag	Private Creator Identifier	VR	Source	Value	Presence	Comments
<i>syngo</i> Report Type	(0029,xx08)	SIEMENS CSA REPORT	CS	AUTO	CT_CASCORING, CT_CIRCULATION, CT_LUNG CARE, CT_ONCOLOGY, CTDOSEREPORT, NMDOSEREPORT, Known from other products: INSPACE, MR_ARGUS	ANAP	<i>syngo</i> report characteristics, e.g., report creating application. This attribute value will be used to identify the corresponding application during generic extension dll management. A restricted character set is used: only A-Z and underscore are supported. Present if module is present.
<i>syngo</i> Report Version	(0029,xx09)	SIEMENS CSA REPORT	LO	AUTO		ANAP	Version of <i>syngo</i> Report Data (0029,xx10) format.
<i>syngo</i> Report Data	(0029,xx10)	SIEMENS CSA ENVELOPE	OB	AUTO		ANAP	Application specific report related data
<i>syngo</i> Report Presentation	(0029,xx11)	SIEMENS CSA ENVELOPE	OB	AUTO		ANAP	Application specific report related data

Attribute Name	Tag	Private Creator Identifier	VR	Source	Value	Presence	Comments
SR Variant	(0029,xx15)	SIEMENS CSA REPORT	US	AUTO	0, 1, 2, 3, 4, 5, 6, 7, 8	ANAP	<p>DICOM SR Variant.</p> <p>Enumerated Values:</p> <p>0 = Basic Text SR (1.2.840.1008.5.1.4.1.1.88.11)</p> <p>1 = Enhanced SR (1.2.840.1008.5.1.4.1.1.88.22)</p> <p>2 = Comprehensive SR (1.2.840.1008.5.1.4.1.1.88.33)</p> <p>3 = Mammography CAD SR (1.2.840.1008.5.1.4.1.1.88.50)</p> <p>4 = Key Object Selection Document (1.2.840.1008.5.1.4.1.1.88.59)</p> <p>5 = Chest CAD SR (1.2.840.1008.5.1.4.1.1.88.65)</p> <p>6 = X-Ray Radiation Dose SR (1.2.840.1008.5.1.4.1.1.88.67)</p> <p>7 = Procedure Log (1.2.840.1008.5.1.4.1.1.88.40)</p> <p>8 = Radiopharmaceutical Radiation Dose SR (1.2.840.1008.5.1.4.1.1.88.68)</p>
SC SOP Instance UID	(0029,xx17)	SIEMENS CSA REPORT	UI	AUTO		ANAP	<p>DICOM SOP Instance UID of syngo based SC image representing the syngo report object.</p> <p>This UID will be used to identify the Resulting SC object after SR to SC conversion.</p>

9.1.1.2 CT Image IOD

The following table specifies the Modules supported in the CT Image IOD

Table 83: CT Image IOD Modules

IE	Module	Reference	Presence of Module
Patient	Patient	Table 75	ALWAYS
Study	General Study	Table 76	ALWAYS
	Patient Study	Table 77	ALWAYS
Series	General Series	Table 84	ALWAYS
	CSA Series Header (P)	Table 79	U – when content available
Frame of Reference	Frame of Reference	Table 85	ALWAYS
Equipment	General Equipment	Table 86	ALWAYS
Acquisition	General Acquisition	Table 87: General Acquisition Module Attributes – CT Image	ALWAYS
Image	General Image	Table 88	ALWAYS
	General Reference	Table 89	C – Not used for Topogram
	Image Plane	Table 90	ALWAYS
	Image Pixel	Table 91	ALWAYS
	Contrast/Bolus	Table 92	C – If contrast media was used in this image
	CT Image	Table 93	ALWAYS
	Overlay Plane	Table 94	C – Not used for Topogram
	VOI LUT	Table 95	ALWAYS
	SOP Common	Table 96	ALWAYS
	CSA Image Header (P)	Table 78	ALWAYS
	MEDCOM Header (P)	Table 80	U – when content available
	MEDCOM OOG (P)	Table 81	U – when content available
	CT Extensions (P)	Table 97	ALWAYS
	Merge Multi CT Tool	Table 98	C – If the Merge Multi CT Tool is used

9.1.1.2.1 Module General Series (CT Image)

Table 84: General Series Module Attributes – CT Image

Attribute Name	Tag	VR	Source	Value	Presence	Comments
Modality	(0008,0060)	CS	AUTO	“CT”	ALWAYS	
Series Instance UID	(0020,000E)	UI	AUTO	1.3.12.2.1107.5.1.4.Device Serial Number.Object Identifier	ALWAYS	

Attribute Name	Tag	VR	Source	Value	Presence	Comments
Series Number	(0020,0011)	IS	AUTO	1 – N	ALWAYS	
Laterality	(0020,0060)	CS	AUTO		ANAP	Empty if present
Series Date	(0008,0021)	DA	AUTO		ALWAYS	Local date when series was created
Series Time	(0008,0031)	TM	AUTO		ALWAYS	Format: hhmmss.nnnnnn
Protocol Name	(0018,1030)	LO	AUTO, CONFIG		ALWAYS	Example: “Onco_LowDose”
Series Description	(0008,103E)	LO	AUTO, CONFIG		ALWAYS	
Referenced Performed Procedure Step Sequence	(0008,1111)	SQ	MPPS		ANAP	If MPPS
>Referenced SOP Class UID	(0008,1150)	UI	MPPS	“1.2.840.10008.3.1.2.3.3” = MPPS SOP Class		
>Referenced SOP Instance UID	(0008,1155)	UI	MPPS			
Body Part Examined	(0018,0015)	CS	AUTO		ALWAYS	See 9.5.1.1.2 Body Part Examined
Patient Position	(0018,5100)	CS	AUTO		ALWAYS	See DICOM PS3.3 C.7.3.1.1.2 Patient Position
Request Attributes Sequence	(0040,0275)	SQ	MWL		ANAP	
>Requested Procedure ID	(0040,1001)	SH	MWL		ANAP	
>Scheduled Procedure Step ID	(0040,0009)	SH	MWL		ANAP	
>Scheduled Procedure Step Description	(0040,0007)	SH	MWL		ANAP	
>Scheduled Protocol Code Sequence	(0040,0008)	SQ	MWL		ANAP	
>>Code Value	(0008,0100)	SH	MWL		ANAP	
>>Coding Scheme Designator	(0008,0102)	SH	MWL		ANAP	
>>Code Meaning	(0008,0104)	LO	MWL		ANAP	

9.1.1.2.2 Module Frame of Reference (CT Image)

Table 85: Frame of Reference Module Attributes – CT Image

Attribute Name	Tag	VR	Source	Value	Presence	Comments
Frame of Reference UID	(0020,0052)	UI	AUTO	"1.3.12.2.1107.5.1.4."+UID	ALWAYS	
Position Reference Indicator	(0020,1040)	LO	AUTO	Position, or empty	VNAP	

9.1.1.2.3 Module General Equipment (CT Image)

Table 86: General Equipment Module Attributes – CT Image

Attribute Name	Tag	VR	Source	Value	Presence	Comments
Manufacturer	(0008,0070)	LO	AUTO	"SIEMENS" ¹	ALWAYS	
Institution Name	(0008,0080)	LO	CONFIG		ALWAYS	
Institution Address	(0008,0081)	LO	CONFIG		ALWAYS	
Station Name	(0008,1010)	SH	CONFIG		ALWAYS	
Manufacturer's Model Name	(0008,1090)	LO	AUTO	One of the following based on system type Example: "Biograph20_Vision 3R" "Biograph20_Vision 4R" "Biograph40_Vision 3R" "Biograph40_Vision 4R" "Biograph64_Vision 3R" "Biograph64_Vision 4R" "Biograph128_Vision 3R" "Biograph128_Vision 4R" "Biograph128_Vision 3R Edge" "Biograph128_Vision 4R Edge"	ALWAYS	
Device Serial Number	(0018,1000)	LO	CONFIG		ALWAYS	
Software Versions	(0018,1020)	LO	AUTO	"VG85A"	ALWAYS	
Date of Last Calibration	(0018,1200)	DA	AUTO		ALWAYS	
Time of Last Calibration	(0018,1201)	TM	AUTO		ALWAYS	

¹ Might be replaced by "Siemens Healthineers" in future versions

9.1.1.2.4 Module General Acquisition (CT Image)

Table 87: General Acquisition Module Attributes – CT Image

Attribute Name	Tag	VR	Source	Value	Presence	Comments
Acquisition Number	(0020,0012)	IS	AUTO	1 – N	ALWAYS	
Acquisition Date	(0008,0022)	DA	AUTO		ALWAYS	Date when acquisition occurred
Acquisition Time	(0008,0032)	TM	AUTO		ALWAYS	Format: hhmmss.nnnnnn
Acquisition DateTime	(0008,002A)	DT	AUTO		ANAP	Format: yyyymmddhhmmss.nnnnnn
Irradiation Event UID	(0008,3010)	UI	AUTO	“1.3.12.2.1107.5.1.4.”+UID	ALWAYS	

9.1.1.2.5 Module General Image (CT Image)

Table 88: General Image Module Attributes – CT Image

Attribute Name	Tag	VR	Source	Value	Presence	Comments
Instance Number	(0020,0013)	IS	AUTO	1 – N	ALWAYS	
Patient Orientation	(0020,0020)	CS	AUTO		ANAP	
Content Date	(0008,0023)	DA	AUTO		ALWAYS	Date when content was created; for original reconstructed images date of corresponding radiation event is used
Content Time	(0008,0033)	TM	AUTO		ALWAYS	Format: hhmmss.nnnnnn
Image Type	(0008,0008)	CS	AUTO		ALWAYS	See below
Image Comments	(0020,4000)	LT	USER		VNAP	
Lossy Image Compression	(0028,2110)	CS	AUTO, CONFIG	00 = No, 01 = Yes	ANAP	Not for Topogram

Values for Image Type

(0008,0008) Image Type
 ORIGINAL\PRIMARY\LOCALIZER\CT_SOM5 TOP
 DERIVED\PRIMARY\AXIAL\CT_SOM5 SPI

9.1.1.2.6 Module General Reference (CT Image)

Table 89: General Reference Module Attributes – CT Image

Attribute Name	Tag	VR	Source	Value	Presence	Comments
Referenced Image Sequence	(0008,1140)	SQ	AUTO		ANAP	Not present for Topogram
> Referenced SOP Class UID	(0008,1150)	UI	AUTO	1.2.840.10008.5.1.4.1.1.2=CTImageStorage	ALWAYS	

> Referenced SOP Instance UID	(0008,1155)	UI	AUTO	"1.3.12.2.1107.5.1.4."+UID	ALWAYS	Reference to (0008,0018) SOPInstanceUID of Topogram in the study
Derivation Description	(0008,2111)	ST	AUTO		ANAP	
Source Image Sequence	(0008,2112)	SQ	AUTO		ANAP	Not present for Topogram
> Referenced SOP Class UID	(0008,1150)	UI	AUTO	1.2.840.10008.5.1.4.1.1.2=CTImageStorage	ALWAYS	
> Referenced SOP Instance UID	(0008,1155)	UI	AUTO	"1.3.12.2.1107.5.1.4."+UID	ALWAYS	Reference to (0008,3010) IrradiationEventUID of the study

9.1.1.2.7 Module Image Plane (CT Image)

Table 90: Image Plane Module Attributes – CT Image

Attribute Name	Tag	VR	Source	Value	Presence	Comments
Pixel Spacing	(0028,0030)	DS	AUTO	N\N	ALWAYS	
Image Orientation (Patient)	(0020,0037)	DS	AUTO	N\N\N\N\N\N	ALWAYS	
Image Position (Patient)	(0020,0032)	DS	AUTO	N\N\N	ALWAYS	
Slice Thickness	(0018,0050)	DS	AUTO		VNAP	Empty for Topogram
Slice Location	(0020,1041)	DS	AUTO	N	ALWAYS	

9.1.1.2.8 Module Image Pixel (CT Image)

Table 91: Image Pixel Module Attributes – CT Image

Attribute Name	Tag	VR	Source	Value	Presence	Comment
Samples per Pixel	(0028,0002)	US	AUTO	1	ALWAYS	
Photometric Interpretation	(0028,0004)	CS	AUTO	"MONOCHROME2"	ALWAYS	
Rows	(0028,0010)	US	AUTO	"512" or "1024"	ALWAYS	
Columns	(0028,0011)	US	AUTO	"512" or "1024"	ALWAYS	
Bits Allocated	(0028,0100)	US	AUTO	"16"	ALWAYS	
Bits Stored	(0028,0101)	US	AUTO	"12"	ALWAYS	
High Bit	(0028,0102)	US	AUTO	"11"	ALWAYS	
Pixel Representation	(0028,0103)	US	AUTO	"0" =unsigned integer	ALWAYS	
Smallest Image Pixel Value	(0028,0106)	US	AUTO		ANAP	Not present for Topogram

Attribute Name	Tag	VR	Source	Value	Presence	Comment
Largest Image Pixel Value	(0028,0107)	US	AUTO		ANAP	Not present for Topogram
Pixel Data	(7FE0,0010)	OW	AUTO		ALWAYS	

9.1.1.2.9 Module Contrast/Bolus (CT Image)

This module is present, if contrast media was used in this image

Table 92: Contrast/Bolus Module Attributes – CT Image

Attribute Name	Tag	VR	Source	Value	Presence	Comments
Contrast/Bolus Agent	(0018,0010)	LO	AUTO, USER		ALWAYS	Examples: "APPLIED"
Contrast/Bolus Volume	(0018,1041)	DS	AUTO		ALWAYS	
Contrast Flow Rate	(0018,1046)	DS	AUTO		ALWAYS	
Contrast Flow Duration	(0018,1047)	DS	AUTO		ALWAYS	
Contrast/Bolus Ingredient Concentration	(0018,1049)	DS	AUTO		ALWAYS	

9.1.1.2.10 Module CT Image (CT Image)

Table 93: CT Image Module Attributes – CT Image

Attribute Name	Tag	VR	Source	Value	Presence	Comments
Image Type	(0008,0008)	CS	AUTO		ALWAYS	See Section 9.5.1.1.1 for further explanation.
Samples per Pixel	(0028,0002)	US	AUTO	"1"	ALWAYS	
Photometric Interpretation	(0028,0004)	CS	AUTO	"MONOCHROME2"	ALWAYS	
Bits Allocated	(0028,0100)	US	AUTO	"16"	ALWAYS	
Bits Stored	(0028,0101)	US	AUTO	"12"	ALWAYS	
High Bit	(0028,0102)	US	AUTO	"11"	ALWAYS	
Rescale Intercept	(0028,1052)	DS	AUTO		ALWAYS	Example: "-1024"
Rescale Slope	(0028,1053)	DS	AUTO	"1"	ALWAYS	
Rescale Type	(0028,1054)	LO	AUTO	"HU"	ALWAYS	
KVP	(0018,0060)	DS	AUTO		ALWAYS	Example: "120"
Acquisition Number	(0020,0012)	IS	AUTO	1 – N	ALWAYS	

Attribute Name	Tag	VR	Source	Value	Presence	Comments
Data Collection Diameter	(0018,0090)	DS	AUTO		ALWAYS	Example: "500"
Data Collection Center (Patient)	(0018,9313)	FD	AUTO	N\N\N	ANAP	Not for Topogram
Reconstruction Diameter	(0018,1100)	DS	AUTO		ALWAYS	Example: "1024"
Reconstruction Target Center (Patient)	(0018,9318)	FD	AUTO	N\N\N	ANAP	Not for Topogram
Distance Source to Detector	(0018,1110)	DS	AUTO		ALWAYS	
Distance Source to Patient	(0018,1111)	DS	AUTO		ALWAYS	
Gantry/Detector Tilt	(0018,1120)	DS	AUTO		ALWAYS	
Table Height	(0018,1130)	DS	AUTO		ALWAYS	Example: "100"
Rotation Direction	(0018,1140)	CS	AUTO	"CW"	ALWAYS	
Exposure Time	(0018,1150)	IS	AUTO		ALWAYS	
X-Ray Tube Current	(0018,1151)	IS	AUTO		ALWAYS	
Exposure	(0018,1152)	IS	AUTO		ALWAYS	
Filter Type	(0018,1160)	SH	AUTO		ALWAYS	Example: "FLAT"
Generator Power	(0018,1170)	IS	AUTO		ALWAYS	
Focal Spot(s)	(0018,1190)	DS	AUTO		ALWAYS	
Convolution Kernel	(0018,1210)	SH	AUTO		ALWAYS	Examples: "Tr60f", "Br38f"
Single Collimation Width	(0018,9306)	FD	AUTO		ALWAYS	
Total Collimation Width	(0018,9307)	FD	AUTO		ALWAYS	
Table Speed	(0018,9309)	FD	AUTO		ALWAYS	
Table Feed per Rotation	(0018,9310)	FD	AUTO		ANAP	Not for Topogram
Spiral Pitch Factor	(0018,9311)	FD	AUTO		ALWAYS	
Exposure Modulation Type	(0018,9323)	CS	AUTO		ALWAYS	Examples: "NONE", "XYZ_EC"
CTDI vol	(0018,9345)	FD	AUTO		ALWAYS	
CTDI Phantom Type Code Sequence	(0018,9346)	SQ	AUTO		ALWAYS	

Attribute Name	Tag	VR	Source	Value	Presence	Comments
>Code Value	(0008,0100)	SH	AUTO	"113691"	ALWAYS	
>Coding Scheme Designator	(0008,0102)	SH	AUTO	"DCM"	ALWAYS	
>Code Meaning	(0008,0104)	LO	AUTO	"IEC Body Dosimetry Phantom"	ALWAYS	
Calcium Scoring Mass Factor Device	(0018,9352)	FL	AUTO	Num \ num \ num	ALWAYS	

9.1.1.2.11 Module Overlay Plane (CT Image)

This module is not present if the CT image is a topogram. The overlay is usually placed in the (6000,eeee) group.

Table 94: Overlay Plane Module Attributes – CT Image

Attribute Name	Tag	VR	Source	Value	Presence	Comments
Overlay Rows	(60xx,0010)	US	AUTO	"512" or "1024"	ALWAYS	
Overlay Columns	(60xx,0011)	US	AUTO	"512" or "1024"	ALWAYS	
Overlay Description	(60xx,0022)	LO	AUTO	"Siemens MedCom Object Graphics"	ALWAYS	
Overlay Type	(60xx,0040)	CS	AUTO	"G" = Graphics	ALWAYS	
Overlay Origin	(60xx,0050)	SS	AUTO	"1\1"	ALWAYS	
Overlay Bits Allocated	(60xx,0100)	US	AUTO	"1"	ALWAYS	
Overlay Bit Position	(60xx,0102)	US	AUTO	"0"	ALWAYS	
Overlay Data	(60xx,3000)	OW	AUTO		ALWAYS	

9.1.1.2.12 Module VOI LUT (CT Image)

Table 95: VOI LUT Module Attributes – CT Image

Attribute Name	Tag	VR	Source	Value	Presence	Comments
Window Center	(0028,1050)	DS	AUTO	N \ N	ALWAYS	
Window Width	(0028,1051)	DS	AUTO	N \ N	ALWAYS	
Window Center & Width Explanation	(0028,1055)	LO	AUTO	"WINDOW1\WINDOW2"	ALWAYS	

9.1.1.2.13 Module SOP Common (CT Image)

Table 96: SOP Common Module Attributes – CT Image

Attribute Name	Tag	VR	Source	Value	Presence	Comments
SOP Class UID	(0008,0016)	UI	AUTO	1.2.840.10008.5.1.4.1.1.2 =CTImageStorage	ALWAYS	

SOP Instance UID	(0008,0018)	UI	AUTO	"1.3.12.2.1107.5.1.4."+UID	ALWAYS	
Specific Character Set	(0008,0005)	CS	CONFIG MWL		ALWAYS	
Instance Number	(0020,0013)	IS	AUTO	1 – N	ALWAYS	

9.1.1.2.14 Extensions to CT Image IOD

Table 97: Extension attributes for CT Image IOD

Attribute Name	Tag	VR	Source	Value	Presence	Comments
Other Patient IDs (RETIRED)	(0010,1000)	LO	MWL		ANAP	Only if present on MWL
Estimated Dose Saving (RETIRED)	(0018,9324)	FD	AUTO	"0"	ALWAYS	For legacy reasons
Requesting Physician	(0032,1032)	PN	MWL		ANAP	Only if present on MWL
Requesting Service	(0032,1033)	LO	MWL		ANAP	Only if present on MWL
Requested Procedure Description	(0032,1060)	LO	MWL		ANAP	Only if present on MWL
Requested Procedure Code Sequence	(0032,1064)	LO	MWL		ANAP	Only if present on MWL
>Code Value	(0008,0100)	SH	MWL		ANAP	
>Coding Scheme Designator	(0008,0102)	SH	MWL		ANAP	
>Code Meaning	(0008,0104)	LO	MWL		ANAP	
Number of Frames in Overlay	(60xx,0015)	US	AUTO	"1"	ALWAYS	To be changed
Image Frame Origin	(60xx,0051)	US	AUTO	"1"	ALWAYS	To be changed

Notes:

- The attributes
 - OtherPatientIDs
 - RequestingPhysician
 - RequestingService
 - RequestedProcedureDescription
 - RequestedProcedureCodeSequence
are used due to legacy reasons for existing customers. They may be removed in future versions of our implementation.
- The attribute EstimatedDoseSaving was retired in DICOM standard and is pending to be removed from our implementation

- The attributes NumberOfFramesinOverlay and ImageFrameOrigin will be removed in future versions, as they are not needed for IOD CTImage, which is not a multi-frame.

9.1.1.2.15 Instance created by the Merge Multi CT Tool

The following section describes attribute interpretations for CT images generated by Merge Multi CT tool.

Multiple CT series are merged into one (Result Series) that is used for attenuation correction during creation of PET images.

The series level attributes are copied from the original CT series that contains the image with the lowest (most negative) Slice Location (0020, 1041) value.

The image level attributes are copied from the source CT image.

Following attributes are updated, changed, or removed relative to the original CT image:

Table 98 : Instance created by the Merge Multi CT Tool

Attribute Name	Tag	VR	Source	Value	Presence	Comments
Series Description	(0008, 103E)	LO	USER		ALWAYS	Supplied by user
Body Part Examined	(0018, 0015)	CS	USER/AUTO		ANAP	Removed
Series Number	(0020, 0011)	IS	AUTO		ALWAYS	Set in range 0-500, the lowest unused number
Image Type	(0008, 0008)	CS	AUTO	DERIVED	ALWAYS	
Image Date (Content Date)	(0008, 0023)	DA	AUTO		ALWAYS	Current date when result image is created
Image Time (Content Time)	(0008, 0033)	TM	AUTO		ALWAYS	Current time when result image is created
Image Number (Instance Number)	(0020, 0013)	IS	AUTO		ALWAYS	Craniocaudal: Image order increases with increase of Z-position of image slice. Caudocranial: Image order decreases with increase of Z-position of image slice
Source Image Sequence	(0008, 2112)	ST	AUTO		ALWAYS	1.2.840.10008.5.1.4.1.1.2 SOP Instance - UID of the CT series (original one) that slice is generated from
Reference Image Sequence	(0008, 1140)	SQ	AUTO		ANAP	Removed if set

Derivation Description	(0008, 2111)	ST	AUTO	MULTI CT FOR AC	ALWAYS	
Image Comment	(0020, 4000)	LT	AUTO		ALWAYS	Image comment from the original image (1st slice), appended series description from the original CT series that slice is generated from. ^ is used as delimiter
Largest Image Pixel Value	(0028, 0107)	US	AUTO		ANAP	Removed if set
Smallest Image Pixel Value	(0028, 0106)	US	AUTO		ANAP	Removed if set
Slice Thickness	(0018, 0050)	DS	USER		ALWAYS	Supplied by user
Image Position Patient	(0020, 0032)	DS	AUTO		ALWAYS	Replaced the 3rd value in the array, a new calculated z-position
KVP	(0018,0060)	DS	AUTO		ALWAYS	Read from the source CT image.
Scan Options	(0018,0022)	CS	AUTO		ANAP	Removed if set
Data Collection Diameter	(0018,0090)	DS	AUTO		ANAP	Removed if set
Data Collection Center	(0018,9313)	FD	AUTO		ANAP	Removed if set
Reconstruction Diameter	(0018,1100)	DS	AUTO		ALWAYS	Read from the source CT image.
Reconstruction Target Center (Patient)	(0018,9318)	FD	AUTO		ANAP	Removed if set
Distance Source to Detector	(0018,1110)	DS	AUTO		ANAP	Removed if set
Distance Source to Patient	(0018,1111)	DS	AUTO		ANAP	Removed if set
Gantry/Detector Tilt	(0018,1120)	DS	AUTO		ANAP	Removed if set
Table Height	(0018,1130)	DS	AUTO		ALWAYS	Read from the source CT image.
Rotation Direction	(0018,1140)	CS	AUTO		ANAP	Removed if set
Exposure Time	(0018,1150)	IS	AUTO		ANAP	Removed if set
X-Ray Tube Current	(0018,1151)	IS	AUTO		ANAP	Removed if set
Exposure	(0018,1152)	IS	AUTO		ANAP	Removed if set

Exposure in uAs	(0018,1153)	DS	AUTO		ANAP	Removed if set
Filter Type	(0018,1160)	SH	AUTO		ANAP	Removed if set
Generator Power	(0018,1170)	IS	AUTO		ANAP	Removed if set
Focal Spots	(0018,1190)	DS	AUTO		ANAP	Removed if set
Convolution Kernel	(0018,1210)	SH	AUTO		ANAP	Removed if set
Revolution Time	(0018,9305)	FD	AUTO		ANAP	Removed if set
Single Collimation Width	(0018,9306)	FD	AUTO		ANAP	Removed if set
Total Collimation Width	(0018,9307)	FD	AUTO		ANAP	Removed if set
Table Speed	(0018,9309)	FD	AUTO		ANAP	Removed if set
Table Feed per Rotation	(0018,9310)	FD	AUTO		ANAP	Removed if set
Spiral Pitch Factor	(0018,9311)	FD	AUTO		ANAP	Removed if set
Exposure Modulation Type	(0018,9323)	CS	AUTO		ANAP	Removed if set
Estimated Dose Saving	(0018,9324)	FD	AUTO		ANAP	Removed if set
CTDIvol	(0018,9345)	FD	AUTO		ANAP	Removed if set
CTDI Phantom Type Code Sequence	(0018,9346)	SQ	AUTO		ANAP	Removed if set
Calcium Scoring Mass Factor Patient	(0018,9351)	FL	AUTO		ANAP	Removed if set
Calcium Scoring Mass Factor Device	(0018,9352)	FL	AUTO		ANAP	Removed if set
Energy Weighting Factor	(0018,9353)	FL	AUTO		ANAP	Removed if set
CT Additional X-Ray Source Sequence	(0018,9360)	SQ	AUTO		ANAP	Removed if set
Isocenter Position	(300A,012C)	DS	AUTO		ANAP	Removed if set

9.1.1.3 Secondary Capture Image IOD

The IOD Secondary Capture which is created by Biograph Vision is used for these purposes:

- X-Ray Dose information, as table in OverlayData
- PET Count Rate Statistics
- PET NAC Reconstruction Parameters
- PET AC Reconstruction Parameters
- PET Radiopharmaceutical Dose Report

They have parameter tables and drawings encoded as image pixels, respectively overlay pixels. As Secondary Capture Images are supported by most IHE Image Display providers, these data can be displayed as “image” – even if Structured Reports (SR) or other IODs cannot be displayed.

Table 99 The following table specifies the Modules of the Secondary Capture Image IOD.

Table 99: Secondary Capture Image – IOD Modules

IE	Module	Reference	Presence of Module
Patient	Patient	Table 75	ALWAYS
Study	General Study	Table 76	ALWAYS
	Patient Study	Table 77	ALWAYS
Series	General Series	Table 100	ALWAYS
	CSA Series Header (P)	Table 79	U – when content available
Equipment	General Equipment	Table 101	ALWAYS
	SC Equipment	Table 102	ALWAYS
Acquisition	General Acquisition	N/A	M = Mandatory but contains only Type 3 attributes. None of them are used.
Image	General Image	Table 103	ALWAYS
	Image Pixel	Table 104	ALWAYS
	SC Image	Table 105	ALWAYS
	Overlay Plane	Table 106	ALWAYS
	Modality LUT	Table 107 : Modality LUT Module Attributes – SC Image	Present for “PET Statistics” Missing for “CT Patient Protocol”
	VOI LUT	Table 108 : VOI LUT Module Attributes – SC Image	ALWAYS
	SOP Common	Table 109: SOP Common Module Attributes – SC Image	ALWAYS
	CSA Image Header (P)	Table 78	U – when content available
	MEDCOM Header (P)	Table 80	U – when content available
	MEDCOM OOG (P)	Table 81	U – when content available
syngo Report Data (P)	Table 82	U – when content available	

	Extension attributes – SC Image (P)	Table 110: Extension attributes for Secondary Capture Image IOD	ALWAYS
--	-------------------------------------	---	--------

9.1.1.3.1 Module General Series (SC Image)

Table 100: General Series Module Attributes – SC image

Attribute Name	Tag	VR	Source	Value	Presence	Comments
Modality	(0008,0060)	CS	AUTO	“CT” “PT”	ALWAYS	
Series Instance UID	(0020,000E)	UI	AUTO	1.3.12.2.1107.5.1.4.Device Serial Number.Object Identifier	ALWAYS	
Series Number	(0020,0011)	IS	AUTO	1 - N	ALWAYS	
Series Date	(0008,0021)	DA	AUTO		ALWAYS	Local date when series was created.
Series Time	(0008,0031)	TM	AUTO		ALWAYS	Format: hhmmss.nnnnnn
Series Description	(0008,103E)	LO	AUTO		ALWAYS	Example: “Patient Protocol” “PET Statistics” See Note
Referenced Performed Procedure Step Sequence	(0008,1111)	SQ	MPPS		ANAP	If MPPS; not for “PET Statistics”
>Referenced SOP Class UID	(0008,1150)	UI	MPPS	1.2.840.10008.3.1.2.3.3 = MPPS SOP Class	ALWAYS	
>Referenced SOP Instance UID	(0008,1155)	UI	MPPS		ALWAYS	
Performed Procedure Step ID	(0040,0253)	SH	AUTO		ANAP	Not for “PET Statistics”
Performed Procedure Step Start Date	(0040,0244)	DA	AUTO		ANAP	Not for “PET Statistics”
Performed Procedure Step Start Time	(0040,0245)	TM	AUTO		ANAP	Not for “PET Statistics”

Note:

Series Description “Patient Protocol” = SC contains CT Dose information in OverlayData.

Series Description “PET Statistics” = SC contains PET Statistics as drawing in PixelData and values in OverlayData.

9.1.1.3.2 Module General Equipment (SC Image)

Table 101: General Equipment Module Attributes – SC Image

Attribute Name	Tag	VR	Source	Value	Presence	Comments
Manufacturer	(0008,0070)	LO	AUTO	"SIEMENS" ¹	ALWAYS	
Institution Name	(0008,0080)	LO	CONFIG		ANAP	Not present for PET Statistics
Institution Address	(0008,0081)	ST	CONFIG		ANAP	Not present for PET Statistics
Station Name	(0008,1010)	SH	CONFIG		ANAP	Not present for PET Statistics
Manufacturer's Model Name	(0008,1090)	LO	CONFIG		ANAP	Not present for PET Statistics
Device Serial Number	(0018,1000)	LO	CONFIG		ANAP	Not present for PET Statistics
Software Versions	(0018,1020)	LO	CONFIG		ANAP	Not present for PET Statistics

9.1.1.3.3 Module SC Equipment (SC Image)

Table 102: SC Equipment Module Attributes – SC Image

Attribute Name	Tag	VR	Source	Value	Presence	Comments
Conversion Type	(0008,0064)	LO	AUTO	"WSD" = Workstation "DRW" = Drawing	ALWAYS	Tables as pixel data
Modality	(0008,0060)	CS	AUTO	"CT" "PT"	ALWAYS	
Secondary Capture Device Manufacturer	(0018,1016)	LO	AUTO	"SIEMENS" ²	ANAP	Only present for "PET Statistics"

9.1.1.3.4 Module General Image (SC Image)

Table 103: General Image Module Attributes – SC Image

Attribute Name	Tag	VR	Source	Value	Presence	Comments
Instance Number	(0020,0013)	IS	AUTO	"2000" = Count Rate Statistics "2002" = Recon Parameters	ALWAYS	Pseudo Instance Number
Patient Orientation	(0020,0020)	CS	AUTO		VNAP	Only when sensible value defined
Content Date	(0008,0023)	DA	AUTO		ALWAYS	Local date when content was created

¹ Might be replaced by "Siemens Healthineers" in future versions² Might be replaced by "Siemens Healthineers" in future versions

Content Time	(0008,0033)	TM	AUTO		ALWAYS	Format: hhmss.nnnnn
Image Type	(0008,0008)	CS	AUTO		ALWAYS	See Section 9.5.1.1.1 for further explanation.
Image Comments	(0020,4000)	LT	AUTO, USER	“PET Count Rate Statistics” “PET PET NAC Reconstruction Parameters” “PET PET AC Reconstruction Parameters”	ANAP	Not present for “Patient Statistics” user can change

9.1.1.3.5 Module Image Pixel (SC Image)

Table 104: Image Pixel Module Attributes – SC Image

Attribute Name	Tag	VR	Source	Value	Presence	Comments
Samples per Pixel	(0028,0002)	US	AUTO	1	ALWAYS	
Photometric Interpretation	(0028,0004)	CS	AUTO	“MONOCHROME2”	ALWAYS	
Rows	(0028,0010)	US	AUTO	“512”	ALWAYS	
Columns	(0028,0011)	US	AUTO	“512”	ALWAYS	
Bits Allocated	(0028,0100)	US	AUTO	“16”	ALWAYS	
Bits Stored	(0028,0101)	US	AUTO	“12”	ALWAYS	
High Bit	(0028,0102)	US	AUTO	“11”	ALWAYS	
Pixel Representation	(0028,0103)	US	AUTO	“0” =unsigned integer	ALWAYS	
Pixel Data	(7FE0,0010)	OW	AUTO		ALWAYS	See Note

Note:

“Patient Protocol” = SC contains CT Dose information in OverlayData. PixelData is has “black” pixels only.
 “PET Statistics” = SC contains PET Statistics and ECG as drawing in PixelData, and parameters in OverlayData

9.1.1.3.6 Module SC Image (SC Image)

Table 105: SC Image Module Attributes – SC Image

Attribute Name	Tag	VR	Source	Value	Presence	Comments
Date of Secondary Capture	(0018,1012)	DA	AUTO		ALWAYS	Local date when content was created
Time of Secondary Capture	(0018,1014)	TM	AUTO		ALWAYS	Format: hhmss.nnnnn

9.1.1.3.7 Module Overlay Plane (SC Image)

The Overlay Plane Module is usually placed in the (6000,eeee) group.

Table 106: Overlay Plane Module Attributes – SC Image

Attribute Name	Tag	VR	Source	Value	Presence	Comments
Overlay Rows	(6000,0010)	US	AUTO	"512"	ALWAYS	
Overlay Columns	(6000,0011)	US	AUTO	"512"	ALWAYS	
Overlay Type	(6000,0040)	CS	AUTO	"G" = Graphics	ALWAYS	
Overlay Origin	(6000,0050)	SS	AUTO	"1\1"	ALWAYS	
Overlay Bits Allocated	(6000,0100)	US	AUTO	"1"	ALWAYS	
Overlay Bit Position	(6000,0102)	US	AUTO	"0"	ALWAYS	
Overlay Data	(6000,3000)	OW	AUTO		ALWAYS	See Note
Overlay Description	(6000,0022)	LO	AUTO	"Siemens MedCom Object Graphics"	ALWAYS	

Note:

"Patient Protocol" = SC contains CT Dose information in OverlayData.

"PET Statistics" = SC contains PET Statistics as drawing and ECG in PixelData, and parameters in OverlayData.

9.1.1.3.8 Module Modality LUT – SC Image

Table 107 : Modality LUT Module Attributes – SC Image

Attribute Name	Tag	VR	Source	Value	Presence	Comments
Rescale Intercept	(0028,1052)	DS	AUTO	"0"	ALWAYS	
Rescale Slope	(0028,1053)	DS	AUTO	"1"	ALWAYS	
Rescale Type	(0028,1054)	LO	AUTO	"US"	ALWAYS	

9.1.1.3.9 Module VOI LUT (SC Image)

Table 108 : VOI LUT Module Attributes – SC Image

Attribute Name	Tag	VR	Source	Value	Presence	Comments
Window Center	(0028,1050)	DS	AUTO	CT Pat Protocol: "200" PET Statistics: "2048"	ALWAYS	
Window Width	(0028,1051)	DS	AUTO	CT Pat Protocol: "50" PET Statistics: "512"	ALWAYS	

9.1.1.3.10 Module SOP Common (SC Image)

Table 109: SOP Common Module Attributes – SC Image

Attribute Name	Tag	VR	Source	Value	Presence	Comments
----------------	-----	----	--------	-------	----------	----------

SOP Class UID	(0008,0016)	UI	AUTO	1.2.840.10008.5.1.4.1.1.7 =SecondaryCaptureImageStorage	ALWAYS	
SOP Instance UID	(0008,0018)	UI	AUTO	"1.3.12.2.1107.5.1.4."+UID	ALWAYS	
Specific Character Set	(0008,0005)	CS	CONFIG MWL		ALWAYS	
Instance Number	(0020,0013)	IS	AUTO	"2000" = Count Rate Statistics "2002" = Recon Parameters	ALWAYS	Pseudo Instance Number

9.1.1.3.11 Extension Attributes to SC Image IOD

Table 110: Extension attributes for Secondary Capture Image IOD

Attribute Name	Tag	VR	Source	Value	Presence	Comments
Other Patient IDs (RETIRED)	(0010,1000)	LO	MWL		ANAP	Only if present on MWL
Requesting Physician	(0032,1032)	PN	MWL		ANAP	Only if present on MWL
Requesting Service	(0032,1033)	LO	MWL		ANAP	Only if present on MWL
Requested Procedure Description	(0032,1060)	LO	MWL		ANAP	Only if present on MWL
Requested Procedure Code Sequence	(0032,1064)	LO	MWL		ANAP	Only if present on MWL
>Code Value	(0008,0100)	SH	MWL		ANAP	
>Coding Scheme Designator	(0008,0102)	SH	MWL		ANAP	
>Code Meaning	(0008,0104)	LO	MWL		ANAP	
Number of Frames in Overlay	(60xx,0015)	US	AUTO	"1"	ALWAYS	To be changed
Image Frame Origin	(60xx,0051)	US	AUTO	"1"	ALWAYS	To be changed

Notes:

- The attributes
 - OtherPatientIDs
 - RequestingPhysician
 - RequestingService
 - RequestedProcedureDescription
 - RequestedProcedureCodeSequence
are used due to legacy reasons for existing customers. They may be removed in future versions of our implementation.
- The attributes NumberOfFramesInOverlay and ImageFrameOrigin will be removed in future versions, as they are not needed for IOD Secondary Capture Image, which is not a multi-frame.

9.1.1.4 X-Ray Radiation Dose SR IOD

Biograph Vision creates X-Ray Radiation Dose SRs for the CT examinations performed on the system.

The following table specifies the Modules supported in X-Ray Radiation Dose SR IOD.

Table 111: X-Ray Radiation Dose SR IOD Modules

IE	Module	Reference	Presence of Module
Patient	Patient	Table 75	ALWAYS
Study	General Study	Table 76	ALWAYS
	Patient Study	Table 77	If Type 3 attributes are used
Series	SR Document Series	Table 112: SR Document Series Module – X-Ray Radiation Dose SR Instance	ALWAYS
Equipment	General Equipment	Table 86	ALWAYS
	Enhanced General Equipment	Table 113: Enhanced General Equipment Module – X-Ray Radiation Dose SR Instance	ALWAYS
Document	SR Document General	Table 114: SR Document General Module – X-Ray Radiation Dose SR Instance	ALWAYS
	SR Document Content	Table 115: SR Document Content Module – X-Ray Radiation Dose SR Instance	ALWAYS
	SOP Common	Table 116: SOP Common Module – X-Ray Radiation Dose SR Instance	ALWAYS
	syngo Report Data (P)	Table 82	ALWAYS
	Extension Attributes Radiation Dose SR (P)	Table 117: Extension Attributes for X-Ray Radiation Dose Report SR IOD	ALWAYS

9.1.1.4.1 Module SR Document Series (X-Ray Radiation Dose SR)

Table 112: SR Document Series Module – X-Ray Radiation Dose SR Instance

Attribute Name	Tag	VR	Source	Value	Presence	Comments
Series Date	(0008,0021)	DA	AUTO		ALWAYS	Generated by System
Series Time	(0008,0031)	TM	AUTO		ALWAYS	Generated by System
Modality	(0008,0060)	CS	AUTO	SR	ALWAYS	
Referenced Performed	(0008,1111)	SQ	MPPS	Empty	VNAP	

Attribute Name	Tag	VR	Source	Value	Presence	Comments
Procedure Step Sequence						
Series Description	(0008,103E)	LO	AUTO	Dose Report	ALWAYS	
Series Instance UID	(0020,000E)	UI	AUTO		ALWAYS	Generated by System
Series Number	(0020,0011)	IS	AUTO		ALWAYS	Generated by System

9.1.1.4.2 Module Enhanced General Equipment (X-Ray Radiation Dose SR)

Table 113: Enhanced General Equipment Module – X-Ray Radiation Dose SR Instance

Attribute Name	Tag	VR	Source	Value	Presence	Comments
Manufacturer	(0008,0070)	LO	AUTO	"SIEMENS" ¹	ALWAYS	
Manufacturer's Model Name	(0008,1090)	LO	AUTO	One of the following based on system type: "Biograph20_Vision 3R" "Biograph20_Vision 4R" "Biograph40_Vision 3R" "Biograph40_Vision 4R" "Biograph64_Vision 3R" "Biograph64_Vision 4R" "Biograph128_Vision 3R" "Biograph128_Vision 4R" "Biograph128_Vision 3R Edge" "Biograph128_Vision 4R Edge"	ALWAYS	
Device Serial Number	(0018,1000)	LO	CONFIG		ALWAYS	
Software Versions	(0018,1020)	LO	AUTO	"VG85A"	ALWAYS	

9.1.1.4.3 Module SR Document General (X-Ray Radiation Dose SR)

Table 114: SR Document General Module – X-Ray Radiation Dose SR Instance

Attribute Name	Tag	VR	Source	Value	Presence	Comments
Instance Number	(0020,0013)	IS	AUTO		ALWAYS	Generated by System
Content Date	(0008,0023)	DA	AUTO		ALWAYS	Content Date is set to the real-world date when the dose report is generated.
Content Time	(0008,0033)	TM	AUTO		ALWAYS	Content Time is set to the real-world time when the dose report is generated.

¹ Might be replaced by "Siemens Healthineers" in future versions

Performed Procedure Code Sequence	(0040,A372)	SQ	AUTO	Empty	ALWAYS	
Completion Flag	(0040,A491)	CS	AUTO	COMPLETE	ALWAYS	
Verification Flag	(0040,A493)	CS	AUTO	UNVERIFIED	ALWAYS	

9.1.1.4.4 Module SR Document Content (X-Ray Radiation Dose SR)

Table 115: SR Document Content Module – X-Ray Radiation Dose SR Instance

Attribute Name	Tag	VR	Source	Value	Presence	Comments
Value Type	(0040,A040)	CS	AUTO	CONTAINER	ALWAYS	
Concept Name Code Sequence	(0040,A043)	SQ	AUTO		ALWAYS	
>Code Value	(0008,0100)	SH	FIXED	113701	ALWAYS	
>Coding Scheme Designator	(0008,0102)	SH	FIXED	DCM	ALWAYS	
>Code Meaning	(0008,0104)	LO	FIXED	X-Ray Radiation Dose Report	ALWAYS	
Continuity of Content	(0040,A050)	CS	AUTO	SEPARATE	ALWAYS	
Content Template Sequence	(0040,A504)	SQ	AUTO		ALWAYS	
>Mapping Resource	(0008,0105)	CS	AUTO	DCMR	ALWAYS	
>Template Identifier	(0040,DB00)	CS	AUTO	TID 10011	ALWAYS	
Content Sequence	(0040,A730)	SQ	AUTO		ALWAYS	Refer to section 9.3.2.1

9.1.1.4.5 Module SOP Common (X-Ray Radiation Dose SR)

Table 116: SOP Common Module – X-Ray Radiation Dose SR Instance

Attribute Name	Tag	VR	Source	Value	Presence	Comments
SOP Class UID	(0008,0016)	UI	AUTO	1.2.840.10008.5.1.4.1.1.88.67	ALWAYS	
SOP Instance UID	(0008,0018)	UI	AUTO		ALWAYS	Generated by System
Specific Character Set	(0008,0005)	CS	AUTO	ISO_IR 100	ALWAYS	

9.1.1.4.6 Extension Attributes to X-Ray Radiation Dose SR IOD

Table 117: Extension Attributes for X-Ray Radiation Dose Report SR IOD

Attribute Name	Tag	VR	Source	Value	Presence	Comments
SIEMENS CSA REPORT (0029,10xx)						

syngo Report Type	(0029,1008)	CS	AUTO	CTDOSEREPORT	ALWAYS	
syngo Report Version	(0029,1009)	LO	AUTO	1.0	ALWAYS	
SR Variant	(0029,1015)	US	AUTO	6	ALWAYS	
SC SOP Instance UID	(0029,1017)	UI	AUTO		ALWAYS	DICOM SOP Instance UID of syngo based SC image representing the syngo report object. This UID is used to identify the resulting SC object after SR to SC conversion.

9.1.1.5 Radiopharmaceutical Radiation Dose SR IOD

Biograph Vision creates Radiopharmaceutical Radiation Dose SRs for the PET examinations performed on the system.

The following table specifies the Modules supported in Radiopharmaceutical Radiation Dose SR IOD.

Table 118: Radiopharmaceutical Radiation Dose SR IOD Modules

IE	Module	Reference	Presence of Module
Patient	Patient	Table 75	ALWAYS
Study	General Study	Table 76	ALWAYS
	Patient Study	Table 77	If Type 3 attributes are used
Series	SR Document Series	Table 119	ALWAYS
Equipment	General Equipment	Table 86	ALWAYS
	Enhanced General Equipment	Table 120	ALWAYS
Document	SR Document General	Table 121	ALWAYS
	SR Document Content	Table 122	ALWAYS
	SOP Common	Table 123	ALWAYS
	syngo Report Data (P)	Table 82	ALWAYS
	Extension Attributes Radiation Dose SR (P)	Table 124	ALWAYS

9.1.1.5.1 Module SR Document Series (Radiopharmaceutical Radiation Dose SR)

Table 119: SR Document Series Module – Radiopharmaceutical Radiation Dose SR Instance

Attribute Name	Tag	VR	Source	Value	Presence	Comments
Series Date	(0008,0021)	DA	AUTO		ALWAYS	Generated by System
Series Time	(0008,0031)	TM	AUTO		ALWAYS	Generated by System
Modality	(0008,0060)	CS	AUTO	SR	ALWAYS	
Referenced Performed	(0008,1111)	SQ	MPPS	Empty	VNAP	

Attribute Name	Tag	VR	Source	Value	Presence	Comments
Procedure Step Sequence						
Series Description	(0008,103E)	LO	AUTO	PET Dose Report SR	ALWAYS	
Series Instance UID	(0020,000E)	UI	AUTO		ALWAYS	Generated by System
Series Number	(0020,0011)	IS	AUTO		ALWAYS	Generated by System

9.1.1.5.2 Module Enhanced General Equipment (Radiopharmaceutical Radiation Dose SR)

Table 120: Enhanced General Equipment Module – Radiopharmaceutical Radiation Dose SR Instance

Attribute Name	Tag	VR	Source	Value	Presence	Comments
Manufacturer	(0008,0070)	LO	AUTO	"SIEMENS" ¹	ALWAYS	
Manufacturer's Model Name	(0008,1090)	LO	AUTO	One of the following based on system type: "Biograph20_Vision 3R" "Biograph20_Vision 4R" "Biograph40_Vision 3R" "Biograph40_Vision 4R" "Biograph64_Vision 3R" "Biograph64_Vision 4R" "Biograph128_Vision 3R" "Biograph128_Vision 4R" "Biograph128_Vision 3R Edge" "Biograph128_Vision 4R Edge"	ALWAYS	
Device Serial Number	(0018,1000)	LO	CONFIG		ALWAYS	
Software Versions	(0018,1020)	LO	AUTO	"VG85A"	ALWAYS	

9.1.1.5.3 Module SR Document General (Radiopharmaceutical Radiation Dose SR)

Table 121: SR Document General Module – Radiopharmaceutical Radiation Dose SR Instance

Attribute Name	Tag	VR	Source	Value	Presence	Comments
Instance Number	(0020,0013)	IS	AUTO		ALWAYS	Generated by System
Content Date	(0008,0023)	DA	AUTO		ALWAYS	Content Date is set to the real-world date when the dose report is generated.
Content Time	(0008,0033)	TM	AUTO		ALWAYS	Content Time is set to the real-world time when the dose report is generated.

¹ Might be replaced by "Siemens Healthineers" in future versions

Performed Procedure Code Sequence	(0040,A372)	SQ	AUTO	Empty	ALWAYS	
Completion Flag	(0040,A491)	CS	AUTO	COMPLETE	ALWAYS	
Verification Flag	(0040,A493)	CS	AUTO	UNVERIFIED	ALWAYS	

9.1.1.5.4 Module SR Document Content (Radiopharmaceutical Radiation Dose SR)

Table 122: SR Document Content Module – Radiopharmaceutical Radiation Dose SR Instance

Attribute Name	Tag	VR	Source	Value	Presence	Comments
Value Type	(0040,A040)	CS	AUTO	CONTAINER	ALWAYS	
Concept Name Code Sequence	(0040,A043)	SQ	AUTO		ALWAYS	
>Code Value	(0008,0100)	SH	FIXED	113500	ALWAYS	
>Coding Scheme Designator	(0008,0102)	SH	FIXED	DCM	ALWAYS	
>Code Meaning	(0008,0104)	LO	FIXED	Radiopharmaceutical Radiation Dose Report	ALWAYS	
Continuity of Content	(0040,A050)	CS	AUTO	SEPARATE	ALWAYS	
Content Template Sequence	(0040,A504)	SQ	AUTO		ALWAYS	
>Mapping Resource	(0008,0105)	CS	AUTO	DCMR	ALWAYS	
>Template Identifier	(0040,DB00)	CS	AUTO	TID 10021	ALWAYS	
Content Sequence	(0040,A730)	SQ	AUTO		ALWAYS	Refer to section 9.3.2.2.1

9.1.1.5.5 Module SOP Common (Radiopharmaceutical Radiation Dose SR)

Table 123: SOP Common Module – Radiopharmaceutical Radiation Dose SR Instance

Attribute Name	Tag	VR	Source	Value	Presence	Comments
SOP Class UID	(0008,0016)	UI	AUTO	1.2.840.10008.5.1.4.1.1.88.68	ALWAYS	
SOP Instance UID	(0008,0018)	UI	AUTO		ALWAYS	Generated by System
Specific Character Set	(0008,0005)	CS	AUTO	ISO_IR 100	ALWAYS	

9.1.1.5.6 Extension Attributes to Radiopharmaceutical Radiation Dose SR

Table 124: Extension Attributes for Radiopharmaceutical Radiation Dose Report SR IOD

Attribute Name	Tag	VR	Source	Value	Presence	Comments
SIEMENS CSA REPORT (0029,10xx)						
syngo Report Type	(0029,1008)	CS	AUTO	NMDOSEREPORT	ALWAYS	

syngo Report Version	(0029,1009)	LO	AUTO	1.0	ALWAYS	
SR Variant	(0029,1015)	US	AUTO	8	ALWAYS	
SC SOP Instance UID	(0029,1017)	UI	AUTO		ALWAYS	DICOM SOP Instance UID of syngo based SC image representing the syngo report object. This UID is used to identify the resulting SC object after SR to SC conversion.

9.1.1.6 Comprehensive SR IOD

Biograph Vision creates Comprehensive SRs for the CT Postprocessing Applications CalciumScoring / LungCare / Oncology / Circulation on the system.

The following table specifies the Modules supported in Comprehensive SR IODs.

Table 125: Comprehensive SR IOD Modules

IE	Module	Reference	Presence of Module
Patient	Patient	Table 75	ALWAYS
Study	General Study	Table 76	ALWAYS
	Patient Study	Table 77	If Type 3 attributes are used
Series	SR Document Series	Table 126: SR Document Series Module – Comprehensive SR Instance	ALWAYS
Equipment	General Equipment	Table 86	ALWAYS
SR Document	SR Document General	Table 127: SR Document General Module – Comprehensive SR Instance	ALWAYS
	SR Document Content	Table 128: SR Document Content Module – Comprehensive SR Instance	ALWAYS
	SOP Common	Table 129: SOP Common Module – Comprehensive SR Instance	ALWAYS
	syngo Report Data (P)	Table 82	ALWAYS
	Extension Attributes (P)	Table 130	ALWAYS

9.1.1.6.1 Module SR Document Series (Comprehensive SR)

Table 126: SR Document Series Module – Comprehensive SR Instance

Attribute Name	Tag	VR	Source	Value	Presence	Comments
Series Date	(0008,0021)	DA	AUTO		ALWAYS	Generated by System
Series Time	(0008,0031)	TM	AUTO		ALWAYS	Generated by System
Modality	(0008,0060)	CS	AUTO	SR	ALWAYS	
Referenced Performed Procedure Step Sequence	(0008,1111)	SQ	MWL/AUTO	Empty	VNAP	
Series Description	(0008,103E)	LO	AUTO		ALWAYS	
Series Instance UID	(0020,000E)	UI	AUTO		ALWAYS	Generated by System
Series Number	(0020,0011)	IS	AUTO		ALWAYS	Generated by System

9.1.1.6.2 Module SR Document General (Comprehensive SR)

Table 127: SR Document General Module – Comprehensive SR Instance

Attribute Name	Tag	VR	Source	Value	Presence	Comments
Instance Number	(0020,0013)	IS	AUTO		ALWAYS	Generated by System
Content Date	(0008,0023)	DA	AUTO		ALWAYS	Image (Content) Date for Comprehensive SR is set to the real-world date when the dose report is generated.
Content Time	(0008,0033)	TM	AUTO		ALWAYS	Image (Content) Time for Comprehensive SR is set to the real-world time when the dose report is generated.
Completion Flag	(0040,A491)	CS	AUTO	COMPLETE or PARTIAL	ALWAYS	
Verification Flag	(0040,A493)	CS	AUTO	UNVERIFIED or VERIFIED	ALWAYS	

9.1.1.6.3 Module SR Document Content (Comprehensive SR)

Table 128: SR Document Content Module – Comprehensive SR Instance

Attribute Name	Tag	VR	Source	Value	Presence	Comments
Value Type	(0040,A040)	CS	AUTO	CONTAINER	ALWAYS	
Continuity of Content	(0040,A050)	CS	AUTO	SEPARATE	ALWAYS	
Content Template Sequence	(0040,A504)	SQ	AUTO		ALWAYS	

>Mapping Resource	(0008,0105)	CS	AUTO	DCMR	ALWAYS	
>Template Identifier	(0040,DB00)	CS	AUTO		ALWAYS	Report specific
Content Sequence	(0040,A730)	SQ	AUTO		ALWAYS	

9.1.1.6.4 Module SOP Common (Comprehensive SR)

Table 129: SOP Common Module – Comprehensive SR Instance

Attribute Name	Tag	VR	Source	Value	Presence	Comments
SOP Class UID	(0008,0016)	UI	AUTO	1.2.840.10008.5.1.4.1.1.88.33 Comprehensive SR Storage	ALWAYS	
SOP Instance UID	(0008,0018)	UI	AUTO		ALWAYS	Generated by System
Specific Character Set	(0008,0005)	CS	CONFIG MWL		ALWAYS	

9.1.1.6.5 Extension Attributes to Comprehensive SR IOD

Table 130: Extension attributes for Comprehensive SR IOD

Attribute Name	Tag	VR	Source	Value	Presence	Comments
Image Type	(0008,0008)	CS	AUTO		ANAP	

Note:

- Please see also 9.5.3.1.2.

9.1.1.7 CSA Non-Image IOD (private)

Table 131: CSA Non-Image IOD Modules

IE	Module	Reference	Presence of Module
Patient	Patient	Table 75	M
Study	General Study	Table 76	M
	Patient Study	Table 77	U
Series	General Series	Table 132: General Series Module Attributes – CSA Non-Image	M
Equipment	General Equipment	Table 133: General Equipment Module Attributes – CSA Non-Image	U
CSA	CSA Image Header	Table 78	U
	CSA Series Header	Table 79	U
	MEDCOM Header	Table 80	U

	CSA Non-Image	Table 135: CSA Non-Image Module	M
	SOP Common	Table 134: SOP Common Module Attributes – CSA Non-Image	M

9.1.1.7.1 Module General Series (CSA Non-Image)

Table 132: General Series Module Attributes – CSA Non-Image

Attribute Name	Tag	VR	Source	Value	Presence	Comments
Modality	(0008,0060)	CS	AUTO	"CT" "PT"	ALWAYS	
Series Instance UID	(0020,000E)	UI	AUTO	1.3.12.2.1107.5.1.4.Device Serial Number.Object Identifier	ALWAYS	
Series Number	(0020,0011)	IS	AUTO	1 - N	ALWAYS	
Series Date	(0008,0021)	DA	AUTO		ALWAYS	Local date when series was created.
Series Time	(0008,0031)	TM	AUTO		ALWAYS	Format: hhmmss.nnnnnn
Series Description	(0008,103E)	LO	AUTO		ALWAYS	
Referenced Performed Procedure Step Sequence	(0008,1111)	SQ	MPPS		ANAP	
>Referenced SOP Class UID	(0008,1150)	UI	MPPS	1.2.840.10008.3.1.2.3.3 = MPPS SOP Class	ALWAYS	
>Referenced SOP Instance UID	(0008,1155)	UI	MPPS		ALWAYS	
Performed Procedure Step ID	(0040,0253)	DA	AUTO		ANAP	
Performed Procedure Step Start Date	(0040,0244)	DA	AUTO		ANAP	
Performed Procedure Step Start Time	(0040,0245)	TM	AUTO		ANAP	

9.1.1.7.2 Module General Equipment (CSA Non-Image)

Table 133: General Equipment Module Attributes – CSA Non-Image

Attribute Name	Tag	VR	Source	Value	Presence	Comments
----------------	-----	----	--------	-------	----------	----------

Manufacturer	(0008,0070)	LO	AUTO	“SIEMENS” ¹	ALWAYS	
Institution Name	(0008,0080)	LO	CONFIG		ANAP	
Institution Address	(0008,0081)	ST	CONFIG		ANAP	
Station Name	(0008,1010)	SH	CONFIG		ANAP	
Manufacturer's Model Name	(0008,1090)	LO	CONFIG		ANAP	
Device Serial Number	(0018,1000)	LO	CONFIG		ANAP	
Software Versions	(0018,1020)	LO	CONFIG		ANAP	

9.1.1.7.3 Module SOP Common (CSA Non-Image)

Table 134: SOP Common Module Attributes – CSA Non-Image

Attribute Name	Tag	VR	Source	Value	Presence	Comments
SOP Class UID	(0008,0016)	UI	AUTO	1.3.12.2.1107.5.9.1=CsaNonImageStorage	ALWAYS	
SOP Instance UID	(0008,0018)	UI	AUTO	“1.3.12.2.1107.5.1.4.”+UID	ALWAYS	
Specific Character Set	(0008,0005)	CS	CONFIG MWL		ALWAYS	
Instance Number	(0020,0013)	IS	AUTO	1 – N	ALWAYS	

9.1.1.7.4 CSA Non-Image Module

The table in this section contains private Attributes that are supported in the CSA Non-Image Module.

Table 135: CSA Non-Image Module

Attribute Name	Tag	Private Creator Identifier	VR	Source	Value	Presence	Comments
Image Type	(0008,0008)	-	CS	AUTO		ANAP	See Section 9.5.1.1.1 (Image Type) for further explanation.
Acquisition Date	(0008,0022)	-	DA	AUTO		ANAP	The date the acquisition of data that resulted in this data set started.
Acquisition Time	(0008,0032)	-	TM	AUTO		ANAP	The time the acquisition of data

¹ Might be replaced by “Siemens Healthineers” in future versions

Attribute Name	Tag	Private Creator Identifier	VR	Source	Value	Presence	Comments
							that resulted in this data set started.
Conversion Type	(0008,0064)	-	CS	AUTO	DV DI DF WSD	ANAP	Describes the kind of image conversion. Defined Terms: DV = Digitized Video, DI = Digital Interface, DF = Digitized Film, WSD = Workstation.
Referenced Image Sequence	(0008,1140)	-	SQ	AUTO		ANAP	A sequence which provides reference to a set of Image SOP Class/Instance identifying other images significantly related to this data set.
>Referenced SOP Class UID	(0008,1150)	-	UI	AUTO		ANAP	Uniquely identifies the referenced SOP Class.
>Referenced SOP Instance UID	(0008,1155)	-	UI	AUTO		ANAP	Uniquely identifies the referenced SOP Instance.
Derivation Description	(0008,2111)	-	ST	AUTO		ANAP	A text description of how this data set was derived.
Source Image Sequence	(0008,2112)	-	SQ	AUTO		ANAP	A Sequence which identifies the set of Image SOP Class/Instance pairs of the Images which were used to derive this data set. Zero or more Items may be included in this Sequence.

Attribute Name	Tag	Private Creator Identifier	VR	Source	Value	Presence	Comments
>Referenced SOP Class UID	(0008,1150)	-	UI	AUTO		ANAP	Uniquely identifies the referenced SOP Class.
>Referenced SOP Instance UID	(0008,1155)	-	UI	AUTO		ANAP	Uniquely identifies the referenced SOP Instance.
Patient Position	(0018,5100)	-	CS	AUTO		ANAP	Patient position descriptor relative to the equipment.
Acquisition Number	(0020,0012)	-	IS	AUTO		ANAP	A number identifying the gathering of data over a period of time which resulted in this data set.
Instance Number	(0020,0013)	-	IS	AUTO		ANAP	A number that identifies this data set.
Frame of Reference UID	(0020,0052)	-	UI	AUTO		ANAP	Uniquely identifies the frame of reference for a Series.
Image Comments	(0020,4000)	-	LT	AUTO		ANAP	User-defined comments about the image.
Quality Control Image	(0028,0300)	-	CS	AUTO		ANAP	Indicates whether or not this image is a quality control or phantom image. If this Attribute is absent, then the image may or may not be a quality control or phantom image. Enumerated Values: YES, NO.

Attribute Name	Tag	Private Creator Identifier	VR	Source	Value	Presence	Comments
Burned In Annotation	(0028,0301)	-	CS	AUTO		ANAP	<p>Indicates whether or not image contains sufficient burned in annotation to identify the patient and date the image was acquired.</p> <p>If this Attribute is absent, then the image may or may not contain burned in annotation.</p> <p>Enumerated Values: YES, NO.</p>
Lossy Image Compression	(0028,2110)	-	CS	AUTO		ANAP	<p>Specifies whether an Image has undergone lossy compression.</p> <p>Enumerated Values: 00 = Image has NOT been subjected to lossy compression, 01 = Image has been subjected to lossy compression.</p>
Lossy Image Compression Ratio	(0028,2112)	-	DS	AUTO		ANAP	<p>Describes the approximate lossy compression ratio(s) that have been applied to this image.</p> <p>May be multi valued if successive lossy compression steps have been applied.</p>
CSA Data Type	(0029,xx08)	SIEMENS CSA NON- IMAGE	CS	AUTO		ALWAYS	<p>CSA Data identification characteristics.</p> <p>Defined Terms: RAW DATA NUM 4 = NUMARIS/4 Raw Data SPEC NUM 4 = NUMARIS/4 Spectroscopy RAW DATA SOM 5 = Somaris/5 Raw Data RAW DATA SOM 7 = Somaris/7 Raw Data</p>

Attribute Name	Tag	Private Creator Identifier	VR	Source	Value	Presence	Comments
							BSR REPORT = BSR Study Report Data COL REPORT SOM5 = syngo Colonography Report Data
CSA Data Version	(0029,xx09)	SIEMENS CSA NON-IMAGE	LO	AUTO		ANAP	Version of CSA Data Info (0029,xx10) format and CSA Non-Image Data (7FE1,xx10) format.
CSA Data Info	(0029,xx10)	SIEMENS CSA NON-IMAGE	OB	AUTO		ANAP	Information to describe the CSA Data (7FE1,xx10). The value of the attribute CSA Data Info (0029,xx10) can be build up in each user defined format.
CSA Data	(7FE1,xx10)	SIEMENS CSA NON-IMAGE	OB	AUTO		ALWAYS	Binary data as byte stream.

9.1.1.8 Positron Emission Tomography Image IOD

The following table specifies the Modules supported in the PET Image IOD.

Table 136: PET Image IOD Modules

IE	Module	Reference	Presence of Module
Patient	Patient	Table 137: Patient Module	ALWAYS
Study	General Study	Table 138: General Study Module	ALWAYS
	Patient Study	Table 139: Patient Study Module	ALWAYS
Series	General Series	Table 140: General Series Module	ALWAYS
	PET Series	Table 141: PET Series Module	ALWAYS
	PET Isotope	Table 142: PET Isotope Module	ALWAYS

IE	Module	Reference	Presence of Module
	PET Multi-gated Acquisition	Table 143: PET Multi-gated Acquisition Module	Only for Gated
	PET/NM Patient Orientation	Table 144: NM/PET Patient Orientation Module	ALWAYS
Frame of Reference	Frame of Reference	Table 145: Frame of Reference Module	ALWAYS
Equipment	General Equipment	Table 146: General Equipment Module	ALWAYS
Acquisition	General Acquisition	Table 147: General Acquisition Module	ALWAYS
Image	General Image	Table 148: General Image Module	ALWAYS
	Image Plane	Table 149: Image Plane Module	ALWAYS
	Image Pixel	Table 150: Image Pixel Module	ALWAYS
	PET Image	Table 151: PET Image Module	ALWAYS
	VOI LUT	Table 152: VOI LUT Module	ALWAYS
	Acquisition Context	Table 153: Acquisition Context	ALWAYS
	SOP Common	Table 154: SOP Common	ALWAYS
Private	Private Attributes	Error! Reference source not found.	ALWAYS
Extensions	Standard Extended Attributes	Table 190	ALWAYS

The following tables describe attribute interpretations for PET images including MU maps. MU maps are encoded in PET IOD.

9.1.1.8.1 Module Patient (PET Image)

Table 137: Patient Module – PET Image

Attribute Name	Tag	VR	Source	Value	Presence	Comments
Patient's Name	(0010,0010)	PN	MWL/USER		ALWAYS	Input from MWL or entered during patient registration or examination setup.
Patient ID	(0010,0020)	LO	MWL/USER		ALWAYS	Input from MWL or entered or generated during patient registration or examination setup.
Issuer of Patient ID	(0010,0021)	LO	MWL		ANAP	Input from MWL
Patient's Birth Date	(0010,0030)	LO	MWL/USER/AUTO		ALWAYS	Input from MWL or entered during patient registration or examination setup. May be calculated from age.
Patient's Birth Time	(0010,0032)	TM	MWL/USER		ANAP	Input from MWL or entered during patient registration or examination setup.
Patient's Sex	(0010,0040)	CS	MWL/USER		ALWAYS	Input from MWL or entered during patient registration or examination setup.

9.1.1.8.2 Module General Study (PET Image)

Table 138: General Study Module– PET Image

Attribute Name	Tag	VR	Source	Value	Presence	Comments
Study Date	(0008,0020)	DA	AUTO		ALWAYS	For existing studies their date and time entries are copied into the corresponding entries in a new image's header. If a new study is created the date and time entries from the first series of this new study will be used.
Study Time	(0008,0030)	TM	AUTO		ALWAYS	See above
Accession Number	(0008,0050)	SH	MWL/USER		VNAP	Input entered from MWL or during patient registration.
Referring Physician's Name	(0008,0090)	PN	MWL/USER		VNAP	Input from MWL or entered during patient registration or examination setup.
Study Description	(0008,1030)	LO	MWL/USER		ALWAYS	Input from MWL or is derived from information entered during patient registration or examination setup. Concatenated from Body Region and selected Scan Protocol name, separated by a "^".
Study Instance UID	(0020,000D)	UI	MWL/AUTO		ALWAYS	From MWL or created
Study ID	(0020,0010)	SH	MWL/AUTO		ALWAYS	From MWL or created

9.1.1.8.3 Module Patient Study (PET Image)

Table 139: Patient Study Module– PET Image

Attribute Name	Tag	VR	Source	Value	Presence	Comments
Admitting Diagnoses Description	(0008,1080)	LO	MWL/USER		VNAP	Input entered from MWL or during patient registration.
Patient's Age	(0010,1010)	AS	MWL/USER/AUTO		ALWAYS	Input from MWL or entered during patient registration or examination setup. May be calculated from Patient's Birth Date
Patient's Weight	(0010,1030)	DS	MWL/USER		ALWAYS	Input from MWL or entered during patient registration or examination setup. Set to 0 for emergency patients.

9.1.1.8.4 Module General Series (PET Image)

Table 140: General Series Module– PET Image

Attribute Name	Tag	VR	Source	Value	Presence	Comments
Modality	(0008,0060)	CS	AUTO	PT	ALWAYS	
Performing Physician's Name	(0008,1050)	PN	MWL/USER		VNAP	Input entered from MWL or during patient registration.
Operators' Name	(0008,1070)	PN	USER		VNAP	According to user input.
Series Description	(0008,103E)	LO	USER/CONFIG		ALWAYS	Based on user input and configured suffix. Limited to 64 characters
Related Series Sequence	(0008,1250)	SQ	AUTO		ANAP	Reference to CT series used for attenuation correction Not filled for mu maps
>Study Instance UID	(0020,000D)	UI	AUTO		ANAP	Instance UID of study to which the related CT series belongs
>Series Instance UID	(0020,000E)	UI	AUTO		ANAP	Instance UID of related CT series
>Purpose of Reference Code Sequence	(0040,A170)	SQ	AUTO		ANAP	Describes the purpose for which the reference is made. Zero or more items may be present. When absent, implies that the reason for the reference is unknown. See 9.3.1.1 for supported purposes.
>>Code Value	(0008,0100)	SH	AUTO		ANAP	
>>Coding Scheme Designator	(0008,0102)	SH	AUTO		ANAP	
>>Code Meaning	(0008,0104)	LO	AUTO		ANAP	
Body Part Examined	(0018,0015)	CS	USER		ALWAYS	The Body Part Examined is directly entered by the operator.
Protocol Name	(0018,1030)	LO	AUTO		ALWAYS	Name of Scan Protocol selected during patient registration or examination setup
Patient Position	(0018,5100)	CS	USER		ALWAYS	As entered for scan. This value is set despite the use of the Patient Orientation Code Sequence (0054, 0410).
Series Instance UID	(0020,000E)	UI	AUTO		ALWAYS	Created
Series Number	(0020,0011)	IS	AUTO		ALWAYS	Created

9.1.1.8.5 Module PET Series (PET Image)

Table 141: PET Series Module– PET Image

Attribute Name	Tag	VR	Source	Value	Presence	Comments
Series Date	(0008,0021)	DA	AUTO		ALWAYS	The DATE to which images in this Series were decay corrected.
Series Time	(0008,0031)	TM	AUTO		ALWAYS	The TIME to which images in this Series were decay corrected.
Collimator Type	(0018,1181)	CS	AUTO	NONE	ALWAYS	
Convolution Kernel	(0018,1210)	SH	AUTO	Filter type and parameters: XYZ Gauss<w> XYZ Hamm<w> XYZ Hann<w> XYZ Parz<w> XYZ BUTW<w>-<o> XYZ SHEP<w> XYZ BOX	ALWAYS	where <w> is the filter width (fwhm), and <o> is the filter order e.g. XYZ BUTW5.00-1
Corrected Image	(0028,0051)	CS	AUTO	DECY, ATTN, SCAT, DTIM, RAN, NORM, RADL, PGC, RESPMOT for OncoFreeze Images, CARDIOMOT for CardioFreezeSingle Images, CARDIOMOT\RESPMOT for CardioFreezeDual Images, Blank for mu maps	VNAP	
Energy Window Range Sequence	(0054,0013)	SQ	AUTO		ALWAYS	Sequence containing one item describing the energy window used to acquire the PET image series.
>Energy Window Lower Limit	(0054,0014)	DS	AUTO		ALWAYS	The lower limit of the energy window in keV.
>Energy Window Upper Limit	(0054,0015)	DS	AUTO		ALWAYS	The upper limit of the energy window in keV.
Number of R-R Intervals	(0054,0061)	US	AUTO	1	ANAP	For gated only
Number of Time Slots	(0054,0071)	US	AUTO		ANAP	Number of gates, for gated only
Number of Slices	(0054,0081)	US	AUTO		ALWAYS	If PET slice location is configured to match CT slice location, this number is determined by the available number of CT slices within the PET scan range. Otherwise, it is calculated based on bed positions or number of

Attribute Name	Tag	VR	Source	Value	Presence	Comments
						gates/frames, number of detector rings and overlap.
Number of Time Slices	(0054,0101)	US	AUTO		ANAP	Number of frames, for dynamic only
Series Type	(0054,1000)	CS	AUTO	WHOLE BODY, DYNAMIC or GATED IMAGE	ALWAYS	
Units	(0054,1001)	CS	AUTO	BQML for quantitative, attenuation corrected images PROPCPS for non-quantitative, non-attenuation corrected images 1CM for mu maps PCT for PET Patlak Intercept Image MGMINML or UMOLMINML or MLMINML for PET Patlak Slope Image	ALWAYS	
Counts Source	(0054,1002)	CS	AUTO	EMISSION for PET images TRANSMISSION for mu maps	ALWAYS	The primary source of counts.
Randoms Correction Method	(0054,1100)	CS	AUTO	DLYD	ALWAYS	
Attenuation Correction Method	(0054,1101)	LO	AUTO	For attenuation corrected PET images: measured, name of used CT Series, calculated, CBAC (=Calculated Brain AC) For mu maps: measured, calculated	ANAP	
Decay Correction	(0054,1102)	CS	AUTO	START or ADMIN. START= acquisition start time ADMIN = radiopharmaceutical administration time This refers to the Series Date and Time, see (0008,0021) and (0008,0031) and private attribute (0071,1022) NONE for mu maps	ALWAYS	The real-world event to which images in this Series were decay corrected.
Reconstruction Method	(0054,1103)	LO	AUTO	Backprojection Backprojection+TOF OSEM2D <m>i<n>s OSEM3D <m>i<n>s OSEM3D+TOF <m>i<n>s PSF <m>i<n>s PSF+TOF <m>i<n>s Patlak	ALWAYS	e.g. OSEM3D 2i8s. WB prefix is added in case WB scatter scaling is used.

Attribute Name	Tag	VR	Source	Value	Presence	Comments
				WB OSEM2D <m>i<n>s WB OSEM3D <m>i<n>s WB OSEM3D+TOF <m>i<n>s WB PSF <m>i<n>s WB PSF+TOF <m>i<n>s where <m> is the number of iterations and <n> the number of subsets,		
Scatter Correction Method	(0054,1105)	LO	AUTO	Model-based, relative scatter scaling Model-based, absolute scatter scaling Model-based, WB relative scatter scaling Model-based, WB absolute scatter scaling	ANAP	Set if Scatter correction was applied.
Axial Acceptance	(0054,1200)	DS	AUTO		ALWAYS	The maximum detector ring difference instead of angle in degrees.
Axial Mash	(0054,1201)	IS	AUTO		ALWAYS	Number of adjacent axial lines of response mashed together

9.1.1.8.6 Module PET Isotope (PET Image)

Table 142: PET Isotope Module– PET Image

Attribute Name	Tag	VR	Source	Value	Presence	Comments
Radiopharmaceutical Information Sequence	(0054,0016)	SQ	AUTO		ALWAYS	Sequence containing items describing the isotope information. Blank for mu maps
>Radiopharmaceutical Volume	(0018,1071)	DS	AUTO		ALWAYS	Volume of administered radiopharmaceutical in cubic cm.
>Radiopharmaceutical Start Time	(0018,1072)	TM	AUTO		ALWAYS	Time of start of injection (Since there is no attribute for the injection date, a day shift between start of injection and start of acquisition is encoded in the last 3 digits of the injection time, ensuring compatibility with earlier systems.)
>Radionuclide Total Dose	(0018,1074)	DS	AUTO		ALWAYS	The radiopharmaceutical dose administered to the patient measured in Becquerel (Bq) at the

Attribute Name	Tag	VR	Source	Value	Presence	Comments
						Radiopharmaceutical Start Time
>Radiopharmaceutical Administration Event UID	(0008,3012)	UI	AUTO		ALWAYS	Unique identification of the administration of the radiopharmaceutical to the patient. Note: The UID is the same Radiopharmaceutical Administration Event UID that is in the Radiopharmaceutical Radiation Dose Report.
>Radionuclide Half Life	(0018,1075)	DS	AUTO		ALWAYS	The radionuclide half-life, in seconds, that was used in the correction of this image.
>Radionuclide Positron Fraction	(0018,1076)	DS	AUTO		ALWAYS	The radionuclide positron fraction (fraction of decays that are by positron emission) that was used in the correction of this image, e.g., 0.97 for 18F.
>Radiopharmaceutical Start DateTime	(0018,1078)	DT	AUTO		ALWAYS	Date and time of start of administration. The actual date and time of radiopharmaceutical administration to the patient for imaging purposes, using the same time base as Series Time (0008, 0031).
>Radiopharmaceutical Stop DateTime	(0018,1079)	DT	AUTO		ALWAYS	Date and time of end of administration. The actual ending date and time of radiopharmaceutical administration to the patient for imaging purposes, using the same time base as Series Time (0008,0031).
>Radionuclide Code Sequence	(0054,0300)	SQ	AUTO		ALWAYS	Sequence that identifies the radionuclide. Only present for radionuclides defined in Table 171: Supported Radionuclides for Created PET Images
>>Code Value	(0008,0100)	SH	AUTO		ALWAYS	See Table 171: Supported Radionuclides for Created PET Images
>>Coding Scheme Designator	(0008,0102)	SH	AUTO		ALWAYS	See Table 171: Supported Radionuclides for Created PET Images

Attribute Name	Tag	VR	Source	Value	Presence	Comments
>>Code Meaning	(0008,0104)	LO	AUTO		ALWAYS	See Table 171: Supported Radionuclides for Created PET Images
>Radiopharmaceutical	(0018,0031)	LO	AUTO		ALWAYS	Name of the radiopharmaceutical
>Radiopharmaceutical Code Sequence	(0054,0304)	SQ	AUTO		ALWAYS	Sequence that identifies the radiopharmaceutical. Only present for radiopharmaceuticals defined in Table 172: Supported Radiopharmaceuticals for Created PET Images
>>Code Value	(0008,0100)	SH	AUTO		ALWAYS	See Table 172: Supported Radiopharmaceuticals for Created PET Images
>>Coding Scheme Designator	(0008,0102)	SH	AUTO		ALWAYS	See Table 172: Supported Radiopharmaceuticals for Created PET Images
>>Code Meaning	(0008,0104)	LO	AUTO		ALWAYS	See Table 172: Supported Radiopharmaceuticals for Created PET Images

9.1.1.8.7 Module PET Multi-gated Acquisition Module (PET Image)

Table 143: PET Multi-gated Acquisition Module– PET Image

Attribute Name	Tag	VR	Source	Value	Presence	Comments
Cardiac Framing Type	(0018,1064)	LO	AUTO	PHASED	ALWAYS	Gated Only
Beat Rejection Flag	(0018,1080)	CS	AUTO	Y for trigger gating N for respiratory waveform gating	ALWAYS	Gated only.
Skip Beats	(0018,1086)	IS	AUTO		ALWAYS	Number of skipped beats after a detected arrhythmia. Gated only.
Heart Rate	(0018,1088)	IS	AUTO		ALWAYS	Average number of heart beats or respirations per minute for the collection period. This includes all accepted and rejected beats or respirations. Gated only.

9.1.1.8.8 Module NM/PET Patient Orientation (PET Image)

Table 144: NM/PET Patient Orientation Module– PET Image

Attribute Name	Tag	VR	Source	Value	Presence	Comments
Patient Orientation Code	(0054,0410)	SQ	AUTO		ALWAYS	Sequence containing one item that describes the

Attribute Name	Tag	VR	Source	Value	Presence	Comments
Sequence						orientation of the patient with respect to gravity.
>Code Value	(0008,0100)	SH	AUTO	F-10450	ALWAYS	
> Coding Scheme Designator	(0008,0102)	SH	AUTO	99SDM	ALWAYS	
> Code Meaning	(0008,0104)	LO	AUTO	recumbent	ALWAYS	
>Patient Orientation Modifier Code Sequence	(0054,0412)	SQ	USER		ALWAYS	Sequence containing one item that modifies or enhances the orientation specified by Patient Orientation Code Sequence.
>>Code Value	(0008,0100)	SH	AUTO		ALWAYS	
>> Coding Scheme Designator	(0008,0102)	SH	AUTO	99SDM	ALWAYS	
>> Code Meaning	(0008,0104)	LO	AUTO	supine, prone, right lateral decubitus, left lateral decubitus	ALWAYS	
Patient Gantry Relationship Code Sequence	(0054,0414)	SQ	USER		ALWAYS	Sequence containing one item that describes the orientation of the patient with respect to the gantry.
>Code Value	(0008,0100)	SH	AUTO		ALWAYS	
> Coding Scheme Designator	(0008,0102)	SH	AUTO	99SDM	ALWAYS	
> Code Meaning	(0008,0104)	LO	AUTO	head-first, feet-first	ALWAYS	

9.1.1.8.9 Module Frame of Reference (PET Image)

Table 145: Frame of Reference Module– PET Image

Attribute Name	Tag	VR	Source	Value	Presence	Comments
Frame of Reference UID	(0020,0052)	UI	AUTO		ALWAYS	
Position Reference Indicator	(0020,1040)	LO	AUTO		EMPTY	

9.1.1.8.10 Module General Equipment (PET Image)

Table 146: General Equipment Module– PET Image

Attribute Name	Tag	VR	Source	Value	Presence	Comments
Manufacturer	(0008,0070)	LO	AUTO	SIEMENS	ALWAYS	

Attribute Name	Tag	VR	Source	Value	Presence	Comments
Institution Name	(0008,0080)	LO	CONFIG/USER		ALWAYS	Hospital name read from configuration data or user input entered during patient registration or examination setup.
Institution Address	(0008,0081)	ST	CONFIG		ALWAYS	Hospital address read from configuration data. Default format is 4 lines containing Street, City, District and Country.
Station Name	(0008,1010)	SH	CONFIG		ALWAYS	Station name as per site specific configuration.
Institutional Department Name	(0008,1040)	LO	CONFIG		ALWAYS	According to site configuration.
Manufacturer's Model Name	(0008,1090)	LO	AUTO	One of the following based on system type: "Biograph20_Vision 3R" "Biograph20_Vision 4R" "Biograph40_Vision 3R" "Biograph40_Vision 4R" "Biograph64_Vision 3R" "Biograph64_Vision 4R" "Biograph128_Vision 3R" "Biograph128_Vision 4R" "Biograph128_Vision 3R Edge" "Biograph128_Vision 4R Edge"	ALWAYS	
Device Serial Number	(0018,1000)	LO	AUTO		ALWAYS	Serial number of the PET/CT system
Software Version(s)	(0018,1020)	LO	AUTO		ALWAYS	Biograph Vision software version. One or two values. If two values are present, the first value indicates the SW version in which the data were acquired; the second is the SW version in which the data have been reconstructed.
Date of Last Calibration	(0018,1200)	DA	AUTO		ALWAYS	Date of last Gantry Calibration / FOV Offset
Time of Last Calibration	(0018,1201)	TM	AUTO		ALWAYS	Time of last Gantry Calibration / FOV Offset

9.1.1.8.11 Module General Acquisition (PET Image)

Table 147: General Acquisition Module– PET Image

Attribute Name	Tag	VR	Source	Value	Presence	Comments
Acquisition Number	(0020,0012)	IS	AUTO		ALWAYS	A combination of the scan range number within the examination and bed index. For example, for standard whole-body scans (Topo, Spiral CT range, PET range), the acquisition number is set to 2 * 1000 + bed index

9.1.1.8.12 Module General Image (PET Image)

Table 148: General Image Module– PET Image

Attribute Name	Tag	VR	Source	Value	Presence	Comments
Content Date	(0008,0023)	DA	AUTO		ALWAYS	Image (Content) Date for PET images is set to the real-world date when the images are generated.
Content Time	(0008,0033)	TM	AUTO		ALWAYS	Image (Content) Time for PET images is set to the real-world time when the images are generated.
Instance Number	(0020,0013)	IS	AUTO		ALWAYS	
Image Comments	(0020,4000)	LT	AUTO/USER/CONFIG	Concatenated string, separated by "^": <ul style="list-style-type: none"> - User input for comment - Blood Glucose information <BGL:value:units> - Gate definition for gated images - Frame description for dynamic images - Pass information for Summed WB Dynamic - CT series description for attenuation correction - /TF if transformation matrix was applied - /MAR if metal artefact correction was applied - Volume Scaling if Volume Scaling was applied - /Mu for mu maps 	VNAP	

9.1.1.8.13 Module Image Plane (PET Image)

Table 149: Image Plane Module– PET Image

Attribute Name	Tag	VR	Source	Value	Presence	Comments
Slice Thickness	(0018,0050)	DS	AUTO		ALWAYS	Resulting slice thickness. It should be the same as the CT slice thickness if the PET reconstruction is configured to create PET image that matches CT slice location.
Image Position (Patient)	(0020,0032)	DS	AUTO		ALWAYS	The x, y, z coordinates of the center of the first pixel in mm in the CT coordinate system. The coordinates are generated after the PET/CT FOV offset correction and hence may be used directly by PET/ CT image fusion applications.
Image Orientation (Patient)	(0020,0037)	DS	AUTO		ALWAYS	Direction cosines of the first row and first column with respect to the patient.
Slice Location	(0020,1041)	DS	AUTO		ALWAYS	Relative position of the intersection of the image slice with the z-axis in mm. This position is relative to the current reference point and corresponds to the table position. It is generated after the PET/CT FOV z-offset correction.
Pixel Spacing	(0028,0030)	DS	AUTO		ALWAYS	Physical distance in the patient between the center of each pixel, specified by a numeric pair - adjacent row spacing (delimiter) adjacent column spacing in mm.

9.1.1.8.14 Module Image Pixel (PET Image)

Table 150: Image Pixel Module– PET Image

Attribute Name	Tag	VR	Source	Value	Presence	Comments
Samples per Pixel	(0028,0002)	US	AUTO		ALWAYS	Number of separate planes in the image

Photometric Interpretation	(0028,0004)	CS	AUTO		ALWAYS	Specifies the intended interpretation of the image pixel data
Rows	(0028,0010)	US	AUTO		ALWAYS	Number of rows in the image
Columns	(0028,0011)	US	AUTO		ALWAYS	Number of columns in the image
Bits Allocated	(0028,0100)	US	AUTO		ALWAYS	Number of bits allocated for each pixel sample.
Bits Stored	(0028,0101)	US	AUTO		ALWAYS	Number of bits stored for each pixel sample
High Bit	(0028,0102)	US	AUTO		ALWAYS	Most significant bit for pixel sample data
Pixel Representation	(0028,0103)	US	AUTO	0 (unsigned) or 1 (signed) depending on minimum pixel value	ALWAYS	
Smallest Image Pixel Value	(0028,0106)	US	AUTO		ALWAYS	Calculated during image reconstruction.
Largest Image Pixel Value	(0028,0107)	US	AUTO		ALWAYS	Calculated during image reconstruction.
Pixel Data	(7FE0,0010)	OW	AUTO		ALWAYS	

9.1.1.8.15 Module PET Image (PET Image)

Table 151: PET Image Module– PET Image

Attribute Name	Tag	VR	Source	Value	Presence	Comments
Image Type	(0008,0008)	CS	AUTO	For PET images: ORIGINAL PRIMARY STRESS or REST for Cardiac images For PET Topogram image: ORIGINAL PRIMARY LOCALIZER PET_TOPO For mu maps: DERIVED PRIMARY AC_MAP For statistics image: DERIVED SECONDARY OTHER For PET Patlak Slope Image:	ALWAYS	

Attribute Name	Tag	VR	Source	Value	Presence	Comments
				ORIGINAL PRIMARY PATLAK SLOPE For PET Patlak Intercept Image: ORIGINAL PRIMARY PATLAK INTERCEPT		
Acquisition Date	(0008,0022)	DA	AUTO		ALWAYS	Acquisition Date and Time is defined as the real-world beginning of the accumulation of data which contribute to a particular image. Whole Body PET images belonging to the same bed position share the same acquisition date and time. In case of dynamic studies, the acquisition time is different for different frames at the same bed position.
Acquisition Time	(0008,0032)	TM	AUTO		ALWAYS	See above
Trigger Time	(0018,1060)	DS	AUTO		ANAP	For gated only. For trigger gating: time interval in ms from start of trigger to the beginning of data acquisition for this image. For respiratory waveform gating: time offset of the start of the gate from the previous Inspiration Peak. These values are normalized across all the respiratory cycles.
Nominal Interval	(0018,1062)	IS	AUTO	.	ANAP	For gated only. Average duration of accepted beats or respirations
Frame Time	(0018,1063)	DS	AUTO		ANAP	For gated only. Nominal duration per individual frame in ms.
Low R-R Value	(0018,1081)	IS	AUTO	.	ANAP	For gated only. For trigger gating: R-R interval lower limit for beat rejection.

Attribute Name	Tag	VR	Source	Value	Presence	Comments
						For respiratory waveform gating: lowest time interval between respiratory peaks.
High R-R Value	(0018,1082)	IS	AUTO	.	ANAP	For gated only. For trigger gating: R-R interval upper limit for beat rejection. For respiratory waveform gating: lowest time interval between respiratory peaks.
Intervals Acquired	(0018,1083)	IS	AUTO	.	ANAP	For gated only. Total number of accepted beats or respiratory cycles
Intervals Rejected	(0018,1084)	IS	AUTO		ANAP	For gated only. Total number of rejected beats.
Actual Frame Duration	(0018,1242)	IS	AUTO		ALWAYS	Actual time elapsed during acquisition
Samples per Pixel	(0028,0002)	US	AUTO	1	ALWAYS	
Photometric Interpretation	(0028,0004)	CS	AUTO	MONOCHROME2	ALWAYS	
Bits Allocated	(0028,0100)	US	AUTO	16	ALWAYS	
Bits Stored	(0028,0101)	US	AUTO	16	ALWAYS	
High Bit	(0028,0102)	US	AUTO	15	ALWAYS	
Rescale Intercept	(0028,1052)	DS	AUTO	0	ALWAYS	
Rescale Slope	(0028,1053)	DS	AUTO		ALWAYS	Calculated during image reconstruction. Identical for all images in a frame if Volume Scaling is selected.
Frame Reference Time	(0054,1300)	DS	AUTO		ALWAYS	Time offset from the series time in ms. This value is different for images acquired in different bed positions or dynamic frames but is the same for all gates.

Attribute Name	Tag	VR	Source	Value	Presence	Comments
Decay Factor	(0054,1321)	DS	AUTO		ALWAYS	<p>The decay factor that was used to scale this image. The measured activity is corrected back to the reference time (0054,1102) with the following factor:</p> $e^{\lambda(t_{start}-t_{reference})} \frac{\lambda T_{frame}}{1 - e^{-\lambda T}}$ <p>with</p> $\lambda = \frac{\ln 2}{T_{1/2}}$ <p>where t_{start} is the frame start time, $t_{reference}$ the reference time, T_{frame} the frame duration, and $T_{1/2}$ the half life time of the radionuclide, see (0018,1075)</p>
Dose Calibration Factor	(0054,1322)	DS	AUTO		ALWAYS	A factor that was used to scale this image from ECAT counts/sec to Bq/ml using a dose calibrator. The value is 1 if normalization was not applied.
Scatter Fraction Factor	(0054,1323)	DS	AUTO		VNAP	An estimate of the fraction of acquired counts that were due to scatter and were corrected in this image. Value will be 0 if no scatter correction was applied.
Image Index	(0054,1330)	US	AUTO		ALWAYS	An encoded index identifying the position of the image within the PET series which is viewed as a multi-dimensional array. Used for sorting of PET images (whole body, dynamic, gated)

9.1.1.8.16 Module VOI LUT (PET Image)

Table 152: VOI LUT Module– PET Image

Attribute Name	Tag	VR	Source	Value	Presence	Comments
Window Center	(0028,1050)	DS	AUTO		ALWAYS	Calculated during image reconstruction.
Window Width	(0028,1051)	DS	AUTO		ALWAYS	Calculated during image reconstruction.

9.1.1.8.17 Module Acquisition Context (PET Image)

Table 153: Acquisition Context– PET Image

Attribute Name	Tag	VR	Source	Value	Presence	Comments
Acquisition Context Sequence	(0040,0555)	SQ	AUTO		VNAP	Present only in Blood Glucose Level is greater than zero
>Value Type	(0040,A040)	CS	FIXED		ALWAYS	
>Concept Name Code Sequence	(0040, A043)	SQ	AUTO	(109054, DCM, "Patient State")	ALWAYS	As defined in TID 3470 NM/PET Acquisition Context
>>Code Value	(0008,0100)	SH	AUTO		ALWAYS	See above
>>Coding Scheme Designator	(0008,0102)	SH	AUTO		ALWAYS	See above
>>Code Meaning	(0008,0104)	LO	AUTO		ALWAYS	See above
>Concept Code Sequence	(0040, A168)	SQ	AUTO	CID:3101 NM Procedural State Values	ALWAYS	As defined in TID 3470, the following values are used: (F-01604 ,SRT , "Resting State") (F-05019 ,SRT, "Cardiac Stress State") (109092 ,DCM , "Reinjection State") (109093 ,DCM , "Redistribution State") (109094 ,DCM , "Delayed Redistribution State")
>>Code Value	(0008,0100)	SH	AUTO		ALWAYS	See above
>>Coding Scheme Designator	(0008,0102)	SH	AUTO		ALWAYS	See above
>>Code Meaning	(0008,0104)	LO	AUTO		ALWAYS	See above
Acquisition Context Description	(0040,0556)	ST	AUTO		VNAP	Present only in Blood Glucose Level is greater than zero

9.1.1.8.18 Module SOP Common (PET Image)

Table 154: SOP Common– PET Image

Attribute Name	Tag	VR	Source	Value	Presence	Comments
Specific Character Set	(0008,0005)	CS	AUTO	ISO_IR 100	ALWAYS	
SOP Class UID	(0008,0016)	UI	AUTO	1.2.840.10008.5.1.4.1.1.128	ALWAYS	
SOP Instance UID	(0008,0018)	UI	AUTO	"1.3.12.2.1107.5.1.4."+UID	ALWAYS	

Attribute Name	Tag	VR	Source	Value	Presence	Comments
Specific Character Set	(0008,0005)	CS	AUTO	ISO_IR 100	ALWAYS	
Instance Number	(0020,0013)	IS	AUTO		ALWAYS	The order of the Instance Number is not selectable by the user. The images will be numbered in the ascending order in the direction how they are acquired.

9.1.1.8.19 Private Attributes for PET Image IOD

Table 155: Private Attributes in PET Image IOD

Tag	Private Creator Identifier	Name	VR	VM	Comments
(0071,xx21)	SIEMENS MED PT	Registration Matrix UID	UI	1	UID of Registration matrix between PET and CT images
(0071,xx22)	SIEMENS MED PT	Decay Correction DateTime	DT	1	The date and time to which the image was decay corrected. Also refer to (0054,1102)
(0071,xx23)	SIEMENS MED PT	Registration Matrix	FD	16	16 float values describing the 4x4 registration matrix from CT to PET. This will always be saved as though CT is the Base and PET is the overlay.
(0071,xx24)	SIEMENS MED PT	Table Motion	CS	1	DYNAMIC for CBM, STATIC for Step and Shoot
(0071,xx25)	SIEMENS MED PT	Lumped Constant	FD	1	For PET Patlak Images: The lumped constant (LC) used to convert an FDG metabolism to glucose metabolism.
(0071,xx26)	SIEMENS MED PT	Histogramming Method	CS	1	For CardioFreezeDual or OncoFreeze Images: Duty Cycle: xx
(0071,xx01)	SIEMENS MED PT MU MAP	SOP Class of Source	UI	1	For mu maps: 1.2.840.10008.5.1.4.1.1.2 for CT based mu maps 1.2.840.10008.5.1.4.1.1.128 for PET based mu maps
(0071,xx02)	SIEMENS MED PT MU MAP	Related Mu Map Series	UI	1	For PET images: DICOM UID of the mu map series which is used for attenuation correction of the PET images
(0071,xx30)	SIEMENS MED PT MU MAP	Prompts Rate	FD	1	Prompts per second received during the acquisition of the image. Calculated by dividing the total number of prompts acquired during the scan or time slice by the duration of the scan or time slice. Note: This is applicable only for Single Bed Protocols.

Tag	Private Creator Identifier	Name	VR	VM	Comments
(0071,xx31)	SIEMENS MED PT MU MAP	Randoms Rate	FD	1	Randoms per second received during the acquisition of the image. Calculated by dividing the total number of randoms acquired during the scan or time slice by the duration of the scan or time slice. Note: This is applicable only for Single Bed Protocols.
(0071,xx32)	SIEMENS MED PT MU MAP	Average Detector Singles Rate	FD	1	Average detector singles per second received during the acquisition of the image. Calculated by dividing the total number of singles acquired (from all detectors) during the scan or time slice by the duration of the scan or time slice and by the total number of detectors in the scanner. Note: This is applicable only for Single Bed Protocols.

9.1.1.9 Encapsulated PDF IOD

The following table specifies the Modules supported in the Encapsulated PDF IOD.

Table 156: Encapsulated PDF IOD Modules

IE	Module	Reference	Presence of Module
Patient	Patient	Table 157: Patient	ALWAYS
Study	General Study	Table 158: General Study	ALWAYS
	Patient Study	Table 159: Patient Study	ALWAYS
Series	Encapsulated Document Series	Table 160: Encapsulated Document Series	ALWAYS
Equipment	General Equipment	Table 161: General Equipment	ALWAYS
	SC Equipment	Table 162: SC Equipment	ALWAYS
Encapsulated Document	Encapsulated Document	Table 163: Encapsulated Document	ALWAYS
	SOP Common	Table 164: SOP Common	ALWAYS
	DICOM File Meta Information	Table 165	ALWAYS

9.1.1.9.1 Module Patient (Encapsulated PDF)

Table 157: Patient Module – Encapsulated PDF

Attribute Name	Tag	VR	Source	Value	Presence	Comments
Patient's Name	(0010,0010)	PN	CONFI G	"Biograph Vision Reports" or "Biograph Horizon Reports" or "Biograph Vision Reports"	ALWAYS	As the Encapsulated PDF document contains system documents like QC or Cross Calibration. So, this field does not contain the real patient's name, it contains a value picked

						from registry key based on gantry type.
Patient ID	(0010,0020)	LO	AUTO	Manufacturer Model Name Material Number-Serial Number	ALWAYS	As the Encapsulated PDF document contains system documents like QC or Cross Calibration. So, this field does not contain the real patient's ID, it contains a value "Manufacturer Model Name Material Number-Serial Number". Ex: "Biograph64_Vision 450-82126"
Patient's Birth Date	(0010,0030)	DA	AUTO		EMPTY	
Patient's Sex	(0010,0040)	CS	AUTO	O	ALWAYS	
Quality Control Subject	(0010,0200)	CS	AUTO	YES	ALWAYS	

9.1.1.9.2 Module General Study (Encapsulated PDF)

Table 158: General Study Module – Encapsulated PDF

Attribute Name	Tag	VR	Source	Value	Presence	Comments
Study Date	(0008,0020)	DA	AUTO		ALWAYS	Date that the study was created
Study Time	(0008,0030)	TM	AUTO		ALWAYS	Time that the study was created
Accession Number	(0008,0050)	SH	AUTO	EMPTY	EMPTY	
Referring Physician Name	(0008,0090)	PN	AUTO	EMPTY	EMPTY	
Study Instance UID	(0020,000D)	UI	AUTO		ALWAYS	
Study ID	(0020,0010)	SH	AUTO	EMPTY	ALWAYS	
Study Description	(0008,1030)	LO	AUTO	PET QC or PET Gantry Offset or PET Cross Calibration	ALWAYS	

9.1.1.9.3 Module Patient Study (Encapsulated PDF)

Table 159: Patient Study Module – Encapsulated PDF

Attribute Name	Tag	VR	Source	Value	Presence	Comments
Admitting Diagnoses Description	(0008,1080)	LO	MWL/ USER		VNAP	Input entered from MWL or during patient registration.

9.1.1.9.4 Module Encapsulated Document Series (Encapsulated PDF)

Table 160: Encapsulated Document Series Module – Encapsulated PDF

Attribute Name	Tag	VR	Source	Value	Presence	Comments
Series Date	(0008,0021)	DA	AUTO		ALWAYS	Date of the report
Series Time	(0008,0031)	TM	AUTO		ALWAYS	Time of the report

Series Description	(0008,103E)	LO	AUTO		ALWAYS	PDF filename without extension Ex: PETQCReport_PASS_22042022_105851
Series Instance UID	(0020,000E)	UI	AUTO		ALWAYS	
Series Number	(0020,0011)	IS	AUTO		ALWAYS	Increment by 1
Modality	(0008,0060)	CS	AUTO	PT	ALWAYS	

9.1.1.9.5 Module General Equipment (Encapsulated PDF)

Table 161: General Equipment Module – Encapsulated PDF

Attribute Name	Tag	VR	Source	Value	Presence	Comments
Manufacturer	(0008,0070)	LO	AUTO	SIEMENS	ALWAYS	
Institution Name	(0008,0080)	LO	CONFIG		ALWAYS	
Institution Address	(0008,0081)	ST	CONFIG		ALWAYS	
Station Name	(0008,1010)	SH	CONFIG		ALWAYS	
Software Versions	(0018,1020)	LO	CONFIG		ALWAYS	
Manufacturer Model Name	(0008,1090)	LO	CONFIG		ALWAYS	
Device Serial Number	(0018,1000)	LO	CONFIG		ALWAYS	
Institutional Department Name	(0008,1040)	LO	CONFIG		ALWAYS	

9.1.1.9.6 Module SC Equipment (Encapsulated PDF)

Table 162: SC Equipment Module – Encapsulated PDF

Attribute Name	Tag	VR	Source	Value	Presence	Comments
Conversion Type	(0008,0064)	CS	AUTO	SD	ALWAYS	

9.1.1.9.7 Module Encapsulated Document (Encapsulated PDF)

Table 163: Encapsulated Document Module – Encapsulated PDF

Attribute Name	Tag	VR	Source	Value	Presence	Comments
Instance Number	(0020,0013)	IS	AUTO	1	ALWAYS	
Content Date	(0008,0023)	DA	AUTO		ALWAYS	Date of QC/ Gantry Offset/ Cross calibration report
Content Time	(0008,0033)	TM	AUTO		ALWAYS	Time of QC/ Gantry Offset/ Cross calibration report
Acquisition DateTime	(0008,002A)	DT	AUTO		ALWAYS	Date/time of the acquisition of data used in the report
Burned In Annotation	(0028,0301)	CS	AUTO	NO	ALWAYS	"Indicates whether or not the encapsulated document contains sufficient burned in annotation to

						identify the patient and date the data was acquired. Enumerated Values: YES NO
Document Title	(0042,0010)	ST	AUTO		ALWAYS	Same as series description
MIME Type of Encapsulated Document	(0042,0012)	LS	AUTO	application/pdf	ALWAYS	
Concept Name Code Sequence	(0040,A043)	SQ	AUTO	EMPTY	EMPTY	
Encapsulated Document	(0042,0011)	OB	AUTO		ALWAYS	

9.1.1.9.8 Module SOP Common (Encapsulated PDF)

Table 164: SOP Common Module – Encapsulated PDF

Attribute Name	Tag	VR	Source	Value	Presence	Comments
Specific Character Set	(0008,0005)	CS	AUTO	ISO_IR 100	ALWAYS	
SOP Class UID	(0008,0016)	UI	AUTO	1.2.840.10008.5.1.4.1.1.104.1	ALWAYS	
SOP Instance UID	(0008,0018)	UI	AUTO		ALWAYS	Generated by system

9.1.1.9.9 Module DICOM File Meta Information (Encapsulated PDF)

Table 165: DICOM File Meta Information Module – Encapsulated PDF

Attribute Name	Tag	VR	Source	Value	Presence	Comments
File Meta Information Group Length	(0002,0000)	UL	AUTO		ALWAYS	
File Meta Information Version	(0002,0001)	OB	AUTO	00 01	ALWAYS	
Media Storage SOP Class UID	(0002,0002)	UI	AUTO	1.2.840.10008.5.1.4.1.1.104.1	ALWAYS	
Media Storage SOP Instance UID	(0002,0003)	UI	AUTO	1.3.12.2.1107.5.1.4.12345.30000021070808313924000000007	ALWAYS	
Transfer Syntax UID	(0002,0010)	UI	CONFIG	1.2.840.10008.1.2.1 (Explicit VR Little Endian)	ALWAYS	
Implementation Class UID	(0002,0012)	UI	AUTO	1.3.12.2.1107.5.1.4	ALWAYS	
Implementation Version Name	(0002,0013)	SH	CONFIG		ALWAYS	

9.1.1.10 Basic Directory IOD

See the following section for specific information about Basic Directory IOD written by Biograph Vision using augmented or private profiles. It will also contain extensions to the Basic Directory IOD, following PS3.11:

5.3.2.3.3 Directory Information in DICOMDIR

9.1.2 Usage of Attributes From Received IODs

See the following sections for attributes used in MPPS and IODs created by Biograph Vision.

4.2.3.3.3.2 for Patient Registration related SOP specific Conformance for SOP Classes

4.2.3.3.4.2 for Update related Proposed Presentation Contexts

9.1.1 Created SOP Instance(s)

9.1.3 Attribute Mapping

See the following sections for attributes used in MPPS and IODs created by Biograph Vision.

4.2.3.3.3.2 for Patient Registration related SOP specific Conformance for SOP Classes

4.2.3.3.4.2 for MPPS Update related Proposed Presentation Contexts

9.1.1 Created SOP Instance(s)

9.1.4 Coerced/Modified Fields

N/A

9.2 Data Dictionary of Private Attributes

9.2.1 Private Elements for all Storage SOP Classes

The following table provides an overview of all private attributes supported in syngo based applications.

Table 166: Registry of DICOM Data Elements

Tag	Private Creator Identifier	Name	VR	VM
(0029,xx08)	SIEMENS CSA HEADER	CSA Image Header Type	CS	1
(0029,xx09)	SIEMENS CSA HEADER	CSA Image Header Version	LO	1
(0029,xx10)	SIEMENS CSA HEADER	CSA Image Header Info	OB	1
(0029,xx18)	SIEMENS CSA HEADER	CSA Series Header Type	CS	1
(0029,xx19)	SIEMENS CSA HEADER	CSA Series Header Version	LO	1
(0029,xx20)	SIEMENS CSA HEADER	CSA Series Header Info	OB	1
(0029,xx08)	SIEMENS CSA NON-IMAGE	CSA Data Type	CS	1
(0029,xx09)	SIEMENS CSA NON-IMAGE	CSA Data Version	LO	1
(0029,xx10)	SIEMENS CSA NON-IMAGE	CSA Data Info	OB	1
(0029,xx08)	SIEMENS CSA REPORT	syngo Report Type	CS	1
(0029,xx09)	SIEMENS CSA REPORT	syngo Report	LO	1
(0029,xx15)	SIEMENS CSA REPORT	SR Variant	US	1
(0029,xx17)	SIEMENS CSA REPORT	SC SOP Instance UID	UI	1
(0029,xx10)	SIEMENS CSA ENVELOPE	syngo Report Data	OB	1
(0029,xx11)	SIEMENS CSA ENVELOPE	syngo Report Presentation	OB	1
(0029,xx08)	SIEMENS MEDCOM HEADER	MedCom Header Type	CS	1

Tag	Private Creator Identifier	Name	VR	VM
(0029,xx09)	SIEMENS MEDCOM HEADER	MedCom Header Version	LO	1
(0029,xx10)	SIEMENS MEDCOM HEADER	MedCom Header Info	OB	1
(0029,xx20)	SIEMENS MEDCOM HEADER	MedCom History Information	OB	1
(0029,xx31)	SIEMENS MEDCOM HEADER	PMTF Information 1	LO	1
(0029,xx32)	SIEMENS MEDCOM HEADER	PMTF Information 2	UL	1
(0029,xx33)	SIEMENS MEDCOM HEADER	PMTF Information 3	UL	1
(0029,xx34)	SIEMENS MEDCOM HEADER	PMTF Information 4	CS	1
(0029,xx35)	SIEMENS MEDCOM HEADER	PMTF Information 5	UL	1
(0029,xx40)	SIEMENS MEDCOM HEADER	Application Header Sequence	SQ	1
(0029,xx41)	SIEMENS MEDCOM HEADER	Application Header Type	CS	1
(0029,xx42)	SIEMENS MEDCOM HEADER	Application Header ID	LO	1
(0029,xx43)	SIEMENS MEDCOM HEADER	Application Header Version	LO	1
(0029,xx44)	SIEMENS MEDCOM HEADER	Application Header Info	OB	1
(0029,xx50)	SIEMENS MEDCOM HEADER	Workflow Control Flags	LO	8
(0029,xx51)	SIEMENS MEDCOM HEADER	Archive Management Flag Keep Online	CS	1
(0029,xx52)	SIEMENS MEDCOM HEAD	Archive Management Flag Do Not Archive	CS	1
(0029,xx53)	SIEMENS MEDCOM HEADER	Image Location Status	CS	1
(0029,xx54)	SIEMENS MEDCOM HEADER	Estimated Retrieve Time	DS	1
(0029,xx55)	SIEMENS MEDCOM HEADER	Data Size of Retrieved Images	DS	1
(0029,xx70)	SIEMENS MEDCOM HEADER	Siemens Link Sequence	SQ	1
(0029,xx71)	SIEMENS MEDCOM HEADER	Referenced Tag	AT	1
(0029,xx72)	SIEMENS MEDCOM HEADER	Referenced Tag Type	CS	1
(0029,xx73)	SIEMENS MEDCOM HEADER	Referenced Value Length	UL	1
(0029,xx74)	SIEMENS MEDCOM HEADER	Referenced Object Device Type	CS	1
(0029,xx75)	SIEMENS MEDCOM HEADER	Referenced Object Device Location	OB	1
(0029,xx76)	SIEMENS MEDCOM HEADER	Referenced Object ID	OB	1
(0029,xx60)	SIEMENS MEDCOM HEADER2	Series Work Flow Status	LO	1
(0029,xx08)	SIEMENS MEDCOM OOG	MEDCOM OOG Type	CS	1
(0029,xx09)	SIEMENS MEDCOM OOG	MEDCOM OOG Version	LO	1
(0029,xx10)	SIEMENS MEDCOM OOG	MEDCOM OOG Info	OB	1
(7FE1,xx10)	SIEMENS CSA NON-IMAGE	CSA Data	OB	1

9.2.1.1 Extended Image IOD Module Table

The following Table describes the extension with private modules of the Image IODs supported by the Biograph Vision DICOM application

Table 167: Extensions of Image IODs

IE	Module	Reference	Usage	Note	
Patient	Patient	See IOD specific subsection in Section 9.1.1	M		
Study	General Study		M		
	Patient Study		U		
Series	General Series		M		
Equipment	General Equipment		U		
Image	General Image		M		
	Image Pixel		M		
	IOD specific modules		M/U	depends on the IOD	
	CSA Image Header		Table 78	U	
	CSA Series Header		Table 79	U	
	MEDCOM Header	Table 80	U	private <i>syngo</i> information	
	MEDCOM OOG	Table 81	U	if object graphics is attached to image	
SOP Common	See IOD specific subsection in Section 9.1.1	M			

9.2.2 Private Elements for CT Image Storage SOP Class

The following private attributes are defined for Biograph Vision.

Table 168: Registry of DICOM Data Elements

Tag	Private Creator Identifier	Name	VR	VM	Notes
(0019,xx90)	SIEMENS CT VA0 COAD	Osteo Offset	DS	1	Offset of the water equivalent material of the Siemens Osteo phantom to real water
(0019,xx92)	SIEMENS CT VA0 COAD	Osteo Regression Line Slope	DS	1	Slope of the regression line for the ESP (=European Spine Phantom) standardization
(0019,xx93)	SIEMENS CT VA0 COAD	Osteo Regression Line Intercept	DS	1	Intercept of the regression line for the ESP (= European Spine Phantom) standardization
(0019,xx96)	SIEMENS CT VA0 COAD	Osteo Phantom Number	IS	1	Number of the Siemens Osteo phantom

Tag	Private Creator Identifier	Name	VR	VM	Notes
(0019,xxB0)	SIEMENS CT VA0 COAD	Feed per Rotation	DS	1	Som/4 style Feed per Rotation (Backwards Compatibility)
(0019,xxBD)	SIEMENS CT VA0 COAD	Pulmo Trigger Level	IS	1	Spirometer trigger level used for the scan, given in percent of VC (= Vital Capacity) of the patient
(0019,xxBE)	SIEMENS CT VA0 COAD	Expiratoric Reserve Volume	DS	1	ERV (= Expiratoric Reserve Volume) achieved by the patient
(0019,xxBF)	SIEMENS CT VA0 COAD	Vital Capacity	DS	1	VC (= Vital Capacity) achieved by the patient
(0019,xxC0)	SIEMENS CT VA0 COAD	Pulmo Water	DS	1	Density of the water insert of the Siemens Pulmo phantom
(0019,xxC1)	SIEMENS CT VA0 COAD	Pulmo Air	DS	1	Density of the air holes of the Siemens Pulmo phantom
(0019,xxC2)	SIEMENS CT VA0 COAD	Pulmo Date	DA	1	Date of the evaluation of the Siemens Pulmo phantom
(0019,xxC3)	SIEMENS CT VA0 COAD	Pulmo Time	TM	1	Time of the evaluation of the Siemens Pulmo phantom
(0021xx11)	SIEMENS MED	Target	DS	2	Som/4 style Target (Backwards Compatibility)
(0009,00xx)	SIEMENS CT VA1 DUMMY	Private Creator Data Element	LO	1	1

9.3 Coded Terminology and Templates

Biograph Vision generally uses SNOMED RT (SRT) codes even though the current version of the DICOM standard uses SNOMED CT (SCT) codes as coding scheme designator.

9.3.1 Context Groups

Table 169 : Context Groups

Context Group	Default Value Set	Configurable	Use
Related Series Purpose of Reference	CID 7210	Extensible	Value of Purpose of Reference Code Sequence (0040,A170) in SOP Common Module of Positron Emission Tomography Image IOD, see Error! Reference source not found. for extended value sets
PET Radionuclide	CID 4020	Extensible	Value of Radionuclide Code Sequence (0054,0300) in PET Isotope Module of Positron Emission Tomography Image IOD, see Error! Reference source not found. for supported value sets Value of Content Sequence (0040,A730) in SR Document Content Module of Radiopharmaceutical Radiation Dose SR IOD, see Error! Reference source not found. for supported value sets
PET Radiopharmaceutical	CID 4021	Extensible	Value of Radiopharmaceutical Code Sequence (0054,0304) in PET Isotope Module of Positron Emission Tomography Image IOD, see Table 172 for supported value sets Value of Content Sequence (0040,A730) in SR Document Content Module of Radiopharmaceutical Radiation Dose SR IOD, see Table 174 Error! Reference source not found. for supported value sets
Radiosensitive Organ	CID 10044	Extensible	Organs used for reporting in PET RRDSR Instances. Value of Content Sequence (0040,A730) in SR Document Content Module of Radiopharmaceutical Radiation Dose SR IOD, see Table 175 or supported value sets
Patient Orientation	CID 19	Extensible	Patient Orientation Code Sequence (0054,0410) in Table 144
Patient Orientation Modifier	CID 20	Extensible	Patient Orientation Modifier Code Sequence (0054, 0412) in Table 144
Patient Gantry Relationship	CID 21	Extensible	Patient Gantry Relationship Code Sequence (0054, 0414) in Table 144

9.3.1.1 Supported Codes for Purpose of Reference Code Sequence

Table 170: Codes for Purpose of Reference Code Sequence

Coding Scheme Designator (0008,0102)	Code Value (0008,0100)	Code Meaning (0008,0104)
DCM	122401	Same Anatomy (indicating that the referenced CT series is used for slice matching)
DCM	122403	For Attenuation Correction (indicating that the referenced CT series is used for attenuation correction)

9.3.1.2 Supported Radionuclides for Created PET Images

Table 171: Supported Radionuclides for Created PET Images

Coding Scheme Designator (0008,0102)	Code Value (0008,0100)	Code Meaning (0008,0104)
SRT	C-111A1	¹⁸ F
SRT	C-159A2	⁸² Rb
SRT	C-107A1	¹³ N
SRT	C-105A1	¹¹ C
SRT	C-128A2	⁶⁸ Ge
SRT	C-155A1	²² Na
SRT	C-1018C	¹⁴ O
SRT	C-B1038	¹⁵ O
SRT	C-127A4	⁶⁰ Cu
SRT	C-127A1	⁶¹ Cu
SRT	C-127A5	⁶² Cu
SRT	C-127A2	⁶⁴ Cu
SRT	C-131A1	⁶⁶ Ga
SRT	C-131A3	⁶⁸ Ga
SRT	C-113A1	⁷⁵ Br
SRT	C-113A2	⁷⁶ Br
SRT	C-113A3	⁷⁷ Br
SRT	C-114A5	¹²⁴ I
SRT	C-135A4	³⁸ K
SRT	C-149A1	⁵² Mn
SRT	C-163AA	^{94m} Tc
SRT	C-166A2	⁴⁵ Ti
SRT	C-162A3	⁸⁶ Y
SRT	C-141A1	⁶² Zn

Coding Scheme Designator (0008,0102)	Code Value (0008,0100)	Code Meaning (0008,0104)
DCM	126600	^44^Scandium
DCM	126605	^43^Scandium
DCM	126602	^70^Arsenic
SRT	C-115A2	^72^Arsenic
SRT	C-116A2	^72^Selenium
DCM	126603	^90^Niobium
DCM	126606	^152^Terbium
SRT	C-130A1	^52^Iron
DCM	126601	^51^Manganese
SRT	C-162A7	^90^Yttrium
SRT	C-168A4	^89^Zirconium

9.3.1.3 Supported Radiopharmaceuticals for Created PET Images

Table 172: Supported Radiopharmaceuticals for Created PET Images

Coding Scheme Designator (0008,0102)	Code Value (0008,0100)	Code Meaning (0008,0104)
SRT	C-B1043	Acetate C^11^
SRT	C-B103C	Ammonia N^13^
SRT	C-B07DB	ATSM Cu^64^
SRT	C-B07DC	Butanol O^15^
SRT	C-B103B	Carbon dioxide O^15^
SRT	C-B1045	Carbon monoxide C^11^
SRT	C-B103A	Carbon monoxide O^15^
SRT	C-B103F	Carfentanil C^11^
SRT	C-B07DD	EDTA Ga^68^
SRT	C-B07DE	Flumazenil C^11^
SRT	C-B07DF	Flumazenil F^18^
SRT	C-B07E0	Fluorethyltyrosin F^18^
SRT	C-B1031	Fluorodeoxyglucose F^18^
SRT	C-B07E1	Fluoromisonidazole F^18^
SRT	C-B07E2	Fluoromethane F^18^
SRT	C-B07E3	Fluorouracil F^18^
SRT	C-B07E4	Fluorobenzothiazole F^18^

Coding Scheme Designator (0008,0102)	Code Value (0008,0100)	Code Meaning (0008,0104)
SRT	C-B1034	Fluoro-L-dopa F^18^
SRT	C-B1046	Germanium Ge^68^
SRT	C-B103D	Glutamate N^13^
SRT	C-B07E5	Mespiperone C^11^
SRT	C-B103E	Methionine C^11^
SRT	C-B07E6	Monoclonal antibody I^124^
SRT	C-B1038	Oxygen O^15^
SRT	C-B1039	Oxygen-water O^15^
SRT	C-B1044	Palmitate C^11^
SRT	C-B07E7	PTSM Cu^62^
SRT	C-B1042	Raclopride C^11^
SRT	C-B1037	Rubidium chloride Rb^82^
SRT	C-B1032	Sodium fluoride F^18^
SRT	C-B07E8	Sodium iodide I^124^
SRT	C-B1047	Sodium Na^22^
SRT	C-B1033	Spiperone F^18^
SRT	C-B1036	Thymidine (FLT)F^18^
DCM	126713	2FA F^18^
DCM	126700	ATSM Cu^60^
DCM	126701	ATSM Cu^61^
DCM	126702	ATSM Cu^62^
DCM	126516	Bevacizumab ^89^Zr
DCM	126513	Cetuximab ^89^Zr
DCM	126703	Choline C^11^
DCM	126517	cG250-F(ab')(2) ^89^Zr
DCM	126715	CLR1404 I^124^
DCM	126515	cU36 ^89^Zr
DCM	126520	Df-CD45 ^89^Zr
DCM	126519	E4G10 ^89^Zr
UMLS	C2713594	Edotreotide Ga^68^
DCM	126704	Fallypride C^11^
DCM	126705	Fallypride F^18^

Coding Scheme Designator (0008,0102)	Code Value (0008,0100)	Code Meaning (0008,0104)
DCM	126706	FLB 457 C ¹¹ [^]
DCM	126503	Flubatine F ¹⁸ [^]
DCM	126501	Florbetaben F ¹⁸ [^]
SRT	C-E0269	Florbetapir F ¹⁸ [^]
SRT	C-E0265	Fluciclatide F ¹⁸ [^]
SRT	C-E026A	Fluciclovine F ¹⁸ [^]
UMLS	C1831937	Fluoroestradiol (FES) F ¹⁸ [^]
UMLS	C1541539	Fluoroetanidazole F ¹⁸ [^]
SRT	C-E0273	Fluorocholine F ¹⁸ [^]
UMLS	C2934038	Fluoropropyl-dihydrotrabenazine (DTBZ) F ¹⁸ [^]
DCM	126707	Fluorotriopride F ¹⁸ [^]
SRT	C-E0267	Flutemetamol F ¹⁸ [^]
DCM	126709	Glutamine C ¹¹ [^]
DCM	126711	Glutamine F ¹⁸ [^]
UMLS	C2981788	ISO-1 F ¹⁸ [^]
DCM	126514	J591 ⁸⁹ Zr
DCM	126510	Monoclonal Antibody (mAb) ⁶⁴ Cu
DCM	126511	Monoclonal Antibody (mAb) ⁸⁹ Zr
DCM	126714	Nifene F ¹⁸ [^]
DCM	126500	Pittsburgh compound B C ¹¹ [^]
DCM	126518	R1507 ⁸⁹ Zr
DCM	126502	T807 F ¹⁸ [^]
DCM	126512	Trastuzumab ⁸⁹ Zr
UMLS	C1742831	tyrosine-3-octreotate Ga ⁶⁸ [^]
DCM	126752	28H1 ⁸⁹ Zr
DCM	126751	7D12 ⁸⁹ Zr
DCM	126750	7E11 ⁸⁹ Zr
DCM	126729	AGN-150998 ⁸⁹ Zr
DCM	126754	Anti-B220 ⁸⁹ Zr
DCM	126722	Benralizumab ⁸⁹ Zr

Coding Scheme Designator (0008,0102)	Code Value (0008,0100)	Code Meaning (0008,0104)
DCM	126727	Blinatumomab ^89^Zr
DCM	126735	Brentuximab ^89^Zr
DCM	126746	cMAb U36 ^89^Zr
DCM	126762	Df-[FK](2) ^89^Zr
DCM	126763	Df-[FK](2)-3PEG(4) ^89^Zr
DCM	126760	Df-FK ^89^Zr
DCM	126761	Df-FK-PEG(3) ^89^Zr
DCM	126747	DN30 ^89^Zr
DCM	126732	Ecromeximab ^89^Zr
DCM	126748	Fresolimumab ^89^Zr
DCM	126731	GA201 ^89^Zr
DCM	126724	Glembatumumab vedotin ^89^Zr
DCM	126740	Margetuximab ^89^Zr
DCM	126730	MEDI-551 ^89^Zr
DCM	126738	Mogamulizumab ^89^Zr
DCM	126753	Nanocolloidal albumin ^89^Zr
DCM	126721	Obinituzimab ^89^Zr
DCM	126723	Ocaratuzumab ^89^Zr
DCM	126736	Panitumumab ^89^Zr
DCM	126728	Pegdinetanib ^89^Zr
DCM	126725	Pinatuzumab vedotin ^89^Zr
DCM	126726	Polatuzumab vedotin ^89^Zr
DCM	126742	Ranibizumab ^89^Zr
DCM	126737	Rituximab ^89^Zr
DCM	126755	RO5323441 ^89^Zr
DCM	126756	RO542908 ^89^Zr
DCM	126733	Roledumab ^89^Zr
DCM	126741	SAR3419 ^89^Zr
DCM	126749	TRC105 ^89^Zr
DCM	126739	Ublituximab ^89^Zr
DCM	126734	XmAb5574 ^89^Zr

9.3.1.4 Supported Radionuclides for Created PET RRDSR Instances

Table 173: Supported Radionuclides for Created PET RRDSR Instances

Coding Scheme Designator (0008,0102)	Code Value (0008,0100)	Code Meaning (0008,0104)
SRT	C-111A1	¹⁸ F
SRT	C-159A2	⁸² Rb
SRT	C-107A1	¹³ N
SRT	C-105A1	¹¹ C
SRT	C-155A1	²² Na
SRT	C-B1038	¹⁵ O

9.3.1.5 Supported Radiopharmaceuticals for Created PET RRDSR Instances

Table 174: Supported Radiopharmaceuticals for Created PET RRDSR Instances

Coding Scheme Designator (0008,0102)	Code Value (0008,0100)	Code Meaning (0008,0104)
SRT	C-B1043	Acetate ¹¹ C
SRT	C-B103C	Ammonia ¹³ N
SRT	C-B103F	Carfentanil ¹¹ C
SRT	C-B07E0	Fluorethyltyrosin ¹⁸ F
SRT	C-B1031	Fluorodeoxyglucose ¹⁸ F
SRT	C-B1034	Fluoro-L-dopa ¹⁸ F
SRT	C-B103E	Methionine ¹¹ C
SRT	C-B1039	Oxygen-water ¹⁵ O
SRT	C-B1042	Raclopride ¹¹ C
SRT	C-B1037	Rubidium chloride ⁸² Rb
SRT	C-B1032	Sodium fluoride ¹⁸ F
SRT	C-B1036	Thymidine (FLT) ¹⁸ F

9.3.1.6 Organs used for Reporting in Created PET RRDSR Instances

The following table shows the organs for which Organ Dose will be reported along with the corresponding laterality. Testis only included for patient sex "M". Ovary and Uterus only included for patient sex "F".

Table 175: Organs used for Reporting in Created PET RRDSR Instances

Coding Scheme Designator (0008,0102)	Code Value (0008,0100)	Code Meaning (0008,0104)	Laterality
SRT	T-B3000	Adrenal gland	Right and Left

Coding Scheme Designator (0008,0102)	Code Value (0008,0100)	Code Meaning (0008,0104)	Laterality
SRT	T-D0859	Bone Surface	N/A
SRT	T-A0100	Brain	N/A
SRT	T-04000	Breast	Right and Left
SRT	T-63000	Gall bladder	N/A
SRT	T-57000	Stomach	N/A
SRT	T-58000	Small intestine	N/A
SRT	T-59300	Colon	N/A
SRT	T-32000	Heart	N/A
SRT	T-71000	Kidney	Right and Left
SRT	T-62002	Liver	N/A
SRT	T-28000	Lung	Right and Left
SRT	T-13001	Muscle	N/A
SRT	T-56000	Esophagus	N/A
SRT	T-65000	Pancreas	N/A
SRT	T-C1000	Bone Marrow	N/A
SRT	T-00009	Skin	N/A
SRT	T-C3000	Spleen	N/A
SRT	T-87000	Ovary	Right and Left
SRT	T-83000	Uterus	N/A
SRT	T-94000	Testis	Right and Left
SRT	T-C8000	Thymus	N/A
SRT	T-B6000	Thyroid	N/A
SRT	T-74000	Bladder	N/A

9.3.2 Template Specifications

9.3.2.1 X-Ray Radiation Dose SR IOD Templates

The X-Ray Radiation Dose SR complies with the templates defined in the DICOM Standard "CT Radiation Dose" (TID 10011), "CT Accumulated Dose Data" (TID 10012), "CT Irradiation Event Data" (TID 10013), and "CT Dose Check Details" (TID 10015) and supports all mandatory elements.

Figure 10 shows the hierarchy of templates used to create instances of the X-Ray Radiation Dose SR IOD.

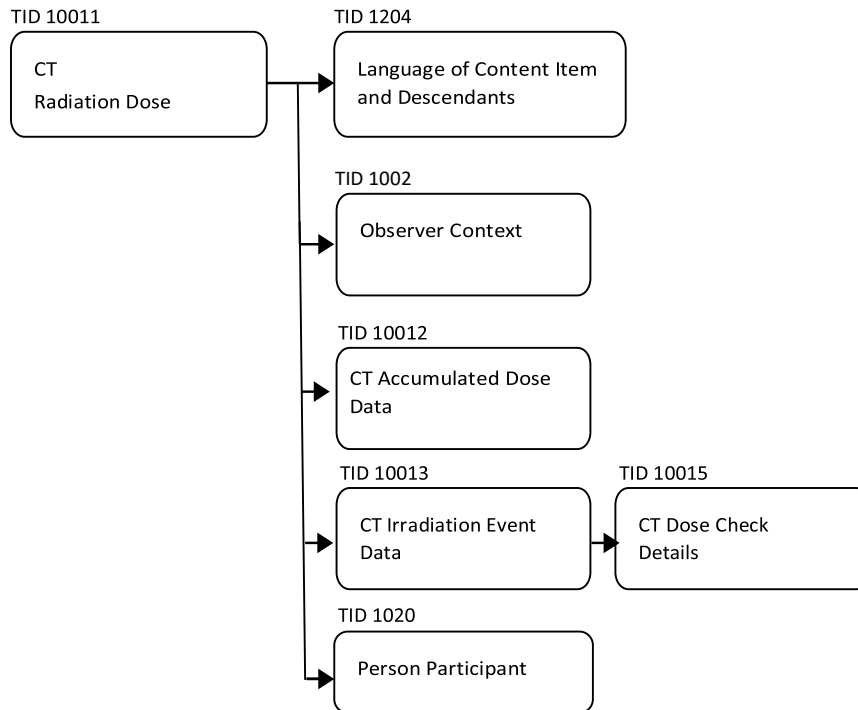

Figure 10: Hierarchy of Templates in X-Ray Radiation Dose SR

The following tables contain the content of the X-Ray Radiation Dose SR

9.3.2.1.1 TID 10011 CT Radiation Dose

Table 176: TID 10011 CT Radiation Dose

NL	Rel with Parent	VT	Concept Name	VM	Presence	Values
		CONTAINER	EV (113701, DCM, "X-Ray Radiation Dose Report")	1	ALWAYS	Root node
>	HAS CONCEPT MOD	CODE	EV (121058, DCM, "Procedure Reported")	1	ALWAYS	(7747700, SCT, "Computed Tomography X-Ray")
>>	HAS CONCEPT MOD	CODE	EV (G-C0E8, SRT, "Has Intent")	1	ALWAYS	EV (R-408C3, SRT, "Diagnostic Intent")
>		INCLUDE	DTID 1002 "Observer Context"	1	ALWAYS	See Table 177: TID 1002 Observer Context
>	HAS OBS CONTEXT	DATETIME	EV (113809, DCM, "Start of X-Ray Irradiation")	1	ALWAYS	
>	HAS OBS CONTEXT	DATETIME	EV (113810, DCM, "End of X-Ray Irradiation")	1	ALWAYS	
>	HAS OBS CONTEXT	CODE	EV (113705, "Scope of Accumulation")	1	ALWAYS	(113014, DCM, "Study")
>>	HAS PROPERTIES	UIDREF	EV (111080, DCM, "Study Instance UID")	1	ALWAYS	
>	CONTAINS	INCLUDE	DTID 10012 "CT Accumulated Dose Data"	1	ALWAYS	See Table 179: TID 10012 CT Accumulated Dose Data

NL	Rel with Parent	VT	Concept Name	VM	Presence	Values
>	CONTAINS	INCLUDE	DTID 10013, "CT Irradiation Event Data"	1-n	ALWAYS	For each Irradiation Event see Table 180: TID 10013 CT Irradiation Event Data
>	CONTAINS	CODE	EV (113854, DCM, "Source of Dose Information")	1-n	ALWAYS	(113856, DCM, "Automated Data Collection")

9.3.2.1.2 TID 1002 Observer Context

Table 177: TID 1002 Observer Context

NL	Rel with Parent	VT	Concept Name	VM	Presence	Values
	HAS OBS CONTEXT	CODE	EV (121005, DCM, "Observer Type")	1	ALWAYS	(121007, DCM, "Device")
>	HAS OBS CONTEXT	INCLUDE	DTID 1004 "Device Observer Identifying Attributes"	1	ALWAYS	See Table 178: TID 1004 Device Observer Identifying Attributes

9.3.2.1.3 TID 1004 Device Observer Identifying Attributes

Table 178: TID 1004 Device Observer Identifying Attributes

NL	Rel with Parent	VT	Concept Name	VM	Presence	Values
>	HAS OBS CONTEXT	UIDREF	EV (121012, DCM, "Device Observer UID")	1	ALWAYS	
>	HAS OBS CONTEXT	TEXT	EV (121013, DCM, "Device Observer Name")	1	ALWAYS	Table 86
>	HAS OBS CONTEXT	TEXT	EV (121014, DCM, "Device Observer Manufacturer")	1	ALWAYS	"SIEMENS"
>	HAS OBS CONTEXT	TEXT	EV (121015, DCM, "Device Observer Model Name")	1	ALWAYS	Table 113: Enhanced General Equipment Module – X-Ray Radiation Dose SR Instance
>	HAS OBS CONTEXT	TEXT	EV (121016, DCM, "Device Observer Serial Number")	1	ALWAYS	Table 86
>	HAS OBS CONTEXT	TEXT	EV (121017, DCM, "Device Observer Physical Location During Observation")	1	ALWAYS	Institution Name from configuration

9.3.2.1.4 TID 10012 CT Accumulated Dose Data

Table 179: TID 10012 CT Accumulated Dose Data

NL	Rel with Parent	VT	Concept Name	VM	Presence	Values
		CONTAINER	EV (113811, DCM, "CT Accumulated Dose Data")	1	ALWAYS	
>	CONTAINS	NUM	EV (113812, DCM, "Total Number of Irradiation Events")	1	ALWAYS	Unit ({events}, UCUM, "events")
>	CONTAINS	NUM	EV (113813, DCM, "CT Dose Length Product")	1	ALWAYS	Unit (mGy.cm, UCUM, "mGy.cm")

9.3.2.1.5 TID 10013 CT Irradiation Event Data

Table 180: TID 10013 CT Irradiation Event Data

NL	Rel with Parent	VT	Concept Name	VM	Presence	Values
		CONTAINER	EV (113819, DCM, "CT Acquisition")	1	ALWAYS	
>	CONTAINS	TEXT	EV (125203, DCM, "Acquisition Protocol")	1	ALWAYS	e.g. "Topogram"
>	CONTAINS	CODE	EV (123014, DCM, "Target Region")	1	ALWAYS	See DCID 4030 "CT, MR, and PET Anatomy"
>	CONTAINS	CODE	EV (123820, DCM, "Acquisition Type")	1	ALWAYS	e.g. (113805, DCM, "Constant Angle Acquisition")
>	CONTAINS	CODE	EV (G-C32C, SRT, "Procedure Context")	1	ALWAYS	(P5-0808E, SRT, "CT without contrast") or (P5-00100, SRT, "Diagnostic radiography with contrast media")
>	CONTAINS	UIDREF	EV (113769, DCM, "Irradiation Event UID")	1	ALWAYS	
>	CONTAINS	CONTAINER	EV (113822, DCM, "Acquisition Parameters")	1	ALWAYS	
>>	CONTAINS	NUM	EV (113824, DCM, "Exposure Time")	1	ALWAYS	Unit (s, UCUM[1.4], "s")
>>	CONTAINS	NUM	EV (113825, DCM, "Scanning Length")	1	ALWAYS	Unit (mm, UCUM[1.4], "mm")
>>	CONTAINS	NUM	EV (223826, DCM, "Nominal Single Collimation Width")	1	ALWAYS	Unit (mm, UCUM[1.4], "mm")
>>	CONTAINS	NUM	EV (113827, DCM, "Nominal Total Collimation Width")	1	ALWAYS	Unit (mm, UCUM[1.4], "mm")
>>	CONTAINS	NUM	EV (113828, DCM, "Pitch Factor")	1	VNAP	UNIT ({ratio}, UCUM, "ratio")
>>	CONTAINS	NUM	EV (113823, DCM, "Number of X-Ray Sources")	1	ALWAYS	Unit ({X-Ray sources}, UCUM[1.4], "X-Ray sources")
>>	CONTAINS	CONTAINER	EV (113831, DCM, "CT X-Ray Source Parameters")	1-n	ALWAYS	
>>>	CONTAINS	TEXT	EV (113832, DCM, "Identification of the X-Ray Source")	1	ALWAYS	"A"
>>>	CONTAINS	NUM	EV (113733, DCM, "KVP")	1	ALWAYS	Unit (kV, UCUM, "kV")
>>>	CONTAINS	NUM	EV (113833, DCM, "Maximum X-Ray Tube Current")	1	ALWAYS	Unit (mA, UCUM, "mA")
>>>	CONTAINS	NUM	EV (113734, DCM, "X-Ray Tube Current")	1	ALWAYS	Unit (mA, UCUM, "mA")
>>>	CONTAINS	NUM	EV 113834, DCM, "Exposure Time per Rotation")	1	VNAP	Unit (mA, UCUM, "mA")
>	CONTAINS	CONTAINER	EV (113829, DCM, "CT Dose")	1	VNAP	Unit (s, UCUM, "s")
>>	CONTAINS	NUM	EV (113830, DCM, "Mean CT DIvol")	1	ALWAYS	Unit (mGy, UCUM, "mGy")
>>	CONTAINS	CODE	EV (113835, DCM, "CTDIw Phantom Type")	1	ALWAYS	(113691, DCM, "IEC Body Dosimetry Phantom")
>>	CONTAINS	NUM	EV (113838, DCM, "DLP")	1	ALWAYS	Unit (mGy.cm, UCUM, "mGy.cm")
>>	CONTAINS	NUM	EV (113930, DCM, "Size Specific Dose Estimate")	1	ALWAYS	Unit (mGy, UCUM, "mGy")

NL	Rel with Parent	VT	Concept Name	VM	Presence	Values
>>>	HAS CONCEPT MOD	CODE	EV (370129005, SCT, "Measurement method")	1	ALWAYS	(113989, DCM, "Arithmetic Average of SSDE(z)")
>>>	INFERRED FROM	NUM	EV (113980, DCM, "Water Equivalent Diameter")	1	ALWAYS	Unit (mm, UCUM[1.4], "mm")
>>>>	HAS CONCEPT MOD	CODE	EV (370129005, SCT, "Measurement method")	1	ALWAYS	(113984, DCM, »Water Equivalent Diameter From Localizer)
>>>	INFERRED FROM	NUM	(113993, DCM, "Size Specific Dose Estimate At Longitudinal Position Z")	1-n	ALWAYS	Unit (mGy, UCUM, "mGy")
>>>>	INFERRED FROM	NUM	EV (113994, DCM, "Longitudinal Position Z")	1	ALWAYS	Unit (mm, UCUM, "mm")
>>>>	INFERRED FROM	NUM	EV (113995, DCM, "Water Equivalent Diameter At Longitudinal Position Z")	1	ALWAYS	Unit (mGy, UCUM, "mGy")
>>	CONTAINS	INCLUDE	DTID 10015 "CT Dose Check Details"	1	ALWAYS	See Table 181: TID 10015 CT Dose Check Details
>	CONTAINS	TEXT	EV (113842, DCM, "X-Ray Modulation Type")	1	ALWAYS	e.g. "XYZ_EC"
>	CONTAINS	TEXT	EV (121106, DCM, "Comment")	1	ALWAYS	e.g. "Internal technical scan parameters: Organ Characteristic = Abdomen, Body Size = Adult, Body Region = Body, X-ray Modulation Type = XYZ_EC, Sn Filter (Tube A) = no"
>	CONTAINS	INCLUDE	DTID 100015, "CT Dose Check Details"	1	ALWAYS	See Table 181: TID 10015 CT Dose Check Details

9.3.2.1.6 TID 10015 CT Dose Check Details

Table 181: TID 10015 CT Dose Check Details

NL	Rel with Parent	VT	Concept Name	VM	Presence	Values
		CONTAINER	EV (113900, DCM, "Dose Check Alert Details")	1	VNAP	Only if Dose Alert is configured
>	CONTAINS	CODE	EV (113901, DCM, "DLP Alert Value Configured")	1	ALWAYS	(R-00339, SRT, "No")
>	CONTAINS	CODE	EV (113902, "CTDIvol Alert Value Configured")	1	ALWAYS	(R-0038D, SRT, "Yes")
>	CONTAINS	NUM	EV (113904, DCM, "CTDIvol Alert Value")	1	ALWAYS	1000 Unit (mGy, UCUM, "mGy")
	CONTAINS	CODE	EV (113915, DCM, "Alternative Dose Alert behavior active")	1	ALWAYS	Unit (R-00339, SRT, "No")
		CONTAINER	EV (113908, DCM, "Dose Check Notification Details")	1	ALWAYS	
>	CONTAINS	CODE	EV (113909, DCM, "DLP Notification Value Configured")	1	ALWAYS	(R-00339, SRT, "No")
>	CONTAINS	CODE	EV (113910, DCM, "CTDIvol Notification Value Configured")	1	ALWAYS	(R-00339, SRT, "No")

9.3.2.2 Radiopharmaceutical Radiation Dose Structured Report IOD Templates

The Radiopharmaceutical Radiation Dose Structured Report generally follows the templates defined in the DICOM Standard "Radiopharmaceutical Radiation Dose" (TID 10021), "Radiopharmaceutical Administration Event Data" (TID 10022), "Radiopharmaceutical Administration Patient Characteristics" (TID 10024) and supports all mandatory elements.

Figure 11 shows the hierarchy of templates used to create instances of the Radiopharmaceutical Radiation Dose Structured Report IOD.

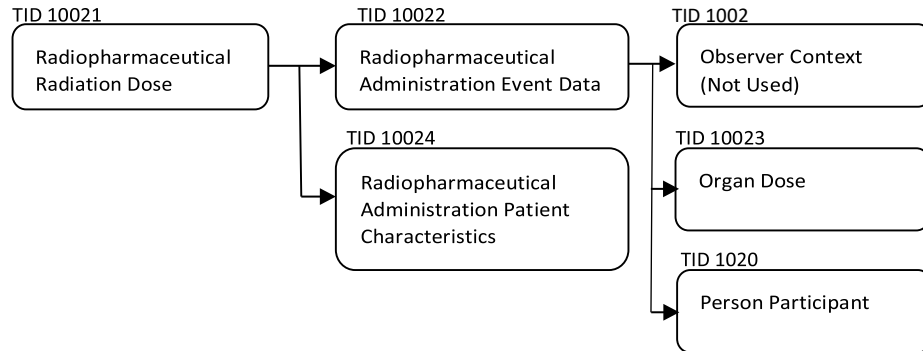

Figure 11: Hierarchy of Templates in Radiopharmaceutical Radiation Dose SR

Not all the organs from ICRP publications are encoded using TID 10023 (e.g., Remaining Organs, Other Tissues), as these are included in the effective dose, but not included as individual organs as there are no corresponding DICOM-conformant coded terms for these organs (or sets of organs) at this time.

For dose reports with ICRP 53 as a reference authority, the following method is used to calculate the organ absorbed dose for the Colon Wall using the organ dose values for Upper Large Intestine (ULI) and Lower Large Intestine (LLI).

$$\text{Colon} = 0.57\text{ULI} + 0.43\text{LLI}$$

9.3.2.2.1 TID 10021 Radiopharmaceutical Radiation Dose

Table 182: TID 10021 Radiopharmaceutical Radiation Dose

NL	Rel with Parent	VT	Concept Name	Presence	Values
		CONTAINER	EV (113500, DCM, "Radiopharmaceutical Radiation Dose SR")	AUTO	Root node
>	HAS CONCEPT MOD	CODE	EV (G-C2D0, SRT, "Associated Procedure")	AUTO	EV (P5-0A00A, SRT, "PET study for localization of tumor")
>>	HAS CONCEPT MOD	CODE	EV (G-C0E8, SRT, "Has Intent")	AUTO	EV (R-408C3, SRT, "Diagnostic Intent")
>	CONTAINS	INCLUDE	DTID 10022 "Radiopharmaceutical Administration Event Data"	AUTO	See Table 183: TID 10022 Radiopharmaceutical Administration Event
>	CONTAINS	INCLUDE	DTID 10024 "Imaging Agent Administration Patient Characteristics"	AUTO	See Table 184: TID 10024 Imaging Agent Administration Patient Characteristics

9.3.2.2.2 TID 10022 Radiopharmaceutical Administration Event Data

Table 183: TID 10022 Radiopharmaceutical Administration Event Data

NL	Rel with Parent	VT	Concept Name	Presence	Values
		CONTAINER	EV (113502, DCM, "Radiopharmaceutical Administration")	AUTO	
>	CONTAINS	CODE	(F-61FDB, SRT, "Radiopharmaceutical agent")	AUTO	See Table 174: Supported Radiopharmaceuticals for Created PET RRDSR Instances
>>	HAS PROPERTIES	CODE	(C-10072, SRT, "Radionuclide")	AUTO	See Table 173: Supported Radionuclides for Created PET RRDSR Instances
>>	HAS PROPERTIES	NUM	(R-42806, SRT, "Radionuclide Half Life")	AUTO	Unit (s, UCUM, "seconds")
>	CONTAINS	UIDREF	(113503, DCM, "Radiopharmaceutical Administration Event UID")	AUTO	
>	CONTAINS	DATETIME	(123003, DCM, "Radiopharmaceutical Start DateTime")	AUTO	
>	CONTAINS	DATETIME	(123004, DCM, "Radiopharmaceutical Stop DateTime")	AUTO	
>	CONTAINS	NUM	(113507, DCM, "Administered activity")	AUTO	
>	CONTAINS	INCLUDE	DTID 10023 "Organ Dose"	AUTO	One CONTAINER for each (Organ) Finding Site. See Table 186: TID 10023 Organ Dose
>	CONTAINS	CONTAINER	(220001, 99SHS, "Effective Dose Information")	AUTO	One CONTAINER. See Table 187: Private Codes used in Radiopharmaceutical Radiation Dose SR
>>	CONTAINS	NUM	(113839, DCM, "Effective Dose ")	AUTO	Unit (mSv, UCUM, "mSv")
>>	HAS PROPERTIES	TEXT	(121406, DCM, "Reference Authority")	AUTO	"ICRP Publication 128" for all Radiopharmaceuticals except N-13 Ammonia in which case value will be "ICRP Publication 53"
>	CONTAINS	CODE	(410675002, SCT, "Route of administration")	AUTO	
>	CONTAINS	INCLUDE	DTID 1020 "Person Participant"	AUTO	

9.3.2.2.3 TID 10024 Imaging Agent Administration Patient Characteristics

Table 184: TID 10024 Imaging Agent Administration Patient Characteristics

NL	Rel with Parent	VT	Concept Name	Presence	Values
		CONTAINER	(121118, DCM, "Patient Characteristics")	AUTO	
>	CONTAINS	NUM	(121033, DCM, "Subject Age")	MWL/USER	Unit (a, UCUM, "year")
>	CONTAINS	CODE	EV (121032, DCM, "Subject Sex")	MWL/USER	Use DCID 7455 "Sex"
>	CONTAINS	NUM	(8302-2, LN, "Patient Height")	MWL/USER	Unit (cm, UCUM, "cm")

NL	Rel with Parent	VT	Concept Name	Presence	Values
>	CONTAINS	NUM	(29463-7 ,LN, "Patient Weight")	MWL/USER	Unit (kg, UCUM, "kg")

9.3.2.2.4 TID 1020 Person Participant

Table 185: TID 1020 Person Participant

NL	Rel with Parent	VT	Concept Name	Presence	Values
	HAS OBS CONTEXT	PNAME	(113870, DCM, "Person Name")	AUTO	Always "Unknown" because the person doing the injection is not known by the system.
>	HAS PROPERTIES	CODE	(113875, DCM, "Person Role in Procedure")	AUTO	(113851, DCM, "Irradiation Administering")

9.3.2.2.5 TID 10023 Organ Dose

Table 186: TID 10023 Organ Dose

NL	Rel with Parent	VT	Concept Name	Presence	Values
		CONTAINER	(113517, DCM, "Organ Dose Information")	AUTO	
>	HAS CONCEPT MOD	CODE	(G-COE3, SRT, "Finding Site")	AUTO	See Error! Reference source not found. Table 175: Organs used for Reporting in Created PET RRDSR Instances
>	HAS CONCEPT MOD	CODE	(G-C171, SRT, "Laterality")	AUTO	Provided if Finding Site has a laterality See Error! Reference source not found. Table 175: Organs used for Reporting in Created PET RRDSR Instances
>	CONTAINS	NUM	(113518, DCM, "Organ Dose")	AUTO	Unit (mGy, UCUM, "mGy")
>>	HAS PROPERTIES	TEXT	(121406, DCM, "Reference Authority")	AUTO	"ICRP Publication 128" for all Radiopharmaceuticals except N-13 Ammonia in which case value will be "ICRP Publication 53"

9.3.3 Private Code Definitions

9.3.3.1 Private Codes in Radiopharmaceutical Radiation Dose SR

The following table shows private codes used in the PET Radiopharmaceutical Radiation Dose Report

Table 187: Private Codes used in Radiopharmaceutical Radiation Dose SR

Coding Scheme Designator (0008,0102)	Code Value (0008,0100)	Code Meaning (0008,0104)	Definition
99SHS	220001	Effective Dose Information	Effective dose estimate based on the injected dose

9.4 Grayscale Image Consistency

N/A

9.5 Standard Extended / Specialized / Private SOP Classes

For documentation of (private) module and attribute extensions of created SOP Instances please see 9.1.1 Created SOP Instance(s). Corresponding module and attribute extensions can be found for CT Image Storage SOP Class (see 0), Secondary Capture Image Storage SOP Class (see 9.1.1.3), X-Ray Radiation Dose SR Storage SOP Class (see 0), Radiopharmaceutical Radiation Dose SR Storage SOP Class (see 9.1.1.5), Comprehensive SR Storage SOP Class (see 9.1.1.5) and Positron Emission Tomography Image Storage SOP Class (see 9.1.1.8).

9.5.1 Standard Extensions

9.5.1.1 Standard Extensions for CT SOP Classes

The following tables list details of DICOM IOD attributes where the DICOM standard definitions are extended:

Table 188: Standard Extensions of CT SOP Classes

Attribute Name	Tag	Type	Notes
Image Type	(0008,0008)	1	<p>See Section 9.5.1.1.1 (Image Type) further explanation.</p> <p>additional Defined Terms for value 3:</p> <ul style="list-style-type: none"> OTHER MPR PROJECTION IMAGE UNDEFINED <p>Defined Terms for value 4:</p> <ul style="list-style-type: none"> CSA *¹ CT_SOM4 * CT_SOM5 * ECAT * SHS * <p>Biograph Vision provides a value 5 with the Defined Terms:</p> <ul style="list-style-type: none"> ADD CTL FINISHED IN_WORK MRTD OTOM OTOP PBF

¹ For terms beginning with the stated prefix, e. g. "CSA", and ending with a "*", see Chapter: 9.5.1.1.1 Image Type

Attribute Name	Tag	Type	Notes
			PBV PKET PMON STD TTP TTS Biograph Vision provides a value 6 with the Defined Terms: DNRG SNRG Biograph Vision provides a value 7 with the Defined Terms: DET_A DET_B
Body Part Examined	(0018,0015)	3	Additional Defined Terms for the PETSyngo based SOMATOM products: SPECIAL UNKNOWN SERVICE PARTIALBODY See section Body Part Examined for further explanation.

All SOP Classes may contain additional type 3 attributes which DICOM standard defines in a different DICOM IOD or DICOM SOP Class (attributes from Normalized SOP Classes).

This is the case for example for

- Rescale Slope (0028,1053)
- Rescale Intercept (0028,1052)

which are also used in the MR IOD.

9.5.1.1.1 Image Type

The Image Type (0008,0008) attribute identifies important image identification characteristics. These characteristics are:

1. Pixel Data Characteristics:
 - is the image an ORIGINAL Image; an image whose pixel values are based on original or source data, or
 - is the image a DERIVED Image; an image whose pixel values have been derived in some manner from the pixel value of one or more other images.
2. Patient Examination Characteristics:
 - is the image a PRIMARY Image; an image created as a direct result of the Patient examination, or
 - is the image a SECONDARY Image; an image created after the initial Patient examination.
3. Modality Specific Characteristics (SOP Specific Characteristics).
4. Implementation specific identifiers: other implementation specific identifiers shall be documented in an implementation's conformance claim.

The Image Type attribute is multi-valued and shall be provided in the following manner:

Value 1 shall identify the Pixel Data Characteristics; Enumerated Values for the Pixel Data Characteristics are:

- ORIGINAL = identifies an Original Image
- DERIVED = identifies a Derived Image

Value 2 shall identify the Patient Examination Characteristics; Enumerated Values for the Patient Examination Characteristics are:

- PRIMARY = identifies a Primary Image
- SECONDARY = identifies a Secondary Image

Value 3 shall identify any Image IOD specific specialization, the following terms are defined in addition to the DICOM standard definitions:

- OTHER = converted non-Axial and non-Localizer CT images; images of no special type (new syntax)
- MPR = 3D MPR images (MR)
- PROJECTION IMAGE = 3D MIP and SSD images (MR)
- UNDEFINED = images of no special type (old syntax)

Value 4 is implementation specific. The following terms are defined:

- original syngo generated data set types:
 - CSA 3D EDITOR = object created by 3D Editor
 - CSA 3D FLY PATH = object created by Fly Through Path
 - CSA 3D FLY VRT = object created by Fly Through Volume Rendering Technique
 - CSA 3D FUSION = object created by Fusion
 - CSA AVERAGE = image was created by Average
 - CSA BLACK IMAGE = SC Image with black pixels, only graphics information is of interest
 - CSA BOOKMARK = InSpace generated SC image containing bookmark information
 - CSA RESAMPLED = derived image created by zooming or panning original image
 - CSA REPORT = *syngo* Reporting (documentation of diagnosis)
 - CSA RESULT = *syngo* Reporting (post processing results)
 - CSA MIP = image created by Maximum Intensity Projection
 - CSA MIP THIN = image created by Maximum Intensity Projection
 - CSA MIP THIN CV = image created by Maximum Intensity Projection (curved cut)
 - CSA MPR = image created by Multi Planar Reconstruction
 - CSA MPR CV = image created by Multi Planar Reconstruction (curved cut)
 - CSA MPR THICK = image created by Multi Planar Reconstruction
 - CSA MPR THICK CV = image created by Multi Planar Reconstruction (curved cut)
 - CSA MPR THIN = image created by Multi Planar Reconstruction
 - CSA PSSD = SC image as Perspective Shaded Surface Display
 - CSA SSD = SC Image as Shaded Surface Display
 - CSA SUBTRACT = image was created by Subtraction
 - CSA VRT = SC Image created by Volume Rendering Technique
 - ECAT ACF = CTI PET Attenuation Correction
 - ECAT NORMAL = CTI PET Normalization
 - ECAT 3D SINO = CTI PET 3D Sinogram Short
 - ECAT 3D SINO FLT = CTI PET 3D Sinogram Float
- additional image types generated by Biograph Vision
 - CT_SOM5 AVE = Averaged Image
 - CT_SOM5 ICD = Interventional Cine Display Image
 - CT_SOM5 MON = Monitoring or Premonitoring Image

CT_SOM5 MUL = Multiscan Image
CT_SOM5 PAR = Parameter Image
CT_SOM5 PROT = Protocol Image
CT_SOM5 ROT = ROT Image
CT_SOM5 RTD = Real Time Display Image
CT_SOM5 SEQ = Sequence Image
CT_SOM5 SPI = Spiral Image
CT_SOM5 SPO = Spiral Oblique Image
CT_SOM5 STA = Static Image
CT_SOM5 SUB = Subtracted Image
CT_SOM5 TOP = Topogram
CT_SOM5 DPAN = Dental Panorama Rebuilt Tomogram
CT_SOM5 DPAR = Dental Paraxial Rebuilt Tomogram
CT_SOM5 DFLM = Dental Filming Image
CT_SOM5 DYB = Dynamic Evaluation Averaged Baseline Image
CT_SOM5 DYF = Dynamic Evaluation Fused Multislice Image
CT_SOM5 PEVI = Pulmo Evaluation Image
CT_SOM5 OEVA = Osteo Evaluated Tomogram
CT_SOM5 MIP = Maximum Intensity Projection image created by a CT application
CT_SOM5 MPR = Multi Planar Reconstruction image created by a CT application
CT_SOM5 REP = Lung Care Report Image

- converted images

CT_SOM4 NONE = converted SOMARIS image
CT_SOM4 CONV = converted SOMARIS Convolution Kernel file
CT_SOM4 DART = converted SOMARIS Dental Artificial image
CT_SOM4 DEVA = converted SOMARIS Dental Evaluation image
CT_SOM4 DGRA = converted SOMARIS Dental Graphics image
CT_SOM4 DMEA = converted SOMARIS Dynamic Measurement image
CT_SOM4 DPAN = converted SOMARIS Dental Panorama image
CT_SOM4 DPAR = converted SOMARIS Dental Paraxial image
CT_SOM4 EBT = converted SOMARIS Evolution image
CT_SOM4 HIS = converted SOMARIS Histogram Graphics image
CT_SOM4 HISC = converted SOMARIS Histogram Graphics image
CT_SOM4 MUL = converted SOMARIS Multiscan image
CT_SOM4 OEVA = converted SOMARIS Osteo Evaluation image
CT_SOM4 OTOM = converted SOMARIS Osteo Tomogram image
CT_SOM4 OTOP = converted SOMARIS Osteo Topogram image
CT_SOM4 PLOT = converted SOMARIS Plot image
CT_SOM4 QUAL = converted SOMARIS Quality image
CT_SOM4 R2D = converted SOMARIS 2D Rebuild image
CT_SOM4 R3D = converted SOMARIS 3D Rebuild image
CT_SOM4 R3DE = converted SOMARIS 3D Rebuild image
CT_SOM4 RMAX = converted SOMARIS Maximum Intensity Projection image
CT_SOM4 RMIN = converted SOMARIS Minimum Intensity Projection image
CT_SOM4 ROT = converted SOMARIS Rotation Mode image
CT_SOM4 RRAD = converted SOMARIS Radiographic Projection image
CT_SOM4 RVIT = converted SOMARIS Vessel Image Tool image

CT_SOM4 RVRT = converted SOMARIS Volumetric Rendering image
 CT_SOM4 SAVE = converted SOMARIS Evolution Screen Save image
 CT_SOM4 SCAN = converted SOMARIS Standard Mode image
 CT_SOM4 SEQ = converted SOMARIS Sequence Mode image
 CT_SOM4 SER = converted SOMARIS Serial Mode image
 CT_SOM4 SIN = converted SOMARIS Sinogram image
 CT_SOM4 SINC = converted SOMARIS Sinogram image
 CT_SOM4 SPI = converted SOMARIS Spiral Mode image
 CT_SOM4 STA = converted SOMARIS Static Mode image
 CT_SOM4 TAB = converted SOMARIS Correction Table image
 CT_SOM4 TOP = converted SOMARIS Topogram image
 CT_SOM4 GTOP = converted SOMARIS Topo Graphics image
 CT_SOM4 PEVG = converted SOMARIS Pulmo Evaluation image
 CT_SOM4 PEVI = converted SOMARIS Pulmo Evaluation image
 CT_SOM4 PUL = converted SOMARIS Pulmo Respiration curve
 CT_SOM4 PROT = converted SOMARIS Protocol image
 CT_SOM4 TEXT = converted SOMARIS Text image
 CT_SOM4 ICD = converted SOMARIS Interventional Cine image

SHS DENT = converted MagicView Dental Tomogram image
 SHS DPAN = converted MagicView Dental Panorama image
 SHS DPAR = converted MagicView Dental Paraxial image
 SHS 3D_CURVED = converted MagicView image
 SHS 3D_MIP = converted MagicView Maximum Intensity Projection image
 SHS 3D_MPR = converted MagicView Multi Planar Reconstruction image
 SHS 3D_SSD = converted MagicView Shaded Surface Display image
 SHS 3D_VRT = converted MagicView Volumetric Rendering image

Value 5 is specific for the Biograph Vision. In special cases (3D postprocessing) values mentioned for a lower index may appear for value 5 or higher. This will refer to 3D postprocessing base image types. The following terms are defined:

- ADD = Additional Scan
- ALP = Arterial Liver Perfusion
- AVG = Average
- BF = NeuroVPCT Blood Flow
- BFI = NeuroVPCT Blood Flow - IncGamma
- BV = NeuroVPCT Blood Volume
- BVP = NeuroVPCT Blood Volume - Patlak
- CBF = NeuroVPCT Blood Flow
- CBFA = NeuroVPCT Blood Flow - Alternate
- CBFI = NeuroVPCT Blood Flow - IncGamma
- CBV = NeuroVPCT Blood Volume
- CBVA = NeuroVPCT Blood Volume - Alternate
- CBVP = NeuroVPCT Blood Volume - Patlak
- CLA = Fast DE Results Classified volume
- CON = Fast DE Results Contour Enhancement volume
- CSQP = Patlak ChiSquare
- CTL = Control Scan
- HPI = Hepatic Perfusion Index
- FINISHED = Lung Care Report Image (finished)

- IN_WORK = Lung Care Report Image (not finished)
- MIP = Maximum Intensity Projection
- MIX = Fast DE Results Dual Energy image blended with a ratio of low kV and high kV image
- MRTD = Multiscan Real Time Display Image
- MTTA = Mean Transit Time – Alternate
- OTOM = Osteo Scanned Tomogram
- OTOP = Osteo Scanned Topogram
- PBF = Perfusion Blood Flow Image
- PBV = Perfusion Blood Volume Image
- PKET = Peak Enhancement Parameter Image
- PMBA = Permeability - Alternate
- PMBP = Permeability
- PMON = Premonitoring Scan
- PEAK = NeuroVPCT Peak Enhancement
- PVP = Portal Venous Liver Perfusion
- RSDP = Patlak Residual
- RSQP = Patlak RSquare
- RT3D CONFIG = InSpace Configuration Image
- STD = Standard image of corresponding Type 4
- TTDA = Time-to-Drain - Alternate
- TTP = Time-to-Peak Parameter Image
- TTS = Time-to-Start Parameter Image
- TTSA = NeuroVPCT Time-to-Start Parameter Image
- VNC = FAST DE Results Virtual Non-Contrast
- VPCT MCnFn = Motion Corrected, Filtered

Value 6 is specific to the Biograph Vision-based products. Dual Tube scans require a more detailed distinction.

The following terms are defined:

- DNRG = Dual Energy
- SNRG = Single Energy

Value 7 is specific to the Biograph Vision-based products. Dual Energy scans require a more detailed distinction.

The following terms are defined:

- DET_A = Only data of detector A used
- DET_B = Only data of detector B used
- DET_AB = Data is derived from detector A and detector B

Value 8 is specific to the Biograph Vision-based products. Preview images of SAFIRE/ADMIRE Reconstructions require the following term to be defined:

- IREC_PREVIEW

9.5.1.1.2 Body Part Examined

The Body Part Examined (0018,0015) attribute provides a textual description of the part of the body examined. The Biograph Vision extends the Defined Terms:

- SPINE = Summary term used instead of the Defined Terms CSPINE, TSPINE, LSPINE, and SSPINE
- SPECIAL = Image was acquired with acquisition modes that are not mapped to a certain part of the body
- SERVICE = Image was acquired for maintenance purpose
- UNKNOWN = No information about the body part available
- PARTIALBODY = Range used by PET Fast Planning

In addition, the user interface permits the definition of new terms by the user. So in fact any syntactically correct value may be present as a value of this attribute. It is recommended, though, to use the DICOM defined terms when appropriate.

9.5.1.1.3 RGB color images

The Biograph Vision DICOM application extends the CT Image IOD by the use of RGB color image description with the unsigned integer 24-bit color image plane pixel format:

- Samples per Pixel (attribute 0028, 0002) = 3
- Photometric Interpretation (attribute 0028,0004) = "RGB"
- Pixel Representation (attribute 0028, 0103) = 0
- Bits Allocated (attribute 0028, 0100) = 8
- Bits Stored (attribute 0028,0101) = 8
- High Bit (attribute 0028,0102) = 7
- Planar Configuration (attribute 0028,0006) = 0.

This format is used for Functional Imaging, i.e., images that meaningfully use all common CT Image attributes - however the pixel values do not represent a scaled Hounsfield value but a different value (depending on the type of image). Thus, window related attributes must not be used to interpret the pixel values as scaled HU. The values used by Biograph Vision are:

- Window Center (attribute 0028, 1050) = 128
- Window Width (attribute 0028,1051) = 256
- Rescale Intercept (attribute 0028, 1050) = 0
- Rescale Slope (attribute 0028,1051) = 1

The following types of images may use this format:

Table 189: Image Type (0008,0008) for objects created by Biograph Vision

Image Type Description	IOD	0008,0008 Value 1	0008,0008 Value 2	0008,0008 Value 3	0008,0008 Value 4	0008,0008 Value 5	Image Text
Averaged Image	CT	DERIVED	SECONDARY	AXIAL	CT_SOM5 AVE	none	AVE
Parameter Image (Patlak Blood Volume)	CT	DERIVED	SECONDARY	AXIAL	CT_SOM5 PAR	PKBV	PAR
Parameter Image (Peak enhancement)	CT	DERIVED	SECONDARY	AXIAL	CT_SOM5 PAR	PKET	PAR
Parameter Image (Perfusion Blood Flow)	CT	DERIVED	SECONDARY	AXIAL	CT_SOM5 PAR	PBF	PAR
Parameter Image (Perfusion Blood Volume)	CT	DERIVED	SECONDARY	AXIAL	CT_SOM5 PAR	PBV	PAR
Parameter Image (Permeability)	CT	DERIVED	SECONDARY	AXIAL	CT_SOM5 PAR	PMB	PAR
Parameter Image (Time to Peak)	CT	DERIVED	SECONDARY	AXIAL	CT_SOM5 PAR	TTP	PAR
Parameter Image (Time to Start)	CT	DERIVED	SECONDARY	AXIAL	CT_SOM5 PAR	TTS	PAR

Image Type Description	IOD	0008,0008 Value 1	0008,0008 Value 2	0008,0008 Value 3	0008,0008 Value 4	0008,0008 Value 5	Image Text
Parameter Image (Patlak Residual)	CT	DERIVED	SECONDARY	AXIAL	CT_SOM5 PAR	PKER	PAR
Parameter Image (Patlak RSquare)	CT	DERIVED	SECONDARY	AXIAL	CT_SOM5 PAR	PKR2	PAR
Parameter Image (Arterial Liver Perfusion)	CT	DERIVED	SECONDARY	AXIAL	CT_SOM5 PAR	ALP	PAR
Parameter Image (Portal Venous Liver Perfusion)	CT	DERIVED	SECONDARY	AXIAL	CT_SOM5 PAR	PVP	PAR
Parameter Image (Hepatic Perfusion Index)	CT	DERIVED	SECONDARY	AXIAL	CT_SOM5 PAR	HPI	PAR
LungCARE send-to-Filming images	CT	DERIVED	SECONDARY	OTHER	CSA MIP THIN	LC VALID WINDOW	MIP
LungCARE send-to-Filming images	CT	DERIVED	SECONDARY	OTHER	CSA MPR THICK	LC VALID WINDOW	MPR
LungCARE send-to-Filming images	CT	DERIVED	SECONDARY	OTHER	CSA VRT THIN	LC VALID WINDOW	VRT
LungCARE send-to-Filming images	CT	DERIVED	SECONDARY	OTHER	CSA PRVT	LC VALID WINDOW	PVRT
LungCARE send-to-Filming images	CT	DERIVED	SECONDARY	OTHER	CSA MPR	LC VALID WINDOW	MPR

9.5.1.2 Standard Extended Attributes for PET Image IOD

Table 190: Standard Extended Attributes for PET Image IOD

Name	Tag	Explanation
Procedure Code Sequence	(0008,1032)	Used for Siemens internal processing
>Code Value	(0008,0100)	Used for Siemens internal processing

>Coding Scheme Designator	(0008,0102)	Used for Siemens internal processing
>Code Meaning	(0008,0104)	Used for Siemens internal processing
Performed Protocol Code Sequence	(0040,0260)	Used for Siemens internal processing
>Code Value	(0008,0100)	Used for Siemens internal processing
>Coding Scheme Designator	(0008,0102)	Used for Siemens internal processing
>Code Meaning	(0008,0104)	Used for Siemens internal processing

9.5.1.3 PET Extensions for non-Image Objects

Biograph Vision uses the following Defined Terms for Image Type (0008,0008):

- Value 1: ORIGINAL, DERIVED
- Value 2: PRIMARY
- Value 3: PET_CALIBRATION, PETCT_SPL, PET_LISTMODE, PET_EM_SINOGRAM, PET_PHYSIO, PET_REPLAY_PARAM, PET_COUNTRATE
- Value 4: CARDIAC, RESPIRATORY, PET_PHYSIO_MFL

The following table lists the Biograph Vision non-image types and the corresponding values.

Table 191: Biograph Vision non-image Types

Description	0008,0008 Value 1	0008,0008 Value 2	0008,0008 Value 3	0008,0008 Value 4
Sinogram data	ORIGINAL	PRIMARY	PET_EM_SINOGRAM	none
Listmode data	ORIGINAL	PRIMARY	PET_LISTMODE	none or CARDIAC or RESPIRATORY
Attenuation correction data	DERIVED	PRIMARY	none	none
Norm data	ORIGINAL	PRIMARY	PET_CALIBRATION	none
Protocol data	ORIGINAL	PRIMARY	PETCT_SPL	none
Physiological data	ORIGINAL	PRIMARY	PET_PHYSIO	CARDIAC or RESPIRATORY or PET_PHYSIO_MFL
Replay parameters	ORIGINAL	PRIMARY	PET_REPLAY_PARAM	none
Count Rate Data	ORIGINAL	PRIMARY	PET_COUNTRATE	none
PET TAC Data	ORIGINAL	PRIMARY	PET_TAC_IF	none
Patient Position	ORIGINAL	PRIMARY	none	none

9.5.1.4 Extensions to the Basic Directory for Siemens Non-Image Objects

According to the PRI-SYNGO Application Profile Class the usage of the Private Creator UIDs and further optional keys for the Directory Records referring to SIEMENS Non-Image Objects are listed in the following table.

Table 192: Extensions to the Basic Directory for Siemens Non-Image Objects

Attribute	Tag	Value used
Private Record UID	(0004,1432)	1.3.12.2.1107.5.9.1
SOP Class UID	(0008,0016)	1.3.12.2.1107.5.9.1

For the Non-Images no Icon Image Sequence will be generated

9.5.1.5 Images Created by Biograph Vision

The following table lists the Biograph Vision image types and the corresponding combinations of the Image Type Attribute values.

Table 193: Image Type (0008,0008) for CT and SC objects created by Biograph Vision

Image Type Description [known creating applications]	IOD	0008,0008 Value 1	0008,0008 Value 2	0008,0008 Value 3	0008,0008 Value 4	0008,0008 Value 5	Image Text or Lists
Averaged Image [Average, DynEva, Perfusion]	CT	DERIVED	SECONDARY	AXIAL	CT_SOM5 AVE	none	AVE
Interventional Cine Display Image	CT	ORIGINAL	PRIMARY	AXIAL	CT_SOM5 ICD	none	ICD
Monitoring Image	CT	ORIGINAL	PRIMARY	AXIAL	CT_SOM5 MON	none	MON
Premonitoring Image	CT	ORIGINAL	PRIMARY	AXIAL	CT_SOM5 MON	PMON	MON
Multiscan Image	CT	ORIGINAL	PRIMARY	AXIAL	CT_SOM5 MUL	none	MUL
Parameter Image (Arterial Liver Perfusion) [BodyPerfusion]	CT	DERIVED	SECONDARY	AXIAL	CT_SOM5 PAR	ALP	PAR
Parameter Image (Hepatic Perfusion Index) [BodyPerfusion]	CT	DERIVED	SECONDARY	AXIAL	CT_SOM5 PAR	HPI	PAR
Parameter Image (Portal Venous Liver Perfusion) [BodyPerfusion]	CT	DERIVED	SECONDARY	AXIAL	CT_SOM5 PAR	PVP	PAR

Image Type Description [known creating applications]	IOD	0008,0008 Value 1	0008,0008 Value 2	0008,0008 Value 3	0008,0008 Value 4	0008,0008 Value 5	Image Text or Lists
Protocol Image, Time Density Curve Image [BodyPerfusion] ¹	SC	DERIVED	SECONDARY	OTHER	none	none	AC
Parameter Image (Patlak Blood Volume) [Perfusion]	CT	DERIVED	SECONDARY	AXIAL	CT_SOM5 PAR	PKBV	PAR
Parameter Image (Patlak Residual) [Perfusion]	CT	DERIVED	SECONDARY	AXIAL	CT_SOM5 PAR	PKER	PAR
Parameter Image (Patlak RSquare) [Perfusion]	CT	DERIVED	SECONDARY	AXIAL	CT_SOM5 PAR	PKR2	PAR
Parameter Image (Peak enhancement) [DynEva, Perfusion]	CT	DERIVED	SECONDARY	AXIAL	CT_SOM5 PAR	PKET	PAR
Parameter Image (Perfusion Blood Flow) [Perfusion]	CT	DERIVED	SECONDARY	AXIAL	CT_SOM5 PAR	PBF	PAR
Parameter Image (Perfusion Blood Volume) [Perfusion]	CT	DERIVED	SECONDARY	AXIAL	CT_SOM5 PAR	PBV	PAR
Parameter Image (Permeability) [Perfusion]	CT	DERIVED	SECONDARY	AXIAL	CT_SOM5 PAR	PMB	PAR
Parameter Image (Time to Peak) [DynEva, Perfusion]	CT	DERIVED	SECONDARY	AXIAL	CT_SOM5 PAR	TTP	PAR
Parameter Image (Time to Start) [Perfusion]	CT	DERIVED	SECONDARY	AXIAL	CT_SOM5 PAR	TTS	PAR

¹ More detailed attribute information will be provided in a future version.

Image Type Description [known creating applications]	IOD	0008,0008 Value 1	0008,0008 Value 2	0008,0008 Value 3	0008,0008 Value 4	0008,0008 Value 5	Image Text or Lists
Protocol Image	SC	DERIVED	SECONDARY	OTHER	CT_SOM5 PROT	none	PROT (List only)
Report Image (not finished)	SC	DERIVED	SECONDARY	OTHER	CT_SOM5 REP	IN_WORK	REP
Report Image (finished)	SC	DERIVED	SECONDARY	OTHER	CT_SOM5 REP	FINISHED	REP
ROT Image	CT	ORIGINAL	PRIMARY	AXIAL	CT_SOM5 ROT	none	ROT
Real Time Display Image	CT	ORIGINAL	PRIMARY	AXIAL	CT_SOM5 RTD	none	RTD
Real Time Display Image (Cardio)	CT	ORIGINAL	PRIMARY	AXIAL	CT_SOM5 RTD	STD	RTD
Multiscan Real Time Display Image	CT	ORIGINAL	PRIMARY	AXIAL	CT_SOM5 RTD	MRTD	RTD
Sequence Image	CT	ORIGINAL	PRIMARY / SECONDARY	AXIAL	CT_SOM5 SEQ	none	SEQ
Additional Scan Image	CT	ORIGINAL	PRIMARY / SECONDARY	AXIAL	CT_SOM5 SEQ	ADD	SEQ
Control Scan Image	CT	ORIGINAL	PRIMARY / SECONDARY	AXIAL	CT_SOM5 SEQ	CTL	SEQ
Spiral Image	CT	ORIGINAL	PRIMARY / SECONDARY	AXIAL	CT_SOM5 SPI	none	SPI
Spiral Image (Cardio)	CT	ORIGINAL	PRIMARY / SECONDARY	AXIAL	CT_SOM5 SPI	STD	SPI
Spiral Oblique Image	CT	DERIVED	PRIMARY / SECONDARY	AXIAL	CT_SOM5 SPO	none	SPO
Static Image	CT	ORIGINAL	PRIMARY	OTHER	CT_SOM5 STA	none	STA
Subtracted Image	CT	DERIVED	SECONDARY	AXIAL	CT_SOM5 SUB	none	SUB
Topogram	CT	ORIGINAL	PRIMARY	LOCALIZER	CT_SOM5 TOP	none	TOP

Image Type Description [known creating applications]	IOD	0008,0008 Value 1	0008,0008 Value 2	0008,0008 Value 3	0008,0008 Value 4	0008,0008 Value 5	Image Text or Lists
Osteo Scanned Tomogram	CT	ORIGINAL	PRIMARY	AXIAL	CT_SOM5 SEQ	OTOM	SEQ
Osteo Scanned Topogram	CT	ORIGINAL	PRIMARY	LOCALIZER	CT_SOM5 TOP	OTOP	TOP
Osteo Evaluated Tomogram	CT	DERIVED	SECONDARY	AXIAL	CT_SOM5 OEVA	none	OEVA
Pulmo Evaluated Tomogram	CT	DERIVED	SECONDARY	AXIAL	CT_SOM5 PEVI	none	PEVI
Calcium Scoring Table [Calcium Scoring]	SC	DERIVED	SECONDARY	OTHER	CT_SOM5 TAB	none	TAB
Dental Filming Image	CT	DERIVED	SECONDARY	OTHER	CT_SOM5 DFLM	none	DFLM
Dental Panorama Rebuild Tomogram	CT	DERIVED	SECONDARY	OTHER	CT_SOM5 DPAN	none	DPAN
Dental Paraxial Rebuild Tomogram	CT	DERIVED	SECONDARY	OTHER	CT_SOM5 DPAR	none	DPAR
Dental/Volume Maximum Intensity Projection Image [Dental, Volume, DynEva, Perfusion]	CT	DERIVED	SECONDARY	AXIAL	CT_SOM5 MIP	none	MIP
Dental Panorama Reference Image [Dental, Volume]	CT	DERIVED	SECONDARY	AXIAL	CT_SOM5 MPR	none	MPR
Dental Paraxial Reference Image	CT	DERIVED	SECONDARY	AXIAL	CT_SOM5 MPR	none	MPR
Dental Reference Image	CT	DERIVED	SECONDARY	AXIAL	CT_SOM5 MPR	none	MPR
Dynamic Evaluation Averaged Baseline	CT	DERIVED	SECONDARY	AXIAL	CT_SOM5 DYB	none	DYB

Image Type Description [known creating applications]	IOD	0008,0008 Value 1	0008,0008 Value 2	0008,0008 Value 3	0008,0008 Value 4	0008,0008 Value 5	Image Text or Lists
Dynamic Evaluation Fused Multislice	CT	DERIVED	SECONDARY	AXIAL	CT_SOM5 DYF	none	DYF
Volume reformatted images (sagittal and coronal)	CT	DERIVED	SECONDARY	OTHER	CT_SOM5 MPR	none	MPR
Various result images [CalciumScoring, Colon]	CT	DERIVED	SECONDARY	AXIAL	CSA MPR	none	MPR
Various result images	CT	DERIVED	SECONDARY	AXIAL	CSA MPR THICK	none	MPR
Various result images	CT	DERIVED	SECONDARY	AXIAL	CSA MIP	none	MIP
Various result images [CalciumScoring]	CT	DERIVED	SECONDARY	AXIAL	CSA MIP THIN	none	MIP
Various result images [Colon]	SC	DERIVED	SECONDARY	OTHER	CSA PSSD	none	PSSD
Various result images	CT	DERIVED	SECONDARY	AXIAL	CSA VRT	none	VRT
Various result images [Colon]	SC	DERIVED	SECONDARY	OTHER	CSA VRT	none	VRT
InSpace bookmark [InSpace]	SC	DERIVED	SECONDARY	OTHER	CSA BOOKMARK	RT3D CONFIG	BOOK
InSpace result images [InSpace]	SC	DERIVED	SECONDARY	OTHER	CSA 3DPROJECTI ON	none	3DPR
LungCARE save images [LungCARE]	SC	DERIVED	SECONDARY	OTHER	MIP	LC VALID WINDOW	MIP
LungCARE save images [LungCARE]	SC	DERIVED	SECONDARY	OTHER	MPR	LC VALID WINDOW	MPR

Image Type Description [known creating applications]	IOD	0008,0008 Value 1	0008,0008 Value 2	0008,0008 Value 3	0008,0008 Value 4	0008,0008 Value 5	Image Text or Lists
LungCARE save images [LungCARE]	SC	DERIVED	SECONDARY	OTHER	VRT	LC VALID WINDOW	VRT
LungCARE save images [LungCARE]	SC	DERIVED	SECONDARY	OTHER	PVRT	LC VALID WINDOW	PVRT
LungCARE save images [LungCARE]	CT	DERIVED	SECONDARY	OTHER	MPR	LC VALID WINDOW	MPR
LungCARE save images [LungCARE]	CT	DERIVED	SECONDARY	OTHER	CT_SOM5 SPI	LC VALID WINDOW	SPI
LungCARE report images [LungCARE]	SC	DERIVED	SECONDARY	OTHER	MIP	LC VALID WINDOW	none
LungCARE report images [LungCARE]	SC	DERIVED	SECONDARY	OTHER	MPR	LC VALID WINDOW	none
LungCARE report images [LungCARE]	SC	DERIVED	SECONDARY	OTHER	VRT	LC VALID WINDOW	none
LungCARE report images [LungCARE]	SC	DERIVED	SECONDARY	OTHER	PVRT	LC VALID WINDOW	none
Various Graphics [DynEva, Osteo, Pulmo, Volume, Perfusion, Argus]	SC	DERIVED	SECONDARY	OTHER	CSA BLACK IMAGE	none	none

Note

Some applications will create Structured Reports. However, when running in specific (service configured) settings outside of the system they will appear as a SC image, labelled as Type 3 "OTHER" and Type 4 "CSA REPORT". This private extension is not published in detail here because the intended use is real DICOM SR.

For Protocol Image, some additional information about DOSE INFO is added into Application Header Sequence(0029,xx40), more info about this Sequence see 9.1.1.1.6.

9.5.1.6 Structured Reports created by Biograph Vision

The following table lists the Biograph Vision image types and the corresponding combinations of the Image Type Attribute values.

Table 194: Image Type (0008,0008) for DICOM SR objects created by Biograph Vision

Image Type Description [known creating applications]	IOD	0008,0008 Value 1	0008,0008 Value 2	0008,0008 Value 3	0008,0008 Value 4	0008,0008 Value 5	Image Text or Lists
LungCARE SR reports [LungCARE, Calcium Scoring, Circulation]	SR	ORIGINAL	PRIMARY	OTHER	CSA REPORT	none	none

LungCARE, Calcium Scoring and Circulation create Comprehensive Structured Reports.

The following is valid for Calcium Scoring created Structured Reports:

CaScoring creates structured reports generally following the templates TID2000.

The following is valid for Circulation created Structured Reports:

Circulation creates structured reports generally following the DICOM template TID3900 defined in DICOM supplement 97 "CT/MR Cardiovascular Analysis Report" (Version: 0.11; Working Draft). Some changes of these templates that could not be considered may occur until document is released as final version.

Somar systems create CT Radiation Dose Structured Reports as a default configuration for every patient when he/she finishes measurement. (user can disable this function.)

X-Ray Radiation Dose SR generally follows the templates defined in DICOM Standard.

The following is valid for X-Ray Radiation Dose SR: X-Ray Radiation Dose SR follows the DICOM template TID10011.

9.5.1.7 Somaris Attribute Interpretation

N/A

9.5.1.8 OOG, Overlays, High Bit

Graphics in Biograph Vision images are stored as Object Oriented Graphics (OOG) in private attributes (see MEDCOM OOG Module). Non *syngo* based systems are not expected to interpret this information.

In order to allow display access to graphics information for DICOM based systems private OOG information is converted on export into DICOM Overlay information stored in group 6000. This is the recommended way for a DICOM based system to access overlay graphics information.

The following attributes are generated:

- Overlay Rows (6000,0010)
- Overlay Columns (6000,0011)
- Number of Frames in Overlay (6000,0015)
- Overlay Description (6000,0022) = "Siemens MedCom Object Graphics"
- Overlay Type (6000,0040) = "G"

- Origin (6000,0050) = 1, 1
- Image Frame Origin (6000,0051)
- Overlay Bits Allocated (6000,0100)
- Bit Position (6000,0102)
- Overlay Data (6000,3000)

However, DICOM Overlay information stored in group 6000 is not supported by all systems that might be used to store Biograph Vision images. These systems may not be able to display Biograph Vision generated overlays. For a special group of these systems there is another way to provide graphical overlay information. A remote node can be configured to have overlay graphics converted into unused pixel data above High Bit (0028,0102) for images that fulfil the following condition:

- Bits Allocated (attribute 0028, 0100) = 16
- Bits Stored (attribute 0028,0101) = 12
- High Bit (attribute 0028,0102) = 11

Some systems are known to support this coding; they are able to display this information with the images. Please note, however, that the proper and recommended way to store overlays with DICOM is the use of group 6000.

9.5.2 Specializations

N/A

9.5.3 Private SOP Classes

9.5.3.1 Private SOP Class CSA Non-Image

This section includes the definition of the Siemens AG B Med CSA defined private Non-Image Object (called CsaNonImage IOD). The focus of this private Non-Image Object is to address the requirement for non-image data sets found in *syngo* based applications. The CSA Non-Image IOD uses the following SOP Class.

Table 195: SOP Class UID for CSA Non-Image Objects

SOP Class Name	SOP Class UID
CSA Non-Image	1.3.12.2.1107.5.9.1

The MedCom Non-Image Information Object Definition specifies data sets that are converted from a non-DICOM format to a modality independent DICOM format.

Examples of such manufacturer model dependent data sets are:

- Raw Data
- CT Admin Data
- MR Spectroscopy Data
- etc.

9.5.3.1.1 CSA Non-Image IOD Entity Relationship Model

The E-R model in [DICOM] A.1.2 depicts those components of the DICOM Information Model which directly refer to the CSA Non-Image IOD. The frame of reference IE, overlay IE, modality look up table IE, VOI lookup table IE and curve IE are not components of the CSA Non-Image IOD.

Figure 12 DICOM Information Model

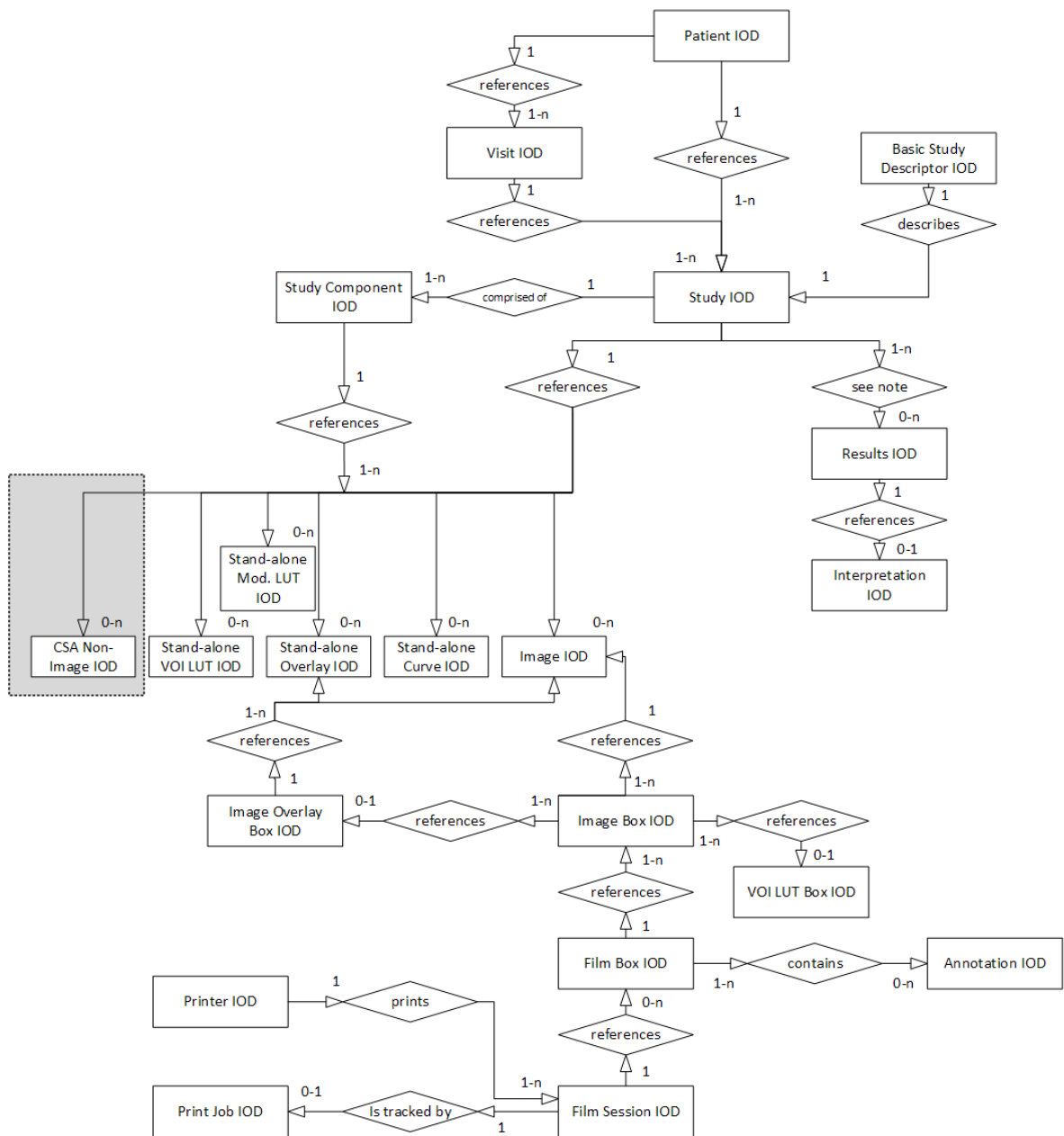

9.5.3.1.2 CT Extensions of the Non-Image Object

Biograph Vision uses the following defined term for Image Type (0008,0008):

- Value 1: ORIGINAL
- Value 2: PRIMARY
- Value 3: AXIAL, LOCALIZER, OTHER
- Value 4: a CT_SOM5 * enumeration
- Value 5: Biograph Vision specific enumeration

The following table lists the Biograph Vision non-image types and the corresponding combinations of the Image Type Attribute values.

Table 196: (Non-)Image Type (0008,0008) for private Biograph Vision Non-image Objects

Description	0008,0008 Value 1	0008,0008 Value 2	0008,0008 Value 3	0008,0008 Value 4	0008,0008 Value 5
CAD Results	DERIVED	SECONDARY	OTHER	CAD MARKS	none
Colonography Data	DERIVED	SECONDARY	OTHER	CT_SOM5 COL	none
Coronary Tree	DERIVED	SECONDARY	OTHER	CT_CIRCULATION	none
Raw Data	Same entries as for images				

9.6 Private Transfer Syntaxes

N/A

9.7 DICOM Print SCU - detailed status displays

The following tables document the behavior of the Biograph Vision DICOM Print AE in response to messages received for the printer SOP Class and the print job SOP Class.

Definitions of camera symbols:

- Idle: Camera is installed and ready; idle icon is displayed.
- Interact: The user has to react in near future, but not immediately.
Example: A camera was low in 8x10 clear sheets: LOW 8x10 CLR was sent by N-EVENT-REPORT.
- Queue Stopped: The user has to react immediately. Either the camera needs immediate interaction, or a job has been aborted.
Example: A camera is out of 8x10 clear sheets, or camera is down, or a film job is aborted.

Note: Different camera symbols are displayed according to the Printer Status Info.

Table 197: Printer Status Infos within Printer SOP Class/Execution Status Infos within Print Job SOP Class

Printer Status info/Execution Status info	Description	Message string visible in the Status Bar	Other action for UI/camera symbol
NORMAL	Camera is ready.	Camera is ready.	<None>/idle
BAD RECEIVE MGZ	There is a problem with the film receive magazine. Films from the printer cannot be transported into the magazine.	Problem with receive magazine.	<None>/interact
BAD SUPPLY MGZ	There is a problem with a film supply magazine. Films from this magazine cannot be transported into the printer.	Problem with supply magazine.	<None>/interact

Printer Status info/Execution Status info	Description	Message string visible in the Status Bar	Other action for UI/camera symbol
CALIBRATING	Printer is performing self-calibration; it is expected to be available for normal operation shortly.	Self-calibration. Please wait.	<None>/idle
CALIBRATION ERR	An error in the printer calibration has been detected, quality of processed films may not be optimal.	Problem in calibration. Film quality may not be optimal.	<None>/interact
CHECK CHEMISTRY	A problem with the processor chemicals has been detected, quality of processed films may not be optimal.	Problem with chemistry. Film quality may not be optimal.	<None>/interact
CHECK SORTER	There is an error in the film sorter	Error in film sorter.	<None>/interact
CHEMICALS EMPTY	There are no processing chemicals in the processor, films will not be printed and processed until the processor is back to normal.	Camera chemistry empty. Please check.	<None>/interact
CHEMICALS LOW	The chemical level in the processor is low, if not corrected, it will probably shut down soon.	Camera chemistry low. Please check.	<None>/interact
COVER OPEN	One or more printer or processor covers, drawers, doors are open.	Camera cover, drawer or door open.	<None>/interact
ELEC CONFIG ERR	Printer configured improperly for this job.	Camera configured improperly for this job. Queue stopped.	Queue for this camera will be STOPPED/Queue stopped
ELEC DOWN	Printer is not operating due to some unspecified electrical hardware problem.	Camera electrical hardware problem.	<None>/interact
ELEC SW ERROR	Printer not operating for some unspecified software error.	Camera software problem. Queue stopped.	Queue for this camera will be STOPPED/queue stopped
EMPTY 8x10	The 8x10 inch film supply magazine is empty.	8x10 film supply empty.	<None>/interact
EMPTY 8x10 BLUE	The 8x10 inch blue film supply magazine is empty.	8x10 blue film supply empty.	<None>/interact

Printer Status info/Execution Status info	Description	Message string visible in the Status Bar	Other action for UI/camera symbol
EMPTY 8x10 CLR	The 8x10 inch clear film supply magazine is empty.	8x10 clear film supply empty.	<None>/interact
EMPTY 8x10 PAPER	The 8x10 inch paper supply magazine is empty.	8x10 paper supply empty.	<None>/interact
EMPTY 10x12	The 10x12 inch film supply magazine is empty.	10x12 film supply empty.	<None>/interact
EMPTY 10x12 BLUE	The 10x12 inch blue film supply magazine is empty.	10x12 blue film supply empty.	<None>/interact
EMPTY 10x12 CLR	The 10x12 inch clear film supply magazine is empty.	10x12 clear film supply empty.	<None>/interact
EMPTY 10x12 PAPER	The 10x12 inch paper supply magazine is empty.	10x12 paper supply empty.	<None>/interact
EMPTY 10x14	The 10x14 inch film supply magazine is empty.	10x14 film supply empty.	<None>/interact
EMPTY 10x14 BLUE	The 10x14 inch blue film supply magazine is empty.	10x14 blue film supply empty.	<None>/interact
EMPTY 10x14 CLR	The 10x14 inch clear film supply magazine is empty.	10x14 clear film supply empty.	<None>/interact
EMPTY 10x14 PAPER	The 10x14 inch paper supply magazine is empty.	10x14 paper supply empty.	<None>/interact
EMPTY 11x14	The 11x14 inch film supply magazine is empty.	11x14 film supply empty.	<None>/interact
EMPTY 11x14 BLUE	The 11x14 inch blue film supply magazine is empty.	11x14 blue film supply empty.	<None>/interact
EMPTY 11x14 CLR	The 11x14 inch clear film supply magazine is empty.	11x14 clear film supply empty.	<None>/interact
EMPTY 11x14 PAPER	The 11x14 inch paper supply magazine is empty.	11x14 paper supply empty.	<None>/interact
EMPTY 14x14	The 14x14 inch film supply magazine is empty.	14x14 film supply empty.	<None>/interact
EMPTY 14x14 BLUE	The 14x14 inch blue film supply magazine is empty.	14x14 blue film supply empty.	<None>/interact
EMPTY 14x14 CLR	The 14x14 inch clear film supply magazine is empty.	14x14 clear film supply empty.	<None>/interact
EMPTY 14x14 PAPER	The 14x14 inch paper supply magazine is empty.	14x14 paper supply empty.	<None>/interact
EMPTY 14x17	The 14x17 inch film supply magazine is empty.	14x17 film supply empty.	<None>/interact

Printer Status info/Execution Status info	Description	Message string visible in the Status Bar	Other action for UI/camera symbol
EMPTY 14x17 BLUE	The 14x17 inch blue film supply magazine is empty.	14x17 blue film supply empty.	<None>/interact
EMPTY 14x17 CLR	The 14x17 inch clear film supply magazine is empty.	14x17 clear film supply empty.	<None>/interact
EMPTY 14x17 PAPR	The 14x17 inch paper supply magazine is empty.	14x17 paper supply empty.	<None>/interact
EMPTY 24x24	The 24x24 inch film supply magazine is empty.	24x24 film supply empty.	<None>/interact
EMPTY 24x24 BLUE	The 24x24 inch blue film supply magazine is empty.	24x24 blue film supply empty.	<None>/interact
EMPTY 24x24 CLR	The 24x24 inch clear film supply magazine is empty.	24x24 clear film supply empty.	<None>/interact
EMPTY 24x24 PAPR	The 24x24 inch paper supply magazine is empty.	24x24 paper supply empty.	<None>/interact
EMPTY 24x30	The 24x30 inch film supply magazine is empty.	24x30 film supply empty.	<None>/interact
EMPTY 24x30 BLUE	The 24x30 inch blue film supply magazine is empty.	24x30 blue film supply empty.	<None>/interact
EMPTY 24x30 CLR	The 24x30 inch clear film supply magazine is empty.	24x30 clear film supply empty.	<None>/interact
EMPTY 24x30 PAPR	The 24x30 inch paper supply magazine is empty.	24x30 paper supply empty.	<None>/interact
EMPTY A4 PAPR	The A4 paper supply magazine is empty.	A4 paper supply empty.	<None>/interact
EMPTY A4 TRANS	The A4 transparency supply magazine is empty.	A4 transparency supply empty.	<None>/interact
EXPOSURE FAILURE	The exposure device has failed due to some unspecified reason.	Exposure device has failed.	<None>/interact
FILM JAM	A film transport error has occurred, and a film is jammed in the printer or processor.	Film jam.	<None>/interact
FILM TRANSP ERR	There is a malfunction with the film transport, there may or may not be a film jam.	Film transport problem.	<None>/interact
FINISHER EMPTY	The finisher is empty.	Finisher is empty.	<None>/interact

Printer Status info/Execution Status info	Description	Message string visible in the Status Bar	Other action for UI/camera symbol
FINISHER ERROR	The finisher is not operating due to some unspecified reason.	Finisher problem.	<None>/interact
FINISHER LOW	The finisher is low on supplies	Finisher low.	<None>/interact
LOW 8x10	The 8x10 inch film supply magazine is low.	8x10 film supply low.	<None>/interact
LOW 8x10 BLUE	The 8x10 inch blue film supply magazine is low.	8x10 blue film supply low.	<None>/interact
LOW 8x10 CLR	The 8x10 inch clear film supply magazine is low.	8x10 clear film supply low.	<None>/interact
LOW 8x10 PAPER	The 8x10 inch paper supply magazine is low.	8x10 paper supply low.	<None>/interact
LOW 10x12	The 10x12 inch film supply magazine is low.	10x12 film supply low.	<None>/interact
LOW 10x12 BLUE	The 10x12 inch blue film supply magazine is low.	10x12 blue film supply low.	<None>/interact
LOW 10x12 CLR	The 10x12 inch clear film supply magazine is low.	10x12 clear film supply low.	<None>/interact
LOW 10x12 PAPER	The 10x12 inch paper supply magazine is low.	10x12 paper supply low.	<None>/interact
LOW 10x14	The 10x14 inch film supply magazine is low.	10x14 film supply low.	<None>/interact
LOW 10x14 BLUE	The 10x14 inch blue film supply magazine is low.	10x14 blue film supply low.	<None>/interact
LOW 10x14 CLR	The 10x14 inch clear film supply magazine is low.	10x14 clear film supply low.	<None>/interact
LOW 10x14 PAPER	The 10x14 inch paper supply magazine is low.	10x14 paper supply low.	<None>/interact
LOW 11x14	The 11x14 inch film supply magazine is low.	11x14 film supply low.	<None>/interact
LOW 11x14 BLUE	The 11x14 inch blue film supply magazine is low.	11x14 blue film supply low.	<None>/interact
LOW 11x14 CLR	The 11x14 inch clear film supply magazine is low.	11x14 clear film supply low.	<None>/interact
LOW 11x14 PAPER	The 11x14 inch paper supply magazine is low.	11x14 paper supply low.	<None>/interact

Printer Status info/Execution Status info	Description	Message string visible in the Status Bar	Other action for UI/camera symbol
LOW 14x14	The 14x14 inch film supply magazine is low.	14x14 film supply low.	<None>/interact
LOW 14x14 BLUE	The 14x14 inch blue film supply magazine is low.	14x14 blue film supply low.	<None>/interact
LOW 14x14 CLR	The 14x14 inch clear film supply magazine is low.	14x14 clear film supply low.	<None>/interact
LOW 14x14 PAPER	The 14x14 inch paper supply magazine is low.	14x14 paper supply low.	<None>/interact
LOW 14x17	The 14x17 inch film supply magazine is low.	14x17 film supply low.	<None>/interact
LOW 14x17 BLUE	The 14x17 inch blue film supply magazine is low.	14x17 blue film supply low.	<None>/interact
LOW 14x17 CLR	The 14x17 inch clear film supply magazine is low.	14x17 clear film supply low.	<None>/interact
LOW 14x17 PAPER	The 14x17 inch paper supply magazine is low.	14x17 paper supply low.	<None>/interact
LOW 24x24	The 24x24 inch film supply magazine is low.	24x24 film supply low.	<None>/interact
LOW 24x24 BLUE	The 24x24 inch blue film supply magazine is low.	24x24 blue film supply low.	<None>/interact
LOW 24x24 CLR	The 24x24 inch clear film supply magazine is low.	24x24 clear film supply low.	<None>/interact
LOW 24x24 PAPER	The 24x24 inch paper supply magazine is low.	24x24 paper supply low.	<None>/interact
LOW 24x30	The 24x30 inch film supply magazine is low.	24x30 film supply low.	<None>/interact
LOW 24x30 BLUE	The 24x30 inch blue film supply magazine is low.	24x30 blue film supply low.	<None>/interact
LOW 24x30 CLR	The 24x30 inch clear film supply magazine is low.	24x30 clear film supply low.	<None>/interact
LOW 24x30 PAPER	The 24x30 inch paper supply magazine is low.	24x30 paper supply low.	<None>/interact
LOW A4 PAPER	The A4 paper supply magazine is low.	A4 paper supply low.	<None>/interact
LOW A4 TRANS	The A4 transparency supply magazine is low.	A4 transparency supply low.	<None>/interact
NO RECEIVE MGZ	The film receive magazine no available.	Film receiver not available.	<None>/interact

Printer Status info/Execution Status info	Description	Message string visible in the Status Bar	Other action for UI/camera symbol
NO RIBBON	The ribbon cartridge needs to be replaced.	Replace ribbon cartridge.	<None>/interact
NO SUPPLY MGZ	The film supply magazine specified for this job is not available.	Film supply not available.	<None>/interact
CHECK PRINTER	The printer is not ready at this time, operator intervention is required to make the printer available.	Check camera.	<None>/interact
CHECK PROC	The processor is not ready at this time, operator intervention is required to make the printer available.	Check processor.	<None>/interact
PRINTER DOWN	The printer is not operating due to some unspecified reason.	Camera down.	<None>/interact
PRINTER INIT	The printer is not ready at this time, it is expected to become available without intervention, for example, it may be in a normal warm-up state.	Camera initializing.	<None>/idle
PRINTER OFFLINE	The printer has been disabled by an operator or service person.	Camera off-line.	<None>/interact
PROC DOWN	The processor is not operating due to some unspecified reason.	Processor down.	<None>/interact
PROC INIT	The processor is not ready at this time, it is expected to become available without intervention. For example, it may be in a normal warm-up state.	Processor initializing.	<None>/idle
PROC OVERFLOW FL	Processor chemicals are approaching the overflow full mark.	Processor chemicals overflow.	<None>/interact
PROC OVERFLOW HI	Processor chemicals have reached the overflow full mark.	Processor chemicals near overflow.	<None>/interact
QUEUED	Print job in Queue	-	<None>/idle
RECEIVER FULL	The Film receive magazine is full.	Receiver full.	<None>/interact

Printer Status info/Execution Status info	Description	Message string visible in the Status Bar	Other action for UI/camera symbol
REQ MED NOT INST	The requested film, paper, or other media supply magazine is installed in the printer but may be available with operator intervention.	Install media supply.	<None>/interact
REQ MED NOT AVAI	The requested film, paper, or other media requested is not available on this printer.	Media supply not available on this camera. Queue stopped. Change camera.	Queue for this camera will be STOPPED/queue stopped
RIBBON ERROR	There is an unspecified problem with the print ribbon.	Error with print ribbon.	<None>/interact
SUPPLY EMPTY	The printer is out of film.	Camera out of film.	<None>/interact
SUPPLY LOW	The film supply is low.	Film supplies low.	<None>/interact
UNKNOWN	There is an unspecified problem.	Unspecified problem with camera.	<None>/interact

Table 198: Printer Status Infos: Additional Agfa printer status infos

Printer Status info	Description	Message string visible in the Status Bar	Other action for syngo/camera symbol
WARMING UP	Printer is in the warm-up stage. Spooling of print jobs to disk is still possible.	Camera is warming up.	<None>idle
OFFLINE	Printer is switched off-line. Spooling of print jobs to disk is still possible.	Camera is switched off-line.	<None>/interact
NONE	General printer warning, no specific information is available. Spooling of print jobs to disk is still possible.	-	<None>/idle

Table 199: Printer Status Infos: Additional Kodak infos for PACS Link (formerly Imation cameras)

Printer Status info	Description	Message string visible in the Status Bar	Other action for syngo/camera symbol
SUPPLY MGZ ERR	The supply magazine has an error.	Film supply has an error.	<None>/interact

Table 200: Printer Status Infos: Additional Kodak infos for Kodak 190

Printer Status info	Description	Message string visible in the Status Bar	Other action for syngo /camera symbol
PRINTER STOPPED	The printer has stopped	Camera has stopped.	<None>/interact
FATAL ERROR	Fatal error.	Fatal error. Queue stopped.	Queue for this camera will be STOPPED/queue stopped

Table 201: Printer Status Infos: Additional Kodak infos for 2180/1120

Printer Status info	Description	Message string visible in the Status Bar	Other action for syngo/camera symbol
PRINTER NOT RDY	Printer not ready.	Camera not ready.	<None>/interact
CHECK PROCESSOR	Check processor.	Check processor.	<None>/interact
NO TONER	No toner.	No toner.	<None>/interact
FATAL	Fatal error.	Fatal error. Queue stopped.	Queue for this camera will be STOPPED/queue stopped

Table 202: Printer Status Infos: Additional Codonics infos

Printer Status info	Description	Message string visible in the Status Bar	Other action for syngo/camera symbol
STANDARD	Printer is ready.	Camera is ready.	<None>/Normal
LOAD A-SIZE	Load A-size media.	Load A-size media.	<None>/interact
LOAD A-DVPAPER	Load A-size black and white paper.	Load A-size black and white paper.	<None>/interact
LOAD A-CVPAPER	Load A-size color paper.	Load A-size color paper.	<None>/interact
LOAD A-CVTRANS	Load A-size transparencies.	Load A-size transparencies.	<None>/interact
LOAD A4-SIZE	Load A4-size media.	Load A4-size media.	<None>/interact
LOAD A4-DVPAPER	Load A4-size black and white paper.	Load A4-size black and white paper.	<None>/interact
LOAD A4-CVPAPER	Load A4-size color paper.	Load A4-size color paper.	<None>/interact

Printer Status info	Description	Message string visible in the Status Bar	Other action for syngo/camera symbol
LOAD A4-CVTRANS	Load A4-size transparencies.	Load A4-size transparencies.	<None>/interact
LOAD LA-SIZE	Load LA-size media.	Load LA-size media.	<None>/interact
LOAD LA-DVPAPER	Load LA-size black and white paper.	Load LA-size black and white paper.	<None>/interact
LOAD LA-CVPAPER	Load LA-size color paper.	Load LA-size color paper.	<None>/interact
LOAD LA-CVTRANS	Load LA-size transparencies.	Load LA-size transparencies.	<None>/interact
LOAD LA4-SIZE	Load LA4-size media.	Load LA4-size media.	<None>/interact
LOAD LA4-DVPAPER	Load LA4-size black and white paper.	Load LA4-size black and white paper.	<None>/interact
LOAD LA4-CVPAPER	Load LA4-size color paper.	Load LA4-size color paper.	<None>/interact
LOAD LA4-CVTRANS	Load LA4-size transparencies.	Load LA4-size transparencies.	<None>/interact
LOAD XLA-SIZE	Load XLA-size media.	Load XLA-size media.	<None>/interact
LOAD XLA-DVPAPER	Load XLA-size black and white paper.	Load XLA-size black and white paper.	<None>/interact
LOAD XLA-CVPAPER	Load XLA-size color paper.	Load XLA-size color paper.	<None>/interact
LOAD XLA-CVTRANS	Load XLA-size transparencies.	Load XLA-size transparencies.	<None>/interact
LOAD XLA4-SIZE	Load XLA4-size media.	Load XLA4-size media.	<None>/interact
LOAD XLA4-DVPAPE	Load XLA4-size black and white paper.	Load XLA4-size black and white paper.	<None>/interact
LOAD XLA4-CVPAPE	Load XLA4-size color paper.	Load XLA4-size color paper.	<None>/interact
LOAD XLA4-CVTRAN	Load XLA4-size transparencies.	Load XLA4-size transparencies.	<None>/interact
LOAD XLW-SIZE	Load XLW-size media.	Load XLW-size media.	<None>/interact
LOAD XLW-DVPAPER	Load XLW-size black and white paper.	Load XLW-size black and white paper.	<None>/interact

Printer Status info	Description	Message string visible in the Status Bar	Other action for syngo/camera symbol
LOAD XLW-CVPAPER	Load XLW-size color paper.	Load XLW-size color paper.	<None>/interact
LOAD 8X10-SIZE	Load 8x10 media.	Load 8x10 media.	<None>/interact
LOAD 8X10-DVFILM	Load 8x10 black and white film.	Load 8x10 black and white film.	<None>/interact
SUPPLY MISSING	The film supply magazine specified for this job is not available.	Film supply not available.	<None>/interact
RIBBON MISSING	Ribbon is missing.	Ribbon is missing.	<None>/interact
RIBBON EMPTY	Ribbon is empty.	Ribbon is empty.	<None>/interact
TOP COVER OPEN	Top cover of printer is open.	Top cover of camera is open.	<None>/interact

Table 203: Additional DICOM Execution Status Information - evaluation

Execution Status info	Description	Message string visible in the Status Bar	Other action for syngo /camera symbol
INVALID PAGE DES	The specified page layout cannot be printed, or other page description errors have been detected.	Film Job cannot be printed on this camera. Queue stopped. Please redirect film job.	Queue for this camera will be STOPPED/queue stopped
INSUFFIC MEMORY	There is not enough memory available to complete this job.	Not enough memory available in camera. Queue stopped. Please continue queue or change camera.	Queue for this camera will be STOPPED/queue stopped
NONE	General printer warning, no specific information is available. Spooling of print jobs to disk is still possible.	-	<None>/idle

Additional DICOM Execution Status Information

Printer Status Info and Execution Status Info are defined terms and can therefore be extended or reduced by camera manufacturers. Therefore Biograph Vision shall be flexible.

If any other printer status info or execution status info is received, Biograph Vision will react as shown in the following table:

Table 204: Additional DICOM Execution Status Information

Printer Status /Execution	Printer/Execution Status Info	Description	Message string visible in the Status Bar	Other action for <i>syngo</i> /camera symbol
WARNING	<any other>	<not defined status info>	Camera info: <status info>	<None>/interact
FAILURE	<any other>	<not defined status info>	Camera info: <status info> Queue stopped.	Queue for this camera will be STOPPED/Queue stopped

Published by Siemens Healthineers ·Doc-Ident. 10753734-EKL-000· ©Siemens Healthineers AG, 2026

No part of this documentation may be reproduced or transmitted in any form by any means, electronic or mechanical, without written permission of Siemens Medical Solutions USA, Inc.

The authorized EU Representative is:
Regional Manager — Europe
Siemens Healthcare AG,
Siemensstr. 3, 91301 Forchheim,
Germany

© 2022, Siemens Medical Solutions USA,
Inc.
Printed in USA

Contact Address

Siemens Medical Solutions USA
Molecular Imaging
2501 N. Barrington Road
Hoffman Estates, IL 60192
USA
Telephone: +1-888-826-9702

Siemens Medical Solutions USA
Molecular Imaging
810 Innovation Drive
Knoxville, TN 37932
USA

Telephone: +1-888-826-9702

www.siemens-healthineers.com/dicom